

TUBE•LINE™

Tubeline Manufacturing Limited
6455 Reid Woods Drive RR #4
Elmira, Ontario, Canada N3B 2Z3

Email: sales@tubeline.ca

Fax: 519.669.5808

Tel: 519.669.9488

Toll-free (North America): 1.888.856.6613

www.tubeline.ca

Operator's Manual

Keep this manual with the machine at all times.



Bale Processor

Boss II

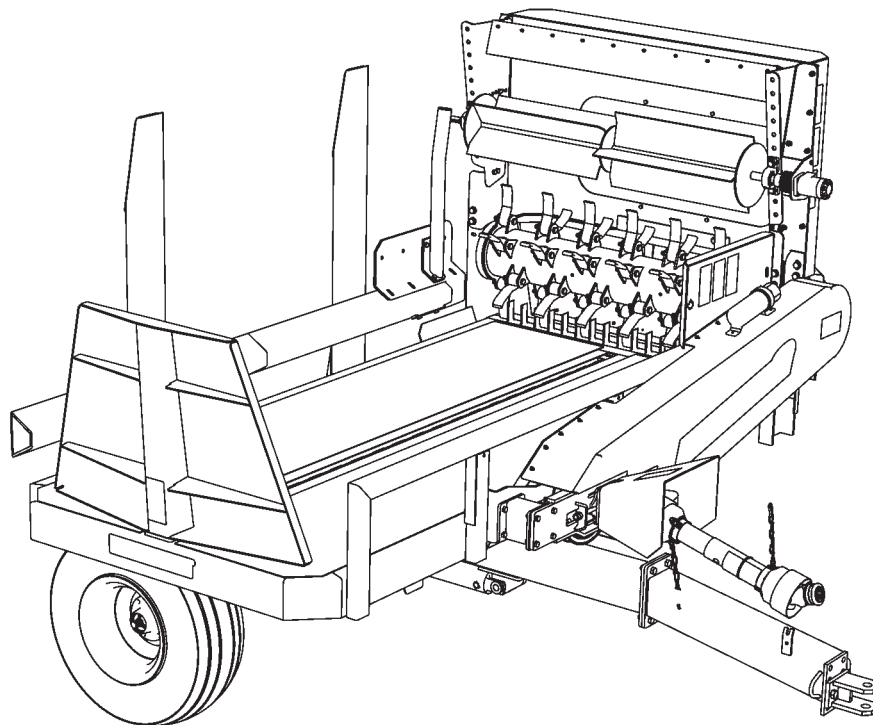

Operator's Manual

Thank you for choosing the Tubeline Boss II Bale Processor. Our hope is that it will give you many years of productive service. Please read and understand this manual and the machine before operation.

Warranty and Limitation of Liability

All equipment is sold subject to mutual agreement that it is warranted by the company to be free from defects of materials and workmanship. But the company shall not be liable for special, indirect or consequential, damages of any kind under this contract or otherwise. The company's liability shall be limited exclusively to replacing or repairing without charge, at its factory or elsewhere, at its discretion.

Any material, or workmanship defects which become apparent within one year from the date on which the equipment was purchased, and the company shall have no liability for damages of any kind. The buyer by the acceptance of the equipment will assume all liability for any damages, which may result from the use or misuse by his employees or others.

Warranty coverage is null and void unless Warranty Registration form has been completely filled in and is on file at Tubeline Manufacturing Ltd.

Serial Number Location

Always refer to the model and serial number when ordering parts or requesting information from your dealer. The serial number plate is located on left front of the tongue of your Tubeline Boss II machine.

Model No: _____ Boss II _____

Purchaser: _____

Date of Purchase: _____

Serial Number: _____

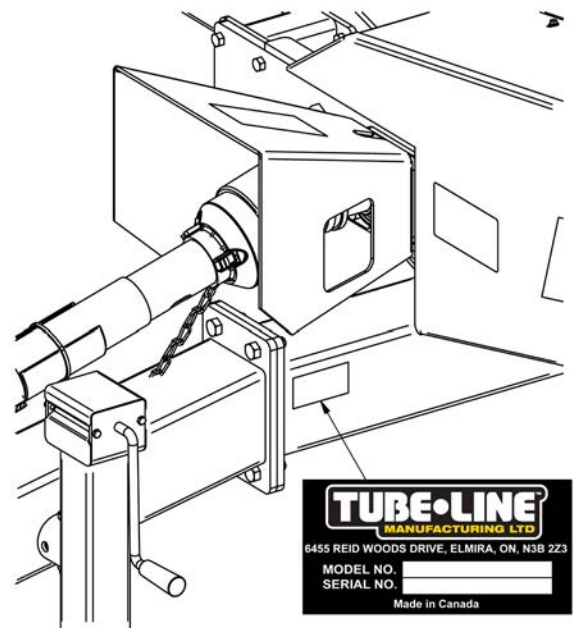

Intentionally Left Blank

Table of Contents

Operator's Manual	I
Warranty and Limitation of Liability	I
Serial Number Location	I
Section 1 - Introduction	1-1
Bale Sizes	1-1
Uses	1-1
General Information	1-1
Specifications	1-1
Minimum Hydraulic Flow Required	1-1
Maximum Flow Allowed	1-1
Power Unit Horsepower Required	1-1
Capacity	1-1
Chamber Size	1-1
Tire Size	1-1
Boss II Length	1-1
Boss II Width	1-1
Boss II Height	1-1
P.T.O.	1-1
Dual Hydraulics	1-1
Section 2 - Safety	2-1
Safety Terms and Symbols	2-1
General Safety	2-1
Maintenance Safety	2-2
Transport Safety	2-3
Hydraulic Safety	2-3
Section 3 - Safety Decal Locations	3-1
Safety Decals Placement / Replacement	3-1
Instructions	3-1
Safety Decal Illustrations	3-2
ISO Safety Decal Locations	3-3
Model Decal Illustrations	3-4
ISO Safety Decal Illustrations	3-5
Section 4 - Processor Pre-operation	4-1
Before First Use	4-1
Adjustments	4-1
Preperation	4-2
PTO Driveline	4-2
Processor Hydraulic Connection	4-3
Section 5 - Operation	5-1
Using On Inclines	5-1
Loading	5-1
Spreading Material	5-1
Section 6 - Processor Maintenance	6-1
Repairs	6-1
After Every 10 Hours of Operation	6-2
Grease Points	6-2

Section 7 - Part Breakdowns & Lists - Up to Serial Number 15B216	7-1
Tire & Axle Assembly	7-2
Bottom Beater Assembly	7-4
Upper Beater Assembly	7-6
Bale Pusher Assembly	7-8
Fork Lift Assembly	7-10
Hitch Assembly	7-11
Section 8 - Part Breakdowns & Lists - Serial Number 16B201 to Current	8-1
Hitch	8-2
Fork	8-4
Ram	8-6
Rear Idler	8-7
Front Chain Drive	8-8
Belt Drive	8-10
5/8" Flail Drum Assembly - Up to SN 22B210	8-12
1/2" Flail Drum - 50079 - SN 24B201 to Current	8-14
Upper Beater	8-16
Deflector	8-18
Hydraulic Layout	8-20
Hydraulic Flow	8-22
Section 9: Options.	9-1
Knife Kit Option.	9-1
Electric Actuator Option	9-2
Hydraulic Actuator Option.	9-3
Hydraulic Actuator Option Layout.	9-5
Section 10 - PTOs	10-1
BS208140 - 1000RPM PTO	10-1
Imperial Torque Values	V
Metric Torque Values.	VI

Section 1 - Introduction

Bale Sizes

Your Boss II Square Bale Processor is designed to load and shred all types of forage in large square bales up to 2800 pounds (1270 kg). Maximum length of bales is 102" (274cm) or 8 ½' and the width of bales may vary from 24" (61cm) to 58" (147cm).

Uses

1. Laying windrows in open fields. Drive forward slowly while feeding out bales.
2. Filling feed bunks – fence line, circular, etc.
3. Spreading forage for livestock bedding.
4. Spreading mulch over perennial plants such as strawberries and mushrooms.
5. Retractable knife section for commodity chopping.

General Information

The purpose of this manual is to assist you in safely assembling, mounting, operating and maintaining your Boss II. Read this manual carefully to obtain valuable information and instructions that will help you achieve safe and dependable service. The illustrations and data used in this manual were current at the time of printing, but due to possible engineering and/or production changes, this product may vary slightly in detail. Tubeline reserves the right to redesign and/or change components as necessary without notification.

Throughout this manual, references may be made to :

Power Unit	The engine-driven machine to which this product must be attached, ie; loader tractor, skidsteer, telehandler, etc.
Right, Left, Front, Rear	Directions which are determined in relation to the operator of the equipment when seated in the normal operating position.

Specifications

NOTE: Exceeding any of the recommended power unit specifications CAN result in damage to your power unit and/or this product and WILL void all Tubeline warranties.

Minimum Hydraulic Flow Required	20 GPM at 2500 PSI
Maximum Flow Allowed	40 GPM at 3000 PSI
Power Unit Horsepower Required	60 – 180 H.P (Higher Horse Power May Be Used w/ Caution)
Capacity	Two (2) Large square bales 2800 lb (1270 kg)
Chamber Size	52" (132 cm) high to 60" (152 cm) wide 102" (259 cm) maximum length
Tire Size	12.5L15 Tire
Boss II Length	132" (335 cm)
Boss II Width	140" (356 cm)
Boss II Height	93" (236 cm)
P.T.O.	1000 R.P.M. (540 Optional)
Dual Hydraulics	2500 PSI

Section 2 - Safety

Safety Terms and Symbols

Throughout this manual, the terms **DANGER**, **WARNING** and **CAUTION** are used to indicate the degree of hazard to personnel if proper safety procedures are not followed. These words will be used in conjunction with the Safety Alert Symbol: a dark triangle containing a white exclamation mark.



The Safety Alert Symbol means:

- ATTENTION - BECOME ALERT - YOUR SAFETY IS INVOLVED

DANGER: Indicates an imminently hazardous situation, which, if not avoided, WILL result in death or serious injury.

WARNING: Indicates a potentially hazardous situation, which, if not avoided, Could result in death or serious injury.

CAUTION: Indicates a potentially hazardous situation, which, if not avoided, May result in minor or moderate injury

NOTE: Precautions that must be followed to prevent substandard performance;
OR

May also be used to alert against unsafe practices, which may result in damage to property. The safety information given in this manual does not replace any safety codes, insurance needs, federal, state and local laws.

General Safety

Tubeline and your dealer ask that **YOU**, the owner be a careful, responsible equipment operator. **YOU** are the key to safety.

Safe operation and regular maintenance will allow this machine to serve you many years.

Familiarize all operators and maintenance personnel with the safety information and operating instructions contained within this manual. Carefully supervise inexperienced

personnel from a safe distance.

YOU, the owner, accept responsibility that non-English speaking operators/ maintenance personnel completely understand the safety precautions and machine operations enclosed in this manual.

YOU, the owner, accept responsibility for injury or death resulting from unmet safety precautions and/or unsafe operational practices.

WARNING

FAILURE TO FOLLOW INSTRUCTIONS IN THIS SECTION COULD RESULT IN DEATH OR SERIOUS INJURY.

Before attempting any type of assembly, operation, maintenance or other work on or near this product:

Read and completely understand this manual.

Read and completely understand the manuals provided with your power unit. Furthermore, read and understand all safety decals on this product and your power unit.

Know all your controls and know how to quickly stop all power unit movements, the processor movement, and the engine in case of emergency. Know and follow all applicable government rules, O.S.H.A regulations, local laws and other professional guidelines for your operation. Ensure all personnel working with/on this machine are physically and mentally capable of the safe operation of this type of equipment.

DANGER

DO NOT OPERATE OR MAINTAIN THIS MACHINE WHILE UNDER THE INFLUENCE OF DRUGS OR ALCOHOL.

Wear personal protective equipment (i.e. hardhat, safety glasses, work gloves, protective shoes, respirator, ear protection, etc.)

Never operate controls from the ground. Operate the controls only from the operator's station. Never leave the equipment unattended with the engine running.

WARNING

Do not wear loose fitting clothes, loose or uncovered hair or any accessories (jewelry, necktie, scarf, wrist watch, etc.) that can catch and entangle on moving parts.

ANNUALLY REVIEW ALL SAFETY INSTRUCTIONS.

Maintenance Safety

Work on a level surface in a well lit area. Keep the area clean and dry. Use properly grounded electrical outlets and tools. Use the right tool for the job at hand. Make sure that your tools are in good condition for performing the desired function. When using tools, wear the protective equipment specified by the tool manufacturer (i.e. hardhat, safety glasses, work gloves, protective shoes, etc.).

Before beginning any type of work on this product:

1. Apply your power unit's parking brake.
2. Stop the engine, remove the starter key.
3. Wait for all moving parts to stop.
4. Relieve all pressure in the hydraulic lines.
5. Lower processor jack to the ground and lock in place.



Refer to your power unit's operator's manual for instructions on how to relieve hydraulic pressure in lines.

See the specifications ([pg. 1-2](#)) in this manual for the weight of this product and refer to your power unit's operator's manuals for safe operating limits.

Never allow anyone, except the operator, to be around the power unit or this product when either is in motion. Do not start up unless others are clear of the work area. Do not allow riders on this product or the power unit. Do not stand or climb on this product. Do not place any part of your body under any part of this product unless this product is secured with adequate blocking.

Do not use blocking made of concrete blocks, logs, buckets, barrels or any other material that could suddenly collapse or shift positions. Do not use wood or steel blocking that shows any signs of material decay. Do not use wood blocking that is warped, twisted or tapered.

Transport Safety

- PTO must be disengaged and secured to processor prior to transporting machine.
- Be aware of the added weight and width of this product.
- Reduce travel speeds accordingly, especially when traveling over rough ground.
- Do not tow loads that weigh more than 1.5 times the weight of the tractor.
- Always keep the tractor in gear when traveling down steep grades.
- Always park the processor on level ground and block the wheels when not in use.

Hydraulic Safety

WARNING

Hydraulic fluid under pressure can penetrate the skin and cause serious injury or death. Hydraulic leaks under pressure may not be visible. Wear safety glasses, protective clothing and use a sound piece of cardboard or wood when searching for hydraulic leaks. **DO NOT USE YOUR HANDS! If any fluid penetrates the skin, SEEK IMMEDIATE MEDICAL ATTENTION!**

Section 3 - Safety Decal Locations

Safety Decals Placement / Replacement

Clean the area of application with non-flammable solvent, then, wash the same area with soap and water. Allow the surface to fully dry. Remove the backing from the safety sign, exposing the adhesive surface. Apply the safety sign to position shown in illustration below and smooth out any bubbles.

Instructions

- Keep all safety signs clean and legible.
- Replace all missing, illegible or damaged safety signs.
- Replacement parts with safety decals also require ordering replacement decals.
- Safety signs are available free of charge from your dealer or from Tube-Line.

ITEM	PART NUMBER	DESCRIPTION
1	DE23845	WARNING ! Moving Part Hazard
2	DE23847	WARNING ! High Pressure Fluid Hazard
3	DE23851	DANGER ! Injury or Death From Pinching
4	DE23848	WARNING ! Thrown Object Hazard
5	DE23837	DANGER ! Keep Hands And Feet Away
6	DE23849	DANGER ! Do Not Operate Without...
7	DE23839	WARNING ! To Prevent Serious Injury or Death
8	DE23840	CAUTION ! To Avoid Injury or Machine Damage
9	DE23850	DANGER ! Stop Engine And Remove Key
10	DE23984	WARNING ! Stay Clear While Engine Is Running
11	DE23836	WARNING ! Moving Part Hazard

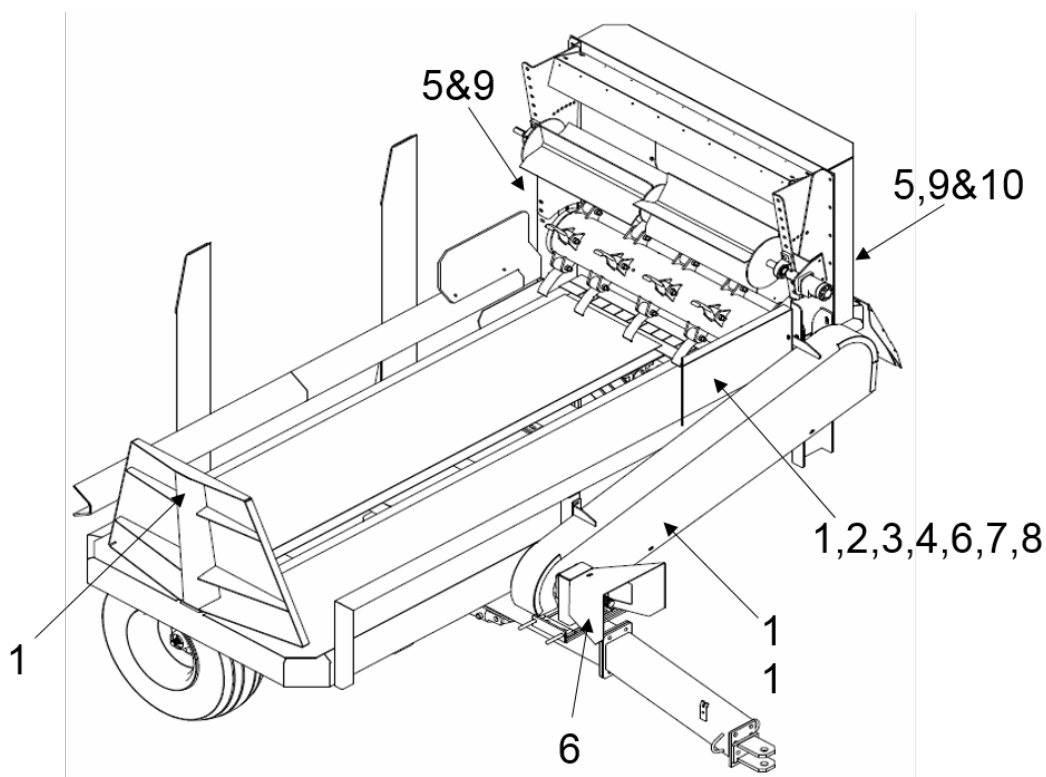

Safety Decal Illustrations

Item: 1

Part No: DE23845



Item: 2

Part No: DE23847



Item: 3

Part No: DE23851



Item: 4

Part No: DE23848



Item: 5

Part No: DE23837



Item: 6

Part No: DE23849



Item: 9

Part No: DE23850



Item: 7

Part No: DE23839

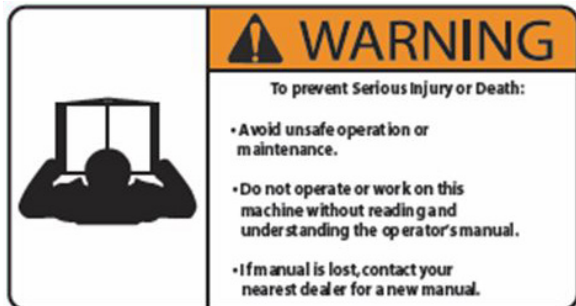

Item: 10

Part No: DE23984



Item: 8

Part No: DE23840



Item: 11

Part No: DE23836

ISO Safety Decal Locations

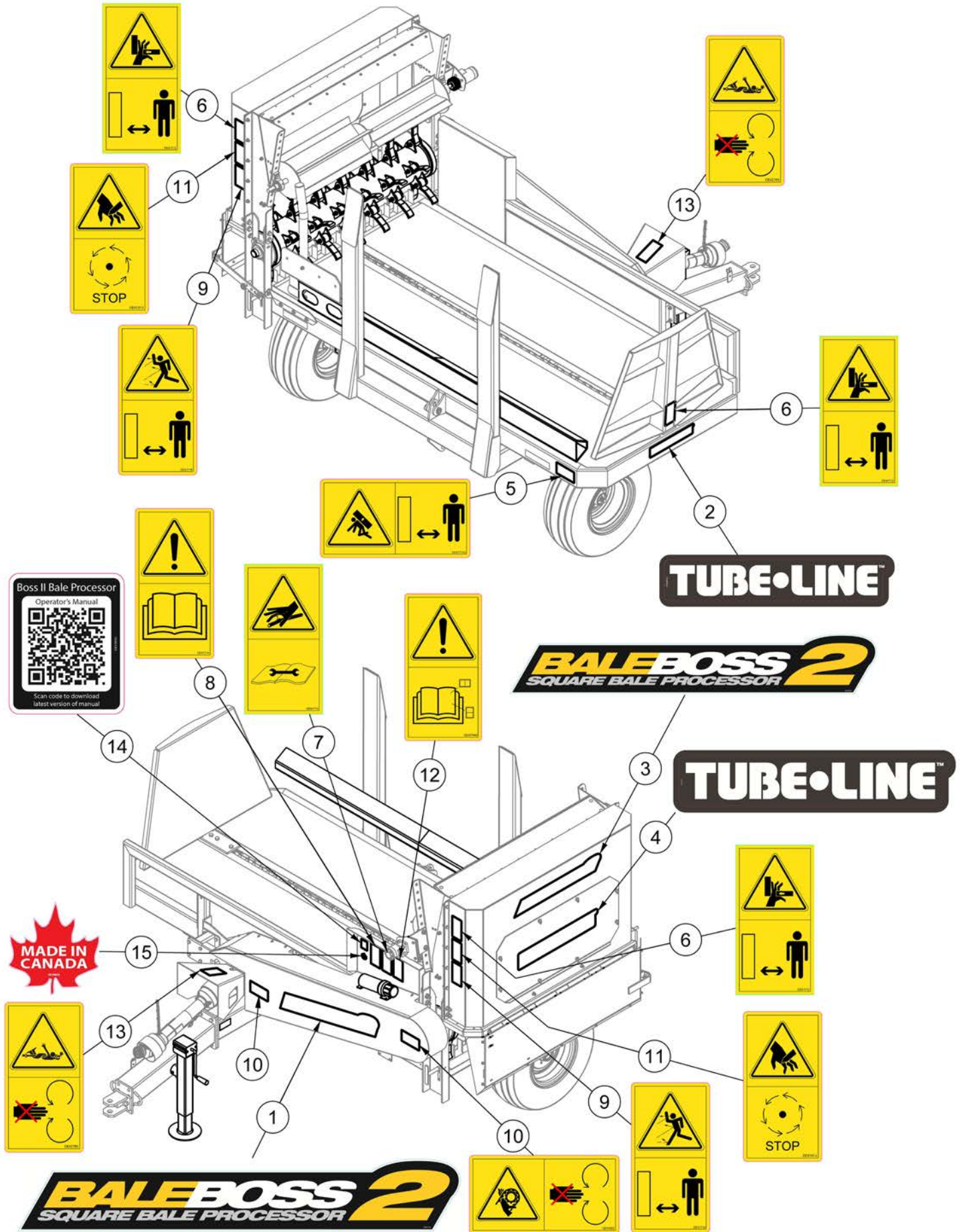

ITEM	QTY	PART NUMBER	DESCRIPTION
1	1	DE27275	BossII Processor Decal - 6 x 39.0
2	1	DE28146	Tubeline Decal 4" x 16"
3	1	DE28722	Bale Processor BossII - 4 x 32 Decal
4	1	DE30837	Tubeline Decal 7.25" x 30"
5	1	DE41711H	ISO Decal - Angled Crush Horizontal
6	3	DE41712	ISO Decal - Hand Pinch Point
7	1	DE41713	ISO Decal - High Pressure Fluid
8	1	DE41714	ISO Decal - Read Operator's Manual
9	2	DE41718	ISO Decal - Thrown Object Vertical
10	2	DE41902	ISO Decal - Chain Entanglement
11	2	DE41913	ISO Decal - Cutting Hazard
12	1	DE42784	ISO Decal - Read OM Decals Section
13	1	DE42785	ISO Decal - PTO Entanglement
14	1	DE50045	Boss II QR Decal
15	1	DECANADA	Decal Made In Canada

Model Decal Illustrations

Part No: DE27275 Item: 1

Large Boss II model decal.



Part No: DE28146 Item: 2

Large Tubeline Mfg. Ltd. decal.



Part No: DE28722 Item: 3

Small Boss II model decal.



Part No: DE30837 Item: 4

Small Tubeline Mfg. Ltd. decal.



ISO Safety Decal Illustrations

Part No: DE41711H Item: 5

Crush hazard from bale loading arm. Stand clear while arm raised.



Part No: DE41712 Item: 6

Pinch point hazard from bale loading arm. Stand clear while arm in motion.



Part No: DE41713 Item: 7

High pressure fluid hazard. Refer to Maintenance notes on [pg.2-2](#).



Part No: DE41714 Item: 8

Read this manual and learn the machine functions before attempting to wrap bales.

Part No: DE41718

Item: 9

Thrown object hazard. Stand clear of feed path.



Part No: DE41902 Item: 10

Keep hands clear of rotating parts while machine running. Do not operate without shielding in place. Do not wear loose clothing while operating.





**Part No: DE41913
Item: 11**

Sharp knives can cause dismemberment. Wait for moving parts to stop before attempting to repair.



Part No: DE42784 Item: 12

Read the decal section of the operator's manual to understand potential hazards to avoid.



**Part No: DE42785
Item: 13**

Stand clear of PTO drivelines while operating. Entanglement could cause paralysis or death.



Part No: DE50045 Item: 14

QR Code Decal, scan with smartphone to access machine's manual online.



Part No: DECANADA Item: 15

Manufacturer of origin decal.

Section 4 - Processor Pre-operation

Safety first! Read and understand the safety instructions (pg.2-1) before operating.

Before First Use

- Inspect the attachment for shipping damage. If damage does exist, do not operate until the damaged parts have been replaced or repaired. Replace any damaged parts before operating, call dealer for Warranty information and/or claims.
- Check air pressure in tires – 35lb. (15.9 kg).

Adjustments

- Machine is assembled complete from the factory less hitch mountings.
- Processor hitch can be moved up or down to suite power unit drawbar. Remove bolts and nuts from hitch, raise or lower hitch to desired position and refasten hardware. Deck of processor should sit level for best operation. Improper hitch adjustments may cause separation from the PTO drive-line when operating on uneven terrain.
- Conveyor chain should be adjusted to allow chain slack 1” (2.54 cm) to 1 1/2” (3.8 cm).
- Deflector shield angle can be adjusted by removing lock pin and moving bar to different hole and/or different pin.
- Check air pressure in tires – 35lb. (15.9 kg)
- If machine is equipped with optional knife kit, it can be lowered or raised to suite your operation and/or feed material.
- Flow controls on front of processor adjust the ram (right side) and top beater (left side). Moving lever left decreases flow to slow that function, right increases flow - speed up function. Twist knob to tighten or loosen lever position.

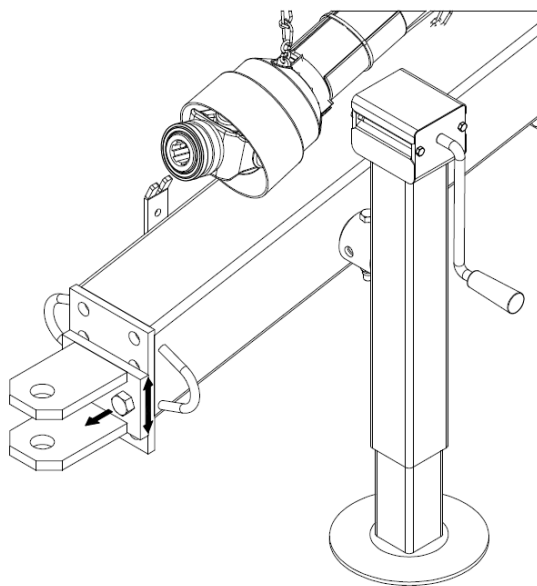

Top Beater
Flow Control



Ram Flow Control



Preperation

- Check chains and belts for proper tension.
- Make certain that all safety signs are in place and legible. Refer to the safety sign page in this manual for the placement of safety signs for this product.
- Remove any twine / netting from flail drum with a utility knife. Twine build up can cause drum imbalance.
- Make certain that all locking pins, latches and connection devices are properly installed and secured.
- Remove fork transport lock pin. Store on power unit.
- Remove all foreign objects from processor and bales.
- Back power unit to Boss II hitch.
- Attach Boss II Processor to power unit by dropping drawpin through holes in processor hitch and power unit drawbar.
- Turn handle on jack until it is fully raised.
- Pull pin out of jack bushing, pivot horizontally, lock pin in place.
- Remove blocking from wheels before moving processor.
- Drive slowly through gates and doors.
- **DANGER:** Avoid contacting overhead wires.

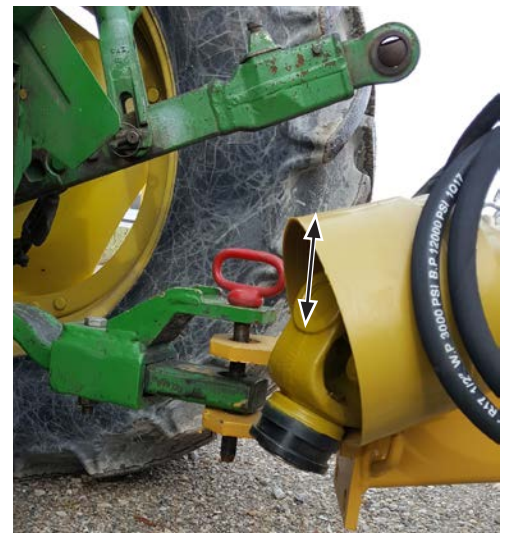
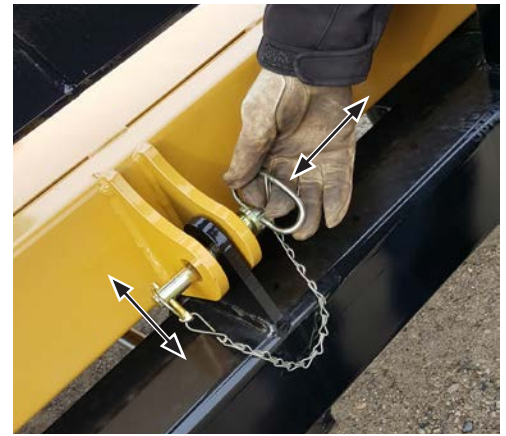

PTO Driveline

The PTO driveline drives the Flail Drum.

- Inspect driveline shield for free rotation.
- Only connect processor PTO drivelines to corresponding PTO power unit drive shafts, 1000 RPM to 1000 RPM or 540 RPM to 540 RPM. Do not attempt to use a miss matched PTO connection.
- PTO drive-line maintenance instructions must be read before attaching and operating. The maintenance instructions are attached to the chain supplied on the drive-line. **Failure to do so may result in damage to the drive-line and/or machine, may also void warranty.**
- Proper and adequate length of the drive-line must be maintained in order to have maximum one third engagement of telescoping tubing.
- Too short of a drive-line will result in premature failing of the drive-line. Too long of a drive-line will result in damage to drive-line, tractor PTO and implement.
- PTO shaft drive-line must not be opened without all safety shields in place. PTO shaft drive-line must be attached securely before operating.
- At no time should any persons be in the immediate area of the PTO shaft drive-line and machine while the PTO shaft drive-line is being operated.

DANGER: Tractor PTO must be disengaged and tractor shut off before approaching or contacting the PTO shaft drive-line.

- Connect processor PTO driveline to power unit PTO stub shaft.

Processor Hydraulic Connection

Safety first! Read and understand the safety instructions (pg.2-3) before beginning any hydraulic connection.

The Boss II processor's hydraulic system requires dual outlets on the tractor.

The machine's hydraulic system performs two functions. One function tilts the fork for loading bales to top of the machine. The second function powers the bale pusher by means of a hydraulic motor. Desired speed of the pusher is controlled by a flow control valve located on the front of the machine. See [Adjustment](#) section.

- Before connecting or disconnecting hydraulic hoses, read your tractor or power unit's operator's manual for detailed instructions on connecting and disconnecting hydraulic attachments.
- Before applying pressure to the system, be sure that all connections are tight and be sure there are no damaged hoses, lines or fittings.
- Make certain that the hoses cannot interfere with or actuate the quick-attach mechanism. Make certain that hoses will not be pinched, or get tangled, in any equipment.
- Check for cylinder wear and broken flails and flail bracket wear.
- Remove quick coupler caps and clean quick coupler ends before connecting to power unit.
- Do not lock the auxiliary hydraulics of your power unit in the "ON" position.
- Attach hydraulic hose quick couplers to your power unit as per the instructions in your power unit's operator's manual.
- After connecting hydraulic lines, operate the hydraulics on this product to check hose clearances and to check for any interference.
- Shut off engine, set parking brake and relieve hydraulic pressure before connecting or disconnecting hydraulic lines. Refer to your power unit's manual for instruction on how to relieve hydraulic pressure in lines.



Section 5 - Operation



WARNING! Remove twine buildup from flail drum before starting machine.

Using On Inclines

When working on inclines or slopes, travel uphill or downhill. Be sure to keep tractor transmission in gear when traveling downhill.

Loading

- Load one bale at a time. If bales are frozen, put frozen side down to the table for better operation.
- Center the bale on the forks before loading on to the table.
- Slide forks lightly on the ground when loading bales.
- Always set the parking brake, stop the engine, remove ignition key, and wait for all moving parts to stop before leaving the operator's seat.



Spreading Material

- Start flail drum by engaging PTO from power unit. Operating power unit at maximum R.P.M. allows the processor to do a better job of chopping forage.
- To spread material, use power unit hydraulic control to move the ram towards the flail drum.
- Once material has been completely discharged from processor, reverse the ram with power unit hydraulic control before loading next bale.
- If ram is feeding too slow or flail drum is clogging up, adjust flow controls on front of processor to desired feed rate. See [Adjustment](#) section.
- Decreasing the speed of the pusher allows optional flail knives to chop forage finer, increasing the speed leaves forage coarser when the knives are in the upward position.



Section 6 - Processor Maintenance

Regular maintenance is the key to long equipment life and safe operation. It is very important that these maintenance functions be performed as described below.



Safety first! Read and understand the safety instructions (pg.2-1) before beginning any processor maintenance operation.

Repairs

- Wear safety glasses and use metal or wood when searching for leaks. Do not use your hands.
- Securely support any machine elements that must be raised for service work.
- Lower fork to the ground.
- When making repairs, use only genuine Tubeline parts or, for fasteners, hydraulic hoses or hydraulic fittings, use only properly rated parts.
- Replace broken flails and remove any twine buildup to keep the flail drum in balance.
- Clean any buildup of grease, oil, or debris.
- PTO shear bolt replacement must be done only with shear bolts of the same grade and diameter supplied on the drive-line.
- When lubricating drive-line telescoping shafts, it is imperative that yokes remain phased. In order to maintain phasing, the flat profile of the inner tube must be engaged with the flat profile of the outer tube. Failure to do so will result in damage to cross and bearings and premature shearing of the shear bolt.
- Steam-clean the power unit before any installation is made to the hydraulic system.
- Make certain that all parts meet the specifications for this product when installing or replacing hydraulic hoses or fittings.

Think SAFETY! Work SAFELY!

IMPORTANT

The flail tube on this machine is a fully balanced assembly. If for any reason the flails must be removed, they must be returned to the same position they were taken from. If this is not done a balance problem will result in causing machine vibration. Number flails and inserts and their positions before you do any work.

After Every 10 Hours of Operation

Grease all bearings. Inspect and tighten Allen screws on bearing.

Grease Points

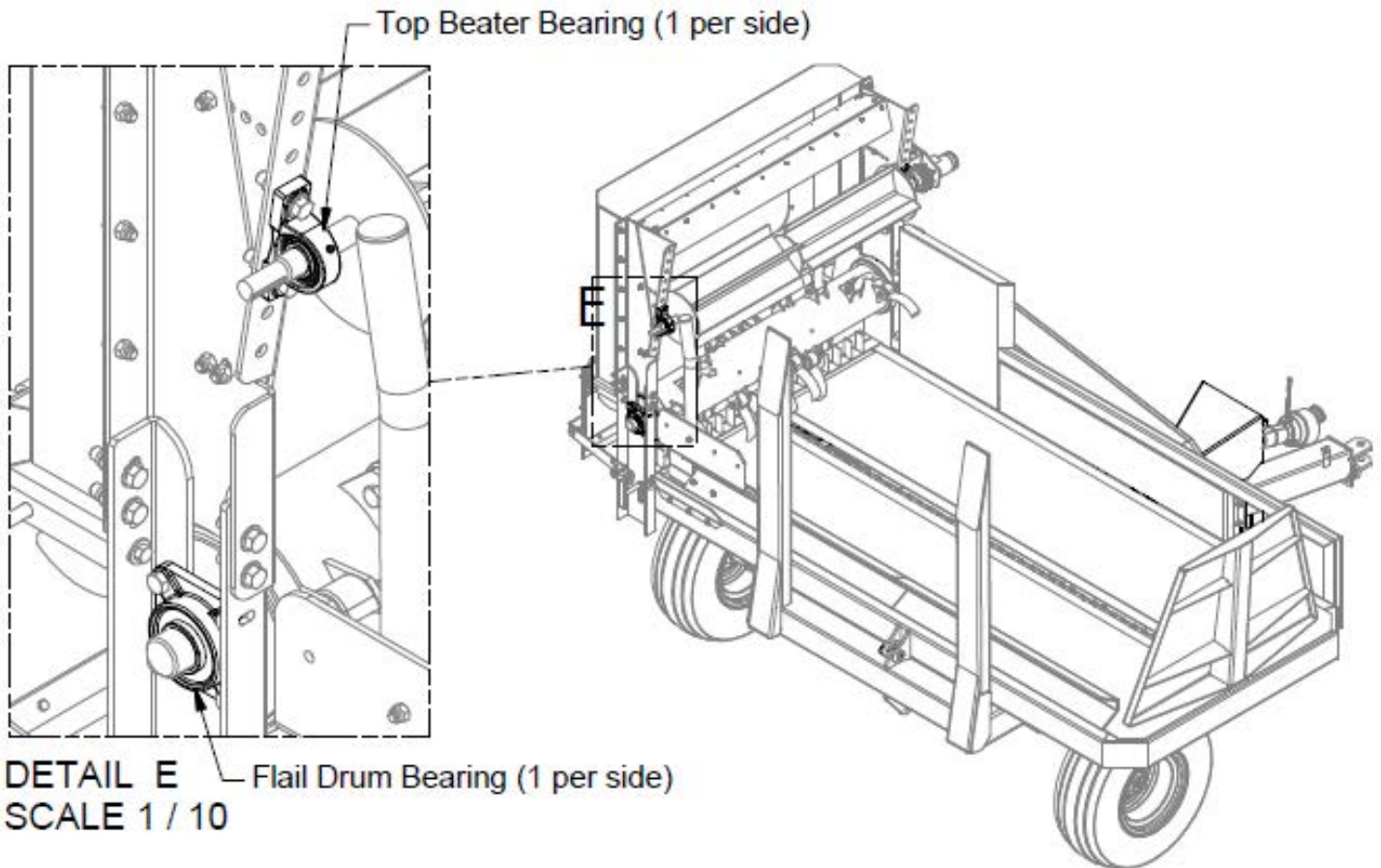

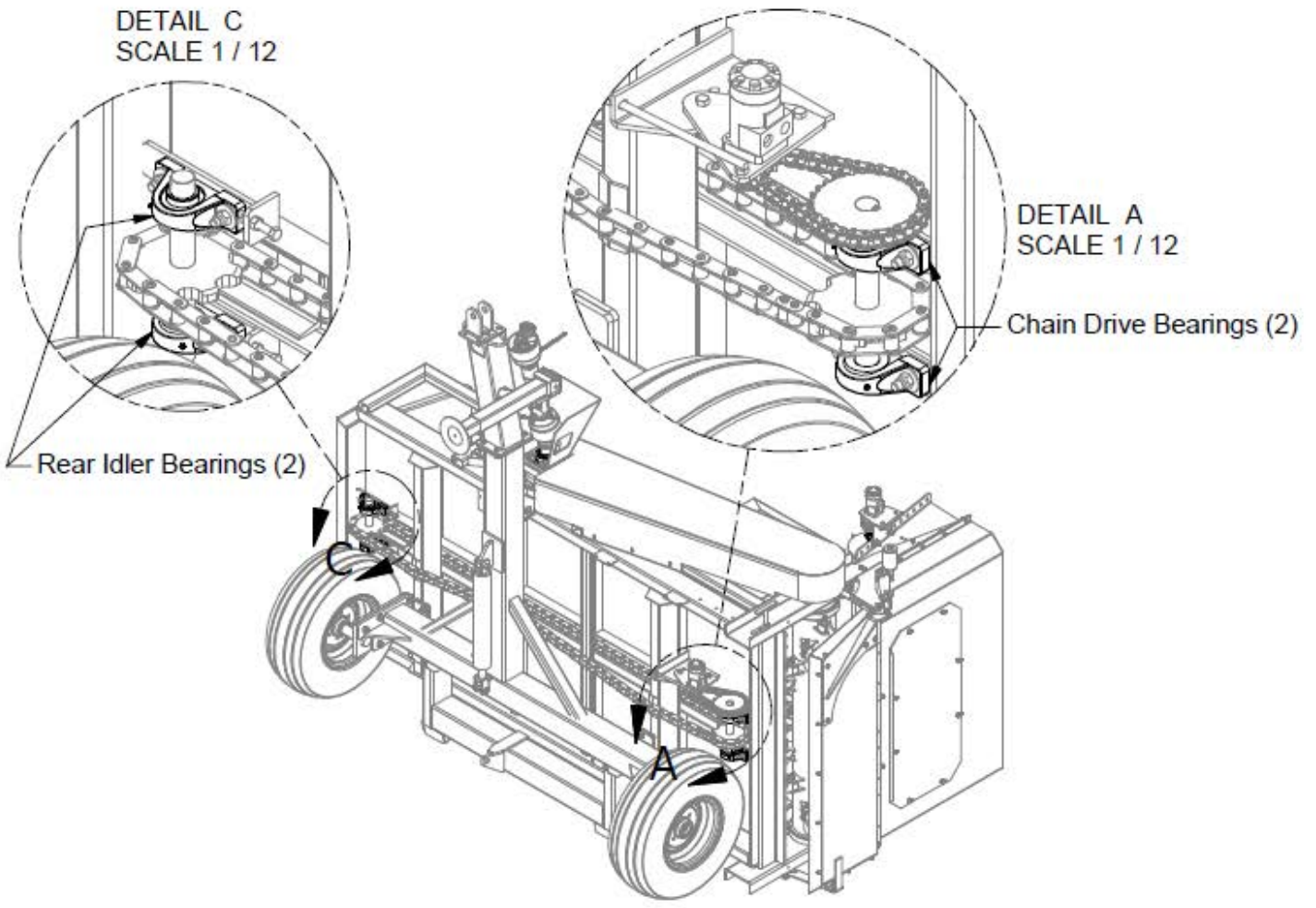
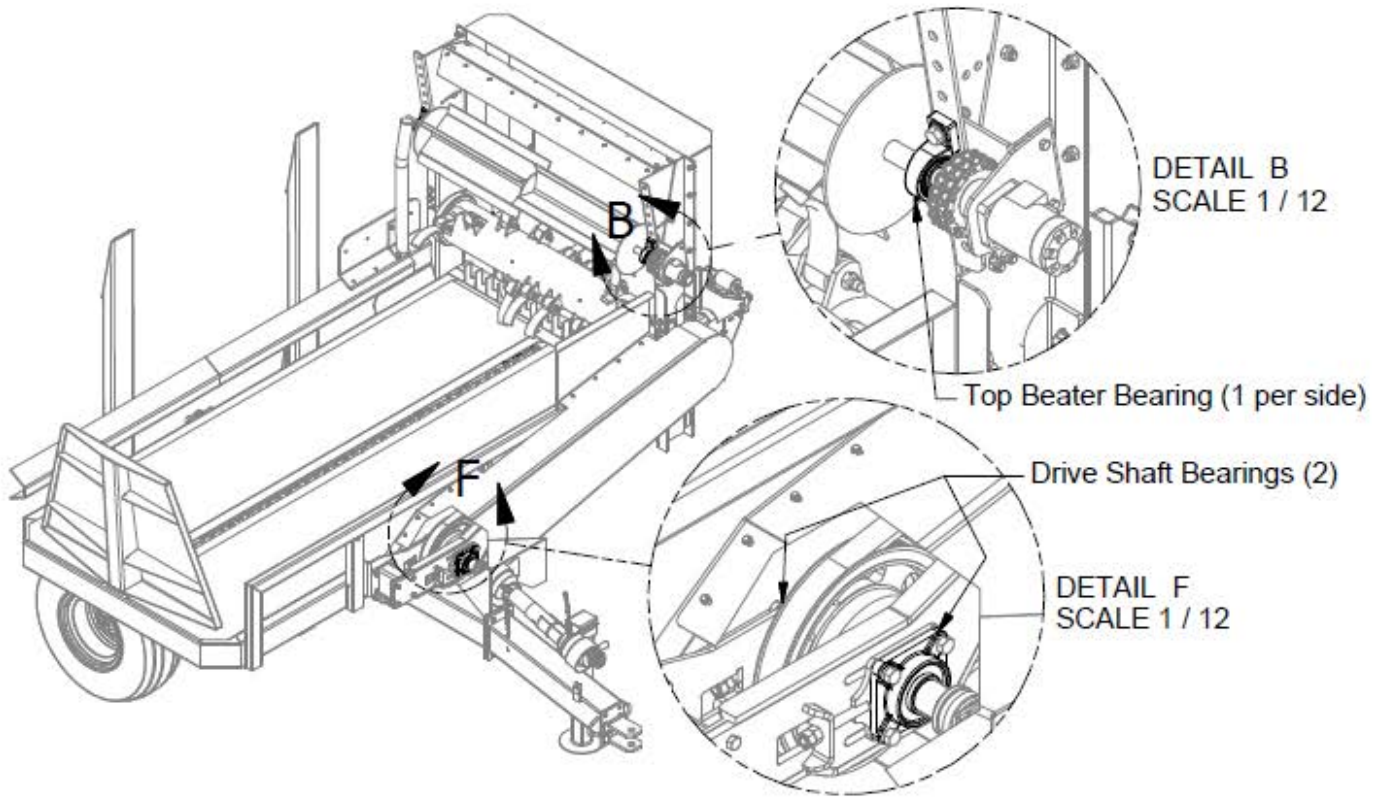

Intentionally Left Blank

Section 7 - Part Breakdowns & Lists - Up to Serial Number 15B216

Tire & Axle Assembly

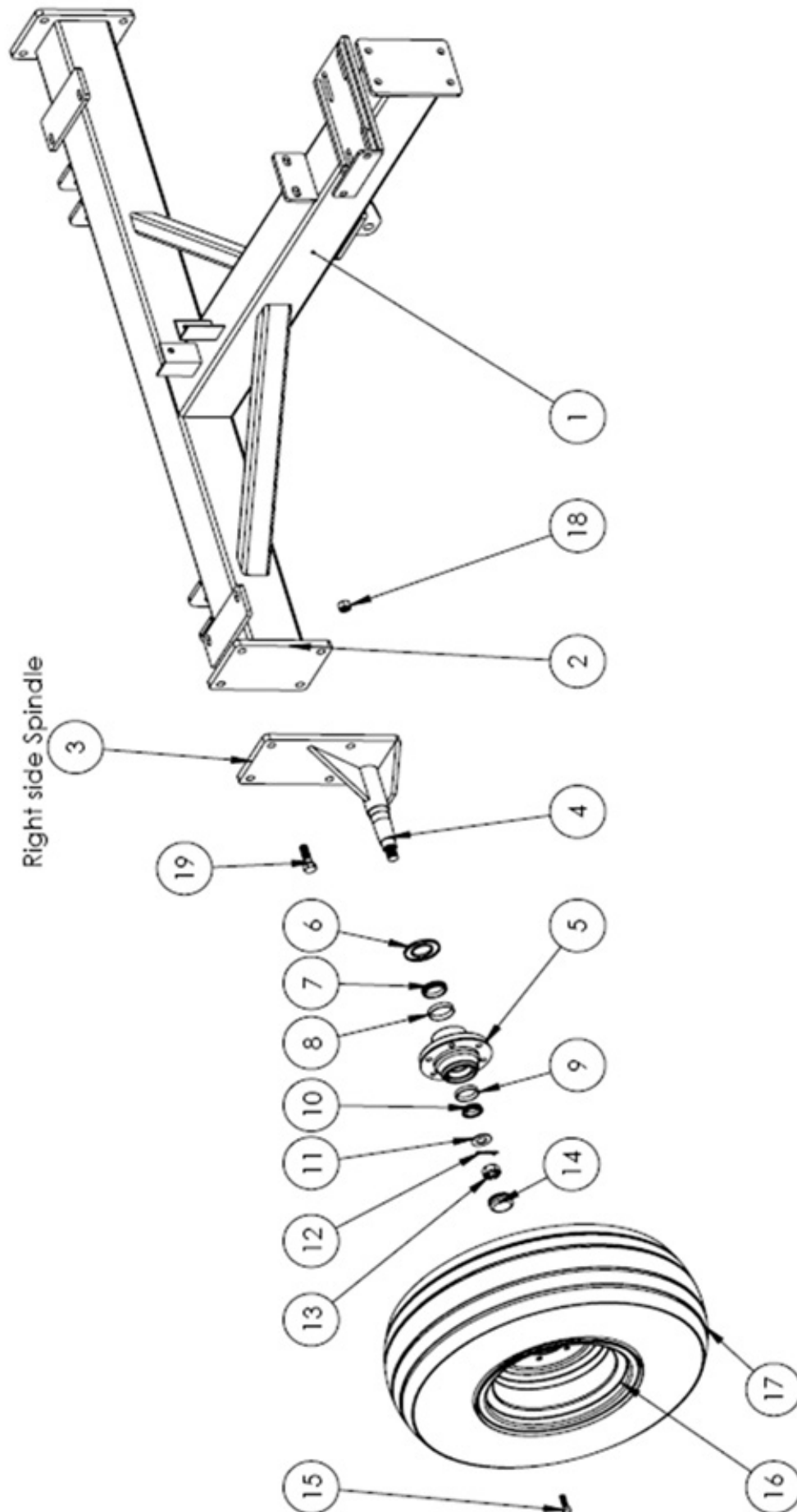

Tire & Axle Assembly

ITEM	QTY	PART NUMBER	DESCRIPTION
1	1	200092A	Main Hitch Axle Tube
2	2	200095A	Bolt-on Spindle Plate
3	1	208120	Right Spindle Weld Assembly
	1	208121	Left Spindle Weld Assembly
4		208122	Straight Spindle (2 1/4 x 12 3/4)
5		208126	Hub (W-6000)
5A	2	208127	Hub c/w Parts (W-6000) (Ref # 6-15)
6		208123	Seal
7	2	208124	Inner Bearing
8	2	208125	Inner Cup
9	2	208128	Outer Cup
10	2	208129	Outer Bearing
11	2	208130	1" Washer
12	2	208131	Cotter Pin
13	2	208132	1" Slotted Hex Nut (1-14)
14	2	208133	Dust Cap
15	12	208134	Wheel Bolt (9/16 x 1 3/4)
16	2	208135	15 x 8 x 6 Rim
17	2	208136	12.5L – 15 x 6 Ply Tire
18	8	LN 3/4	Locknut
19	8	HB 3/4 x 2 1/2	Hex Bolt

Bottom Beater Assembly

ITEM	QTY	PART NUMBER	DESCRIPTION
1	1	BS208140	PTO Complete
2	1	39492	PTO Stub Shaft
3	4	BS199399A	Square Bearing, 2" Bore c/w zerk
4	1	BS200150A	PTO Shield
5	2	BS208141	Bearing Protector
6	1	BS208142	Bottom Beater
7	20	BS20060A	Flail
8	1	BS200177B	Outer Lid Support Angle
9	1	BS208143	Front Bottom Beater Lid
10	20	BS200059A	Flail Bushing
11	1	BS200069A	2" Shaft, Flail Tube
12	1	BS208144	Belt Shield
13	1	BS208102	Pulley Sprocket 80T
14	2	BS208103	Taper Lock Hub c/w setscrews
15	1	BS208104	Pulley Sprocket 60T
16	1	BS200165A	Drive Belt
17	1	BS200106A	Pulley Adjusting Bracket
18	1	BS208105	Side Discharge Adjuster
19	1	BS208106	Side Discharge Deflector
20	1	BS200100A	Deck Main Frame
21	20	BS208150	5/8-18 NFT x 4 Gr.8 Bolt
22	20	BS208151	5/8-18 NFT Steel Locknut

Upper Beater Assembly

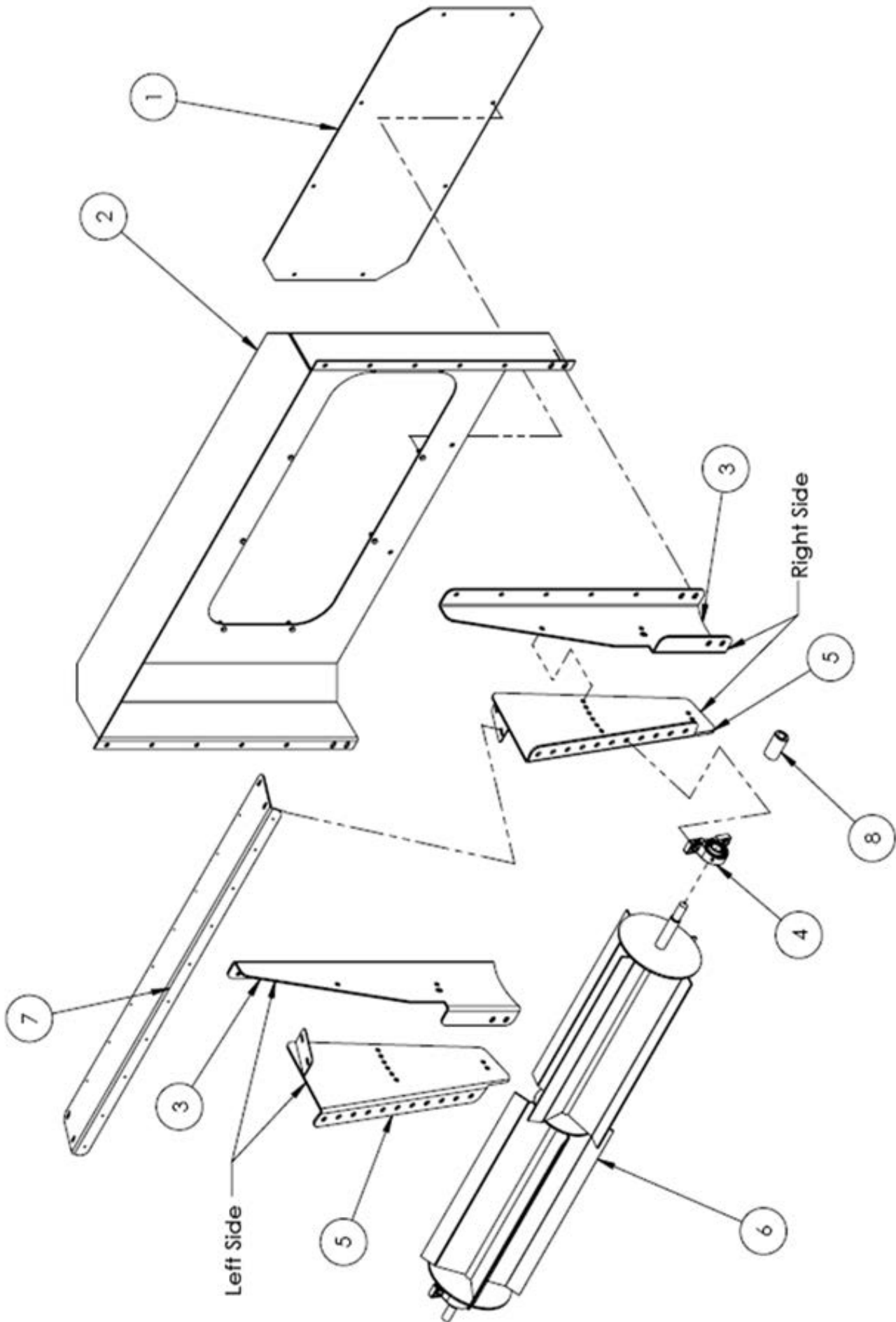

Upper Beater Assembly

ITEM	QTY	PART NUMBER	DESCRIPTION
1	1	200174B	Upper Lid Front Plate
2	1	200170D	Front Shield
3	2	200172C	Outer Side Plate, Right & Left
4	2	208137	1 1/4 Pillow Block Bearing
5	2	208138	Inner Side Plate, Left & Right
6	1	208139	Upper Beater
7	1	200175B	Top Plate Roof Cover
8	1	208115A	Top Beater Motor Coupler

NOTE: Item 8 must be replaced with chain sprocket. Refer to [pg.8-14](#), Items 20 and 21.

Bale Pusher Assembly

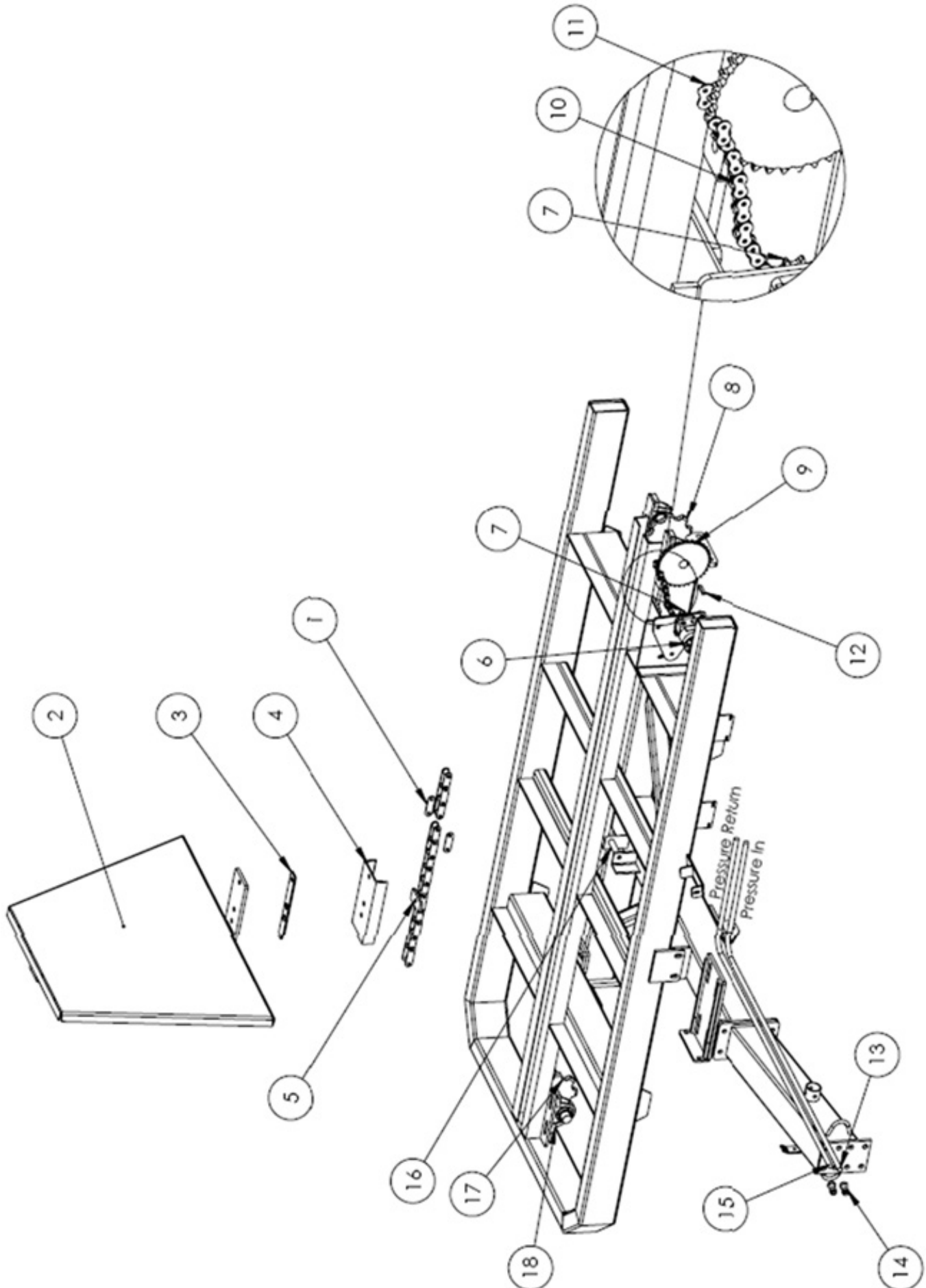

Bale Pusher Assembly

ITEM	QTY	PART NUMBER	DESCRIPTION
1	1	BS199199A	Connector Link
2	1	BS200003A	Bale Pusher
3	1	BS200001A	Bale Pusher Guide Plate
4	1	BS200000A	Bale Pusher Mount Channel
5	1	BS200145A	Conveyor Chain
6	1	BS208107A	1006 Hydraulic Motor
7	1	BS198998A	Sprocket 60B11
8	1	BS200141A	Drive Sprocket 8T
9	1	BS208108A	Sprocket 60B36
10	1	BS208109A	Roller Chain #60H x 37 3/8
11	1	BS208110A	Connector Link #60H
12	1	BS200143A	3/8 x 2 Keystock
13	1	BS-01	Pressure In Hydraulic Hose
14	2	HF-8010-4	Pioneer Ends 1/2 FPT
15	1	BS-04	Pressure Out Hydraulic Hose
16	1	BS200009A	Conveyor Chain Bushing
17	1	BS200138A	Idler Sprocket 8T
18	4	BS199398A	Pillow Block Bearing 1.5 Bore

Fork Lift Assembly

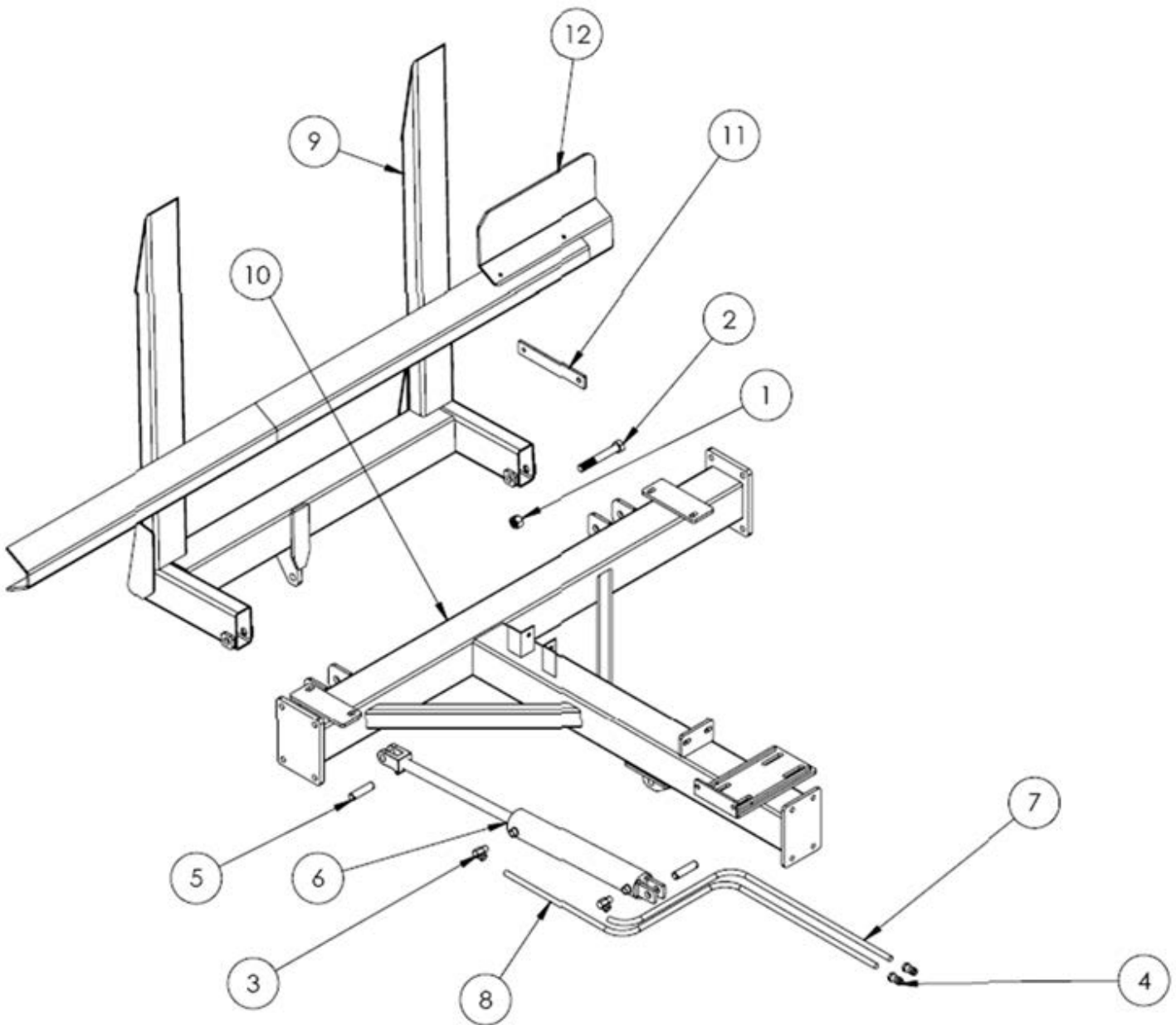

ITEM	QTY	PART NUMBER	DESCRIPTION
1	2	LN 1	Locknut
2	2	HB 1 X 7	Hex Bolt
3	2	HF 1501-8-8	Elbow Swivel 90* .5 MPT x .5 FPT
4	2	HF 8010-4	Pioneer Ends .5 FPT
5	2	BS199799A	1" Cylinder Pin
6	1	BS199899A	Forklift Cylinder
7	1	BS-09	Cylinder Blank End Hydraulic Hose
8	1	BS-10	Cylinder Rod End Hydraulic Hose
9	1	BS208145	Fork Lift
10	1	BS200091A	Main Hitch
11	1	BS208112	Fork Lift Lock Strap
12	1	BS208146	De-dribbler

Hitch Assembly

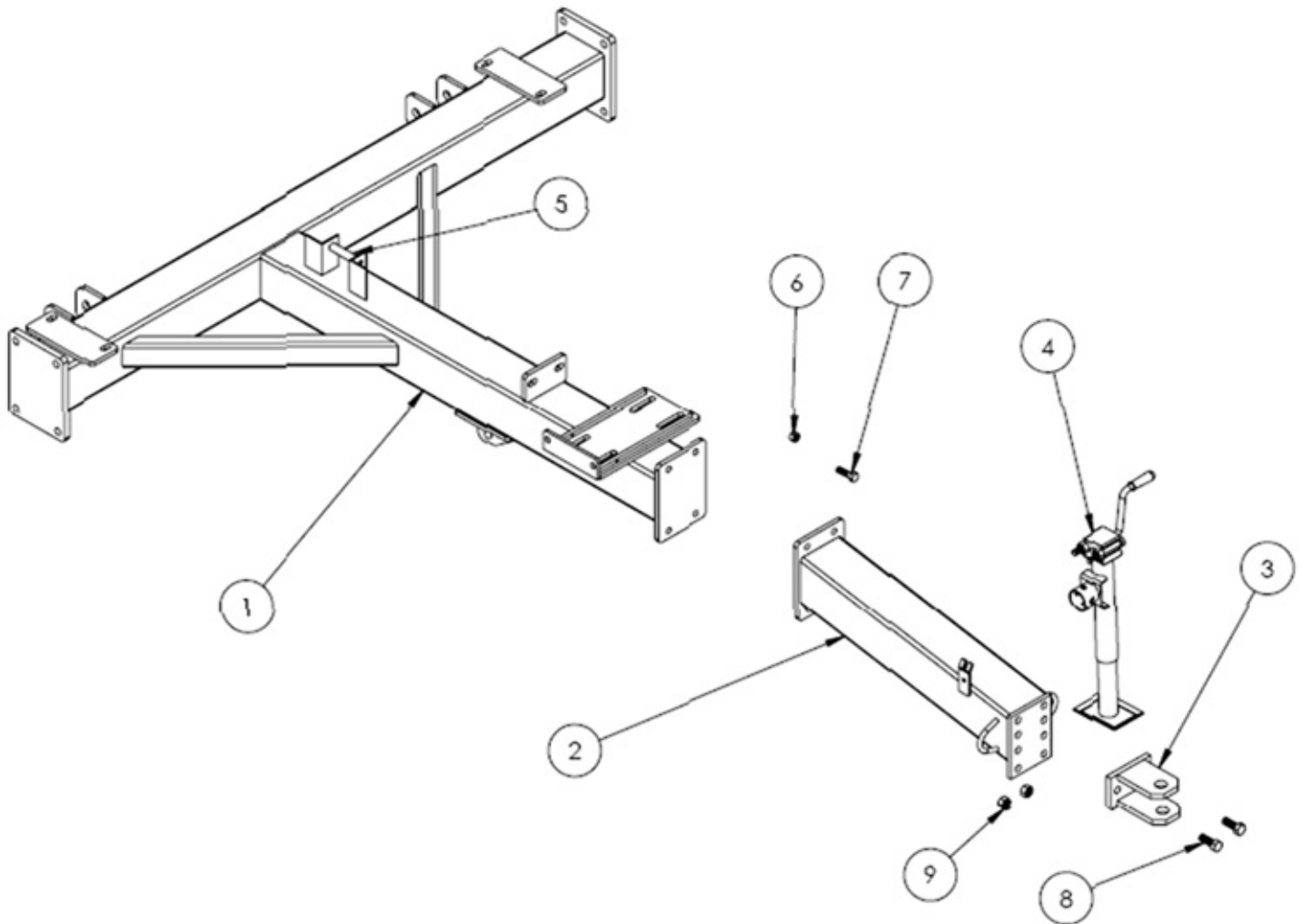

ITEM	QTY	PART NUMBER	DESCRIPTION
1	1	BS200091A	Main Hitch
2	1	BS208147	Bolt-on Hitch Tube
3	1	BS208148	Bolt-on Tongue
4	1	25719	Jack
5	1	BS200185A	Chain Idler
6	4	LN 5/8	Locknut
7	4	HB 5/8 x 2	Hex Bolt
8	2	HB 3/4 x 2	Hex Bolt
9	2	LN 3/4	Locknut

Intentionally Left Blank

Section 8 - Part Breakdowns & Lists - Serial Number 16B201 to Current

Hitch

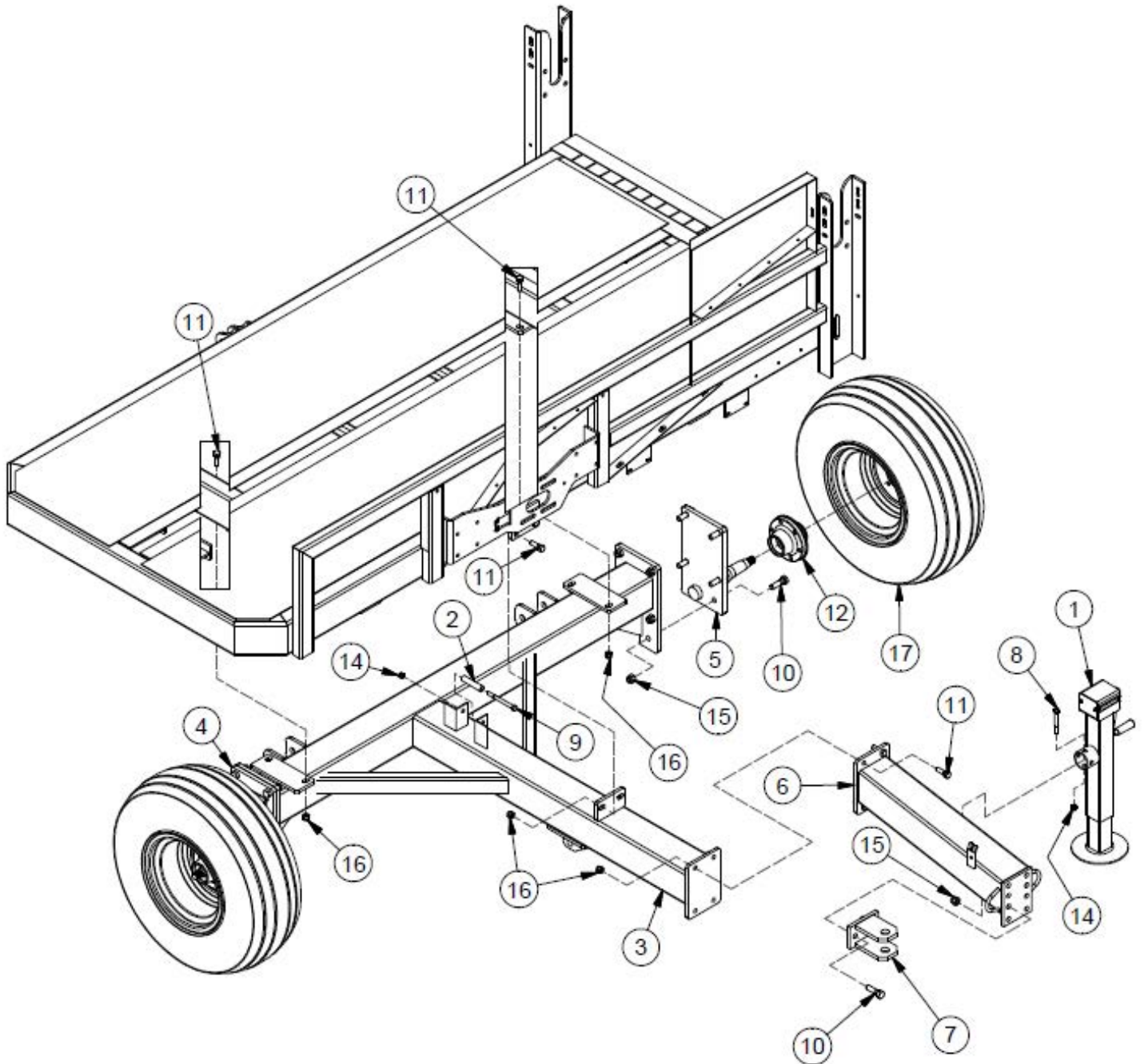

Hitch

ITEM	QTY	PART NUMBER	DESCRIPTION
1	1	25719	Jack, Heavy Duty for TB980
2	1	BS SAW200040	Tee Handle/Chain Roller
3	1	BS200091	Main Hitch
4	1	BS208120	Spindle Weldment RH
5	1	BS208121	Spindle Weldment LH
6	1	BS208147	Tongue Weldment
7	1	BS208148	Bolt on Hitch for Boss II
8	1	HB 1/2-13X4.0 Z5	Hex Bolt 1/2-13 x 4 Grade 5 Zinc Hex Cap Screw
9	1	HB 1/2-13X6.0 Z5	Hex Bolt - 1/2"-13 x 6" Grade 5 Zinc Plated Hex Cap Screw
10	12	HB 3/4-10X2.1/2 Z5	Hex Bolt - 3/4-10 x 2 1/2" Grade 5 Zinc Plated Hex Cap Screw NC
11	22	HB 5/8-11X2.0 Z5	Hex Bolt 5/8-11 x 2 Grade 5 Zinc Plated Hex Cap Screw NC
12	2	HUB 6000#	Boss, Technobale, Bale Feeder Hub
13	1	HUB 6000-CCS	Complete Bearing and Seals for Hub 6000
14	40	LN 1/2 N	Locknuts - 1/2-13 Zinc Plated Nylon Insert Lock Nut
15	12	LN 3/4 N	Locknuts - 3/4-10 Zinc Plated Nylon Insert
16	27	LN 5/8 N	Locknut - 5/8-11 Zinc Plated Nylon Insert Lock Nut
17	2	WHE 12X15X 10	12 x 15 10 Ply Good Year on 15x10x6 rim

Fork

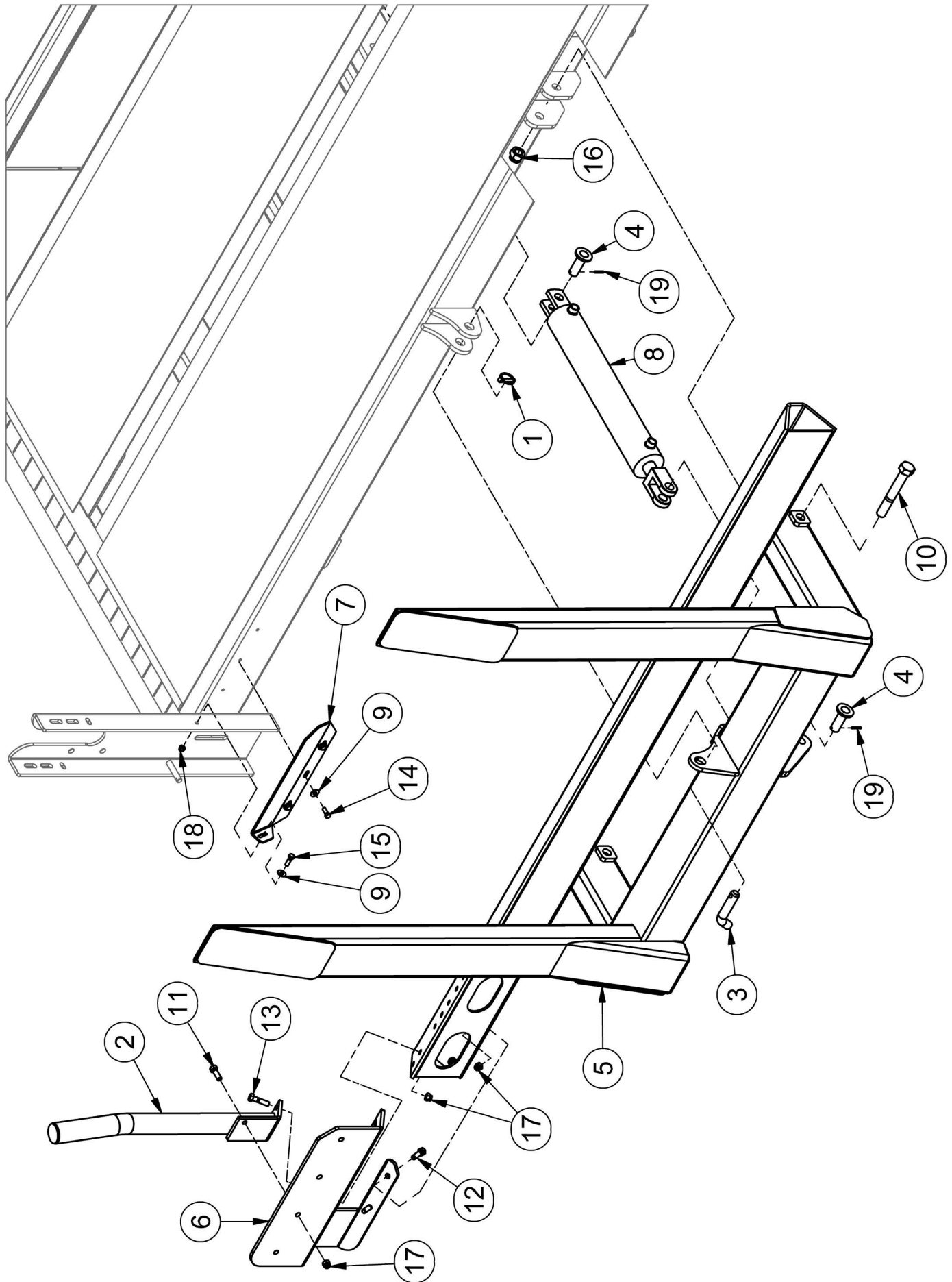

Fork

ITEM	QTY	PART NUMBER	DESCRIPTION
1	1	28940	Lynch Pin - 3/8 x 1-3/4"
2	1	33307	Bale Stop Weldment
3	1	36669	Transport Lock Pin
4	2	39010	Cylinder Pin (Weldment)
5	1	37541	Forklift Assy for BossII
6	1	BS PCT200000	Dribbler
7	1	BS PCT200180	Fork Protector Plate
8	1	BS199899A	Cylinder, Boss II Fork (Lift) - 3-1/2" X 20-1/2"
9	4	FW 3/8	Flatwasher - 3/8" Zinc Plated USS
10	2	HB1-8X7Z5	Hex Bolt 1-8x7 Grade 5 Zinc Plated Hex Cap Screw
11	1	HB1/2-13X1.5Z5	Hex Bolt 1/2-13x1 1/2 Grade 5 Zinc Plated Hex Cap Screw
12	2	HB1/2-13X1.75Z5	Hex Bolt 1/2-13x1 3/4 Grade 5 Zinc Plated Hex Cap Screw
13	1	HB1/2-13X2Z5	Hex Bolt 1/2-13x2 Grade 5 Zinc Plated Hex Cap Screw
14	3	HB3/8-16X1Z5	Hex Bolt 3/8-16x1 Grade 5 Zinc Plated Hex Cap Screw
15	4	HB3/8-16X1.25Z5	Hex Bolt 3/8-16x1 1/4 Grade 5 Zinc Plated Hex Cap Screw
16	2	LN1-8NCZ5	LN 1-8 Zinc Plated Nylon Insert Lock Nut
17	4	LN1/2-13NCZ5	LN 1/2-13 Zinc Plated Nylon Insert Lock Nut
18	1	LN3/8-16NCZ5	LN 3/8-16 Zinc Plated Nylon Insert Lock Nut
19	2	RP 3/16 x 1 1/4	Pin - Roll Pin 3/16 x 1 1/4

Ram

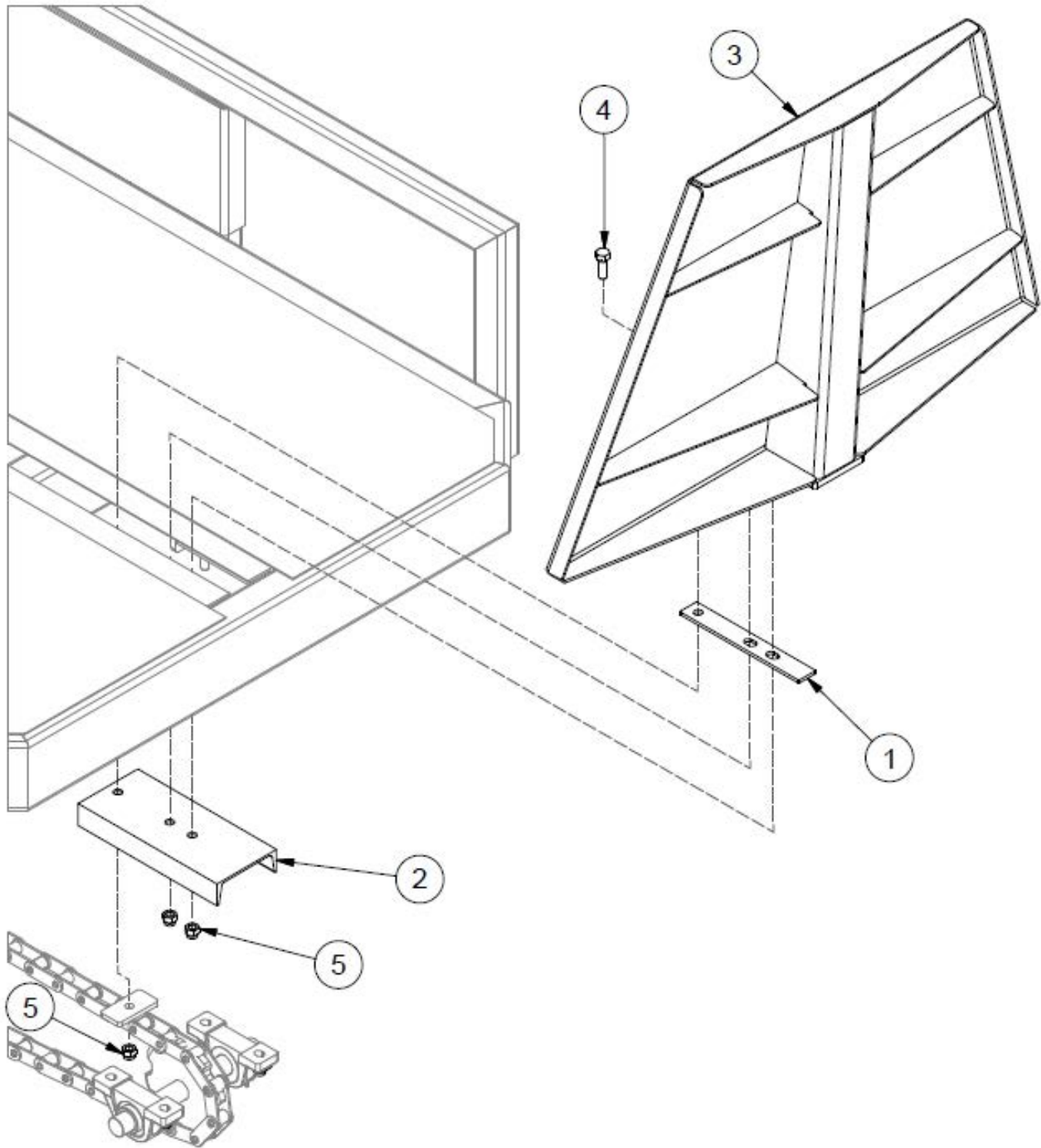

ITEM	QTY	PART NUMBER	DESCRIPTION
1	1	BS PCT200001	Bale Pusher Guide
2	1	BS SAW200013	Bale Pusher Mount
3	1	BS200003A	Bale Pusher
4	3	HB 5/8-11X1.3/4 Z5	Hex Bolt - 5/8"-11 x 1-3/4" Grade 5 Zinc Plated Hex Cap Screw NC
5	3	LN 5/8 N	Locknut - 5/8-11 Zinc Plated Nylon Insert Lock Nut

Rear Idler

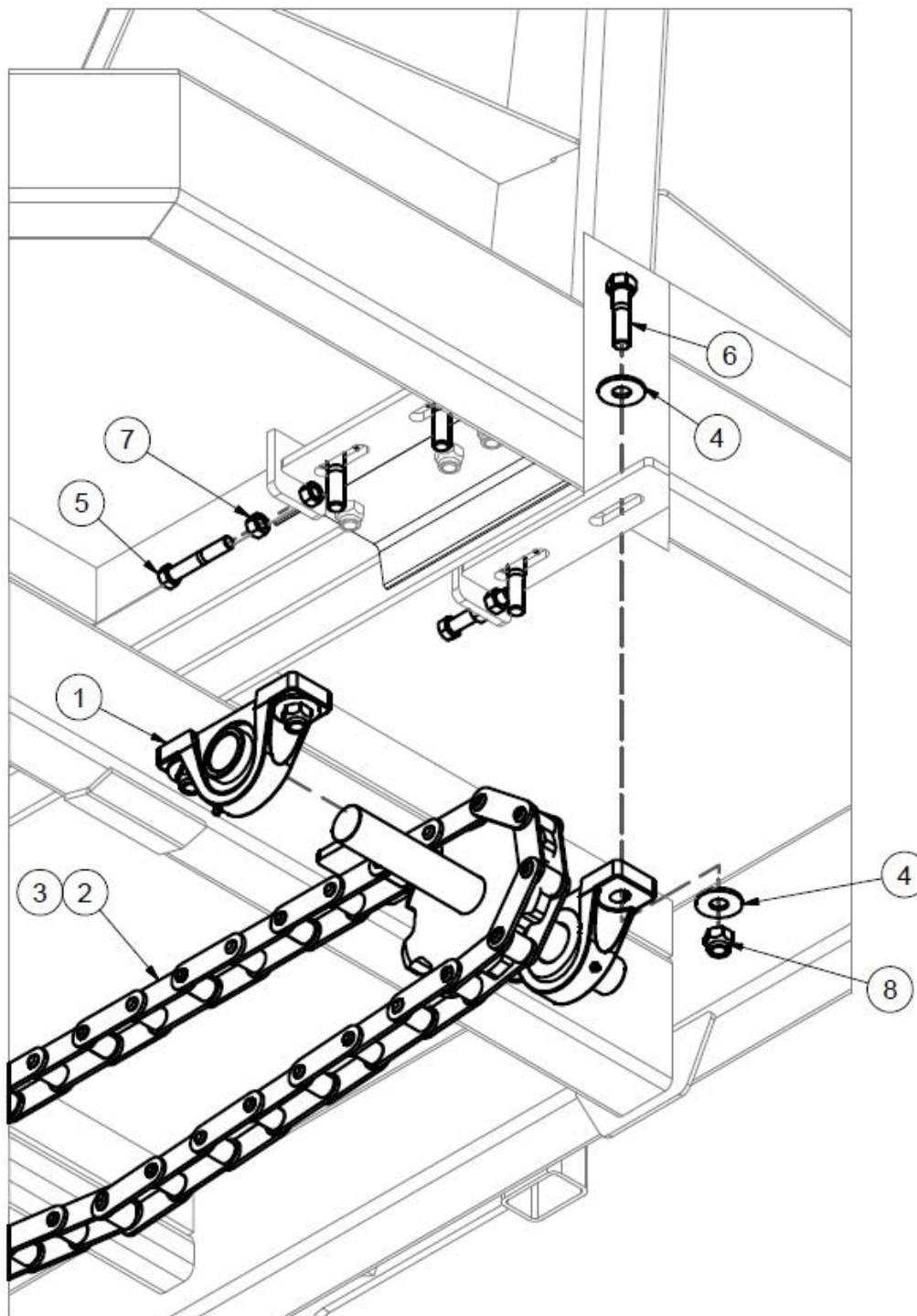

ITEM	QTY	PART NUMBER	DESCRIPTION
1	2	BEA UCP208-24R3	Pillow Block Bearing -Triple Seal- Ductile Iron
2	1	BS200145A	Conveyor Chain for Boss II
3	1	CHAIN 081X CON	Plain Chain - Connector Link
4	4	FW 5/8	Flatwasher - 5/8" Zinc Plated USS
5	2	HB 1/2-13X3.0 Z5	Hex Bolt 1/2-13 x 3" Grade 5 Zinc Plated Hex Cap Screw NC
6	4	HB 5/8-11X2.1/2 Z5	Hex Bolt 5/8-11 x 2 1/2" Grade 5 Zinc Plated Hex Cap Screw NC
7	4	HN 1/2	Hex Nut 1/2"-13 Grade 5 Zinc Plated Finished NC
8	4	LN 5/8 N	Locknut - 5/8-11 Zinc Plated Nylon Insert Lock Nut

Front Chain Drive

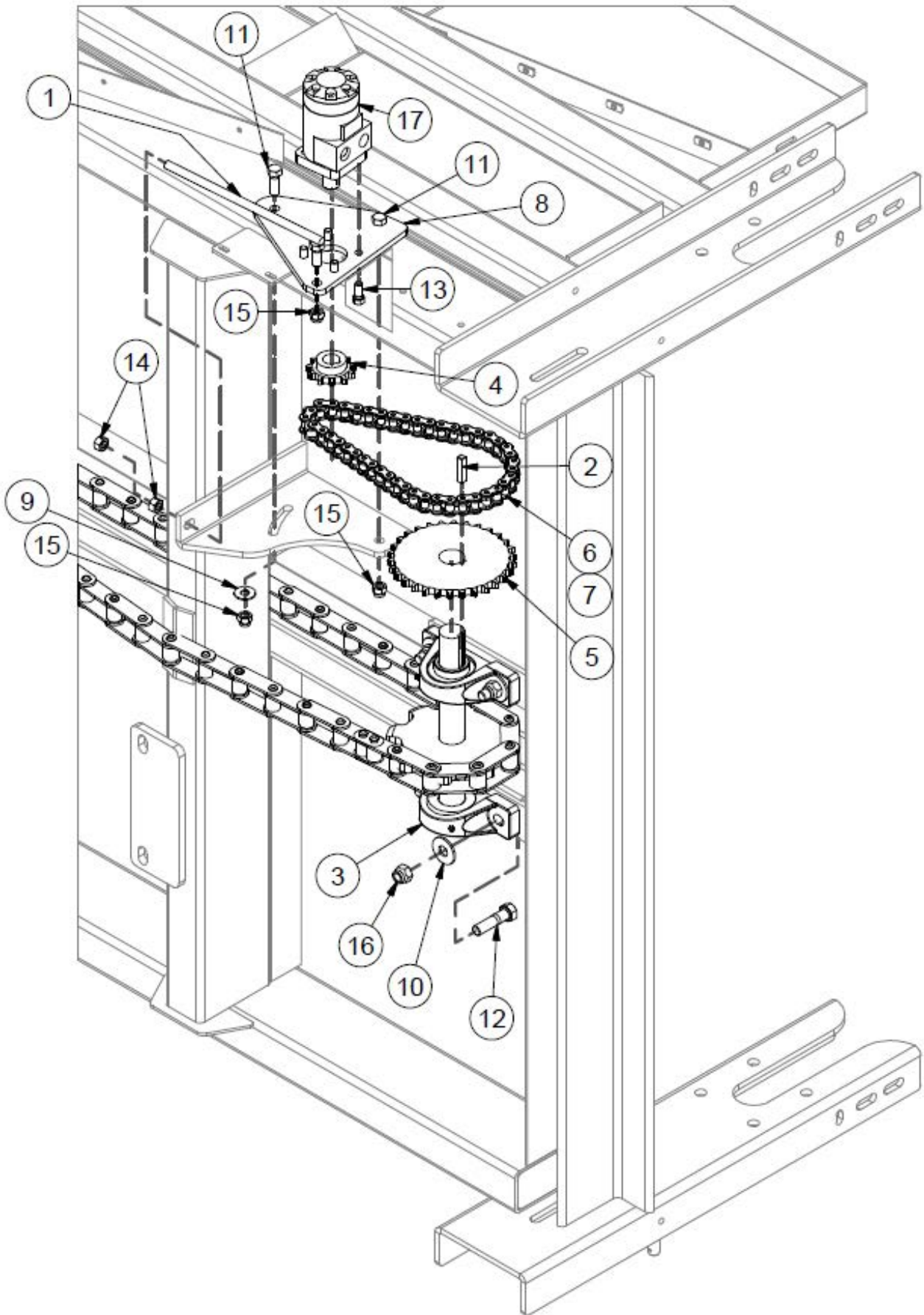

Front Chain Drive

ITEM	QTY	PART NUMBER	DESCRIPTION
1	1	27232	Chain Tightener
2	1	39505	Ram Sprocket Key
3	2	BEA UCP208-24R3	Pillow Block Bearing -Triple Seal- Ductile Iron
4	1	BS198998A	Sprocket 60B11 1.0 Bore (SPR60B11)
5	1	BS208108A	60B36 Sprocket w 1 1/2 Bore 3/8 kwy 2 5/16 ss
6	1	BS208109A	Roller Chain # 60 for Boss II Machine
7	1	BS208110A	Connector Link #60 H Con
8	1	BS208119A	Ram Motor Mount
9	3	FW 1/2	Flatwasher - 1/2" Zinc Plated USS
10	4	FW 5/8	Flatwasher - 5/8" Zinc Plated USS
11	2	HB 1/2-13X1.1/2 Z5	Hex Bolt 1/2-13 x 1 1/2" Grade 5 Zinc Plated Hex Cap Screw NC
12	4	HB 5/8-11X2.1/2 Z5	Hex Bolt 5/8-11 x 2 1/2" Grade 5 Zinc Plated Hex Cap Screw NC
13	4	HB 7/16-14X1.0 Z5	Hex Bolt Plated Gr. 5 NC
14	4	HN 1/2	Hex Nut 1/2"-13 Grade 5 Zinc Plated Finished NC
15	3	LN 1/2 N	Locknuts - 1/2-13 Zinc Plated Nylon Insert Lock Nut
16	4	LN 5/8 N	Locknut - 5/8-11 Zinc Plated Nylon Insert Lock Nut
17	1	VAL 1005	Motor, 101-1005-009 Charlynn/Eaton Hydraulic Motor

Belt Drive

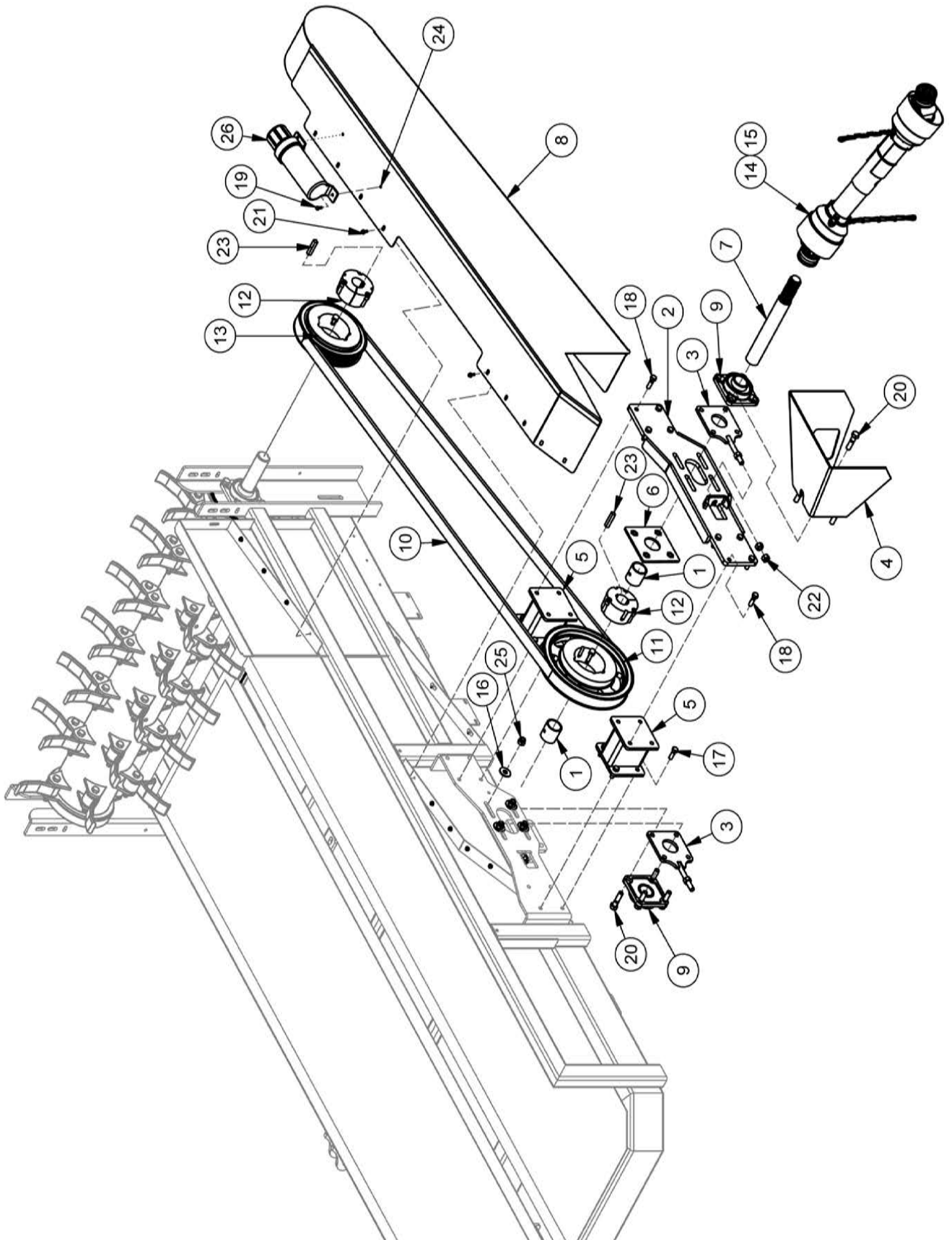

Belt Drive

ITEM	QTY	PART NUMBER	DESCRIPTION
1	2	37246	Left Side Shaft Spacer
2	1	39002	Pulley Bearing Mount
3	2	39007	Pulley Adjuster Bearing Weldment
4	1	39087	PTO Shield
5	2	39468	Boss II Spacer Assembly
6	1	39469	Boss II Nut Assembly
7	1	39492	PTO Drive Shaft
8	1	39747	Boss II Shield Weldment
9	2	BEA UCF210-32 NTL	2" Bearing 4 Bolt Ductile Iron Flange With Triple Seal
10	1	BS200165A	Main Drive Belt for BOSS II
11	1	BS208102	Sprocket 80 Tooth - BossII
12	2	BS208103	Taper Lock Hubs (BS BU3525-2GAT)
13	1	BS208104	Sprocket 60 Tooth - BossII
14	1	BS208140	PTO for Boss II 1000RPM
15	1	BS208540	PTO for Boss II 540
16	4	FW 5/8	Flatwasher - 5/8" Zinc Plated USS
17	8	HB1/2-13X1.5Z5	Hex Bolt 1/2-13x1 1/2 Grade 5 Zinc Plated Hex Cap Screw
18	8	HB1/2-13X1.75Z5	Hex Bolt 1/2-13x1 3/4 Grade 5 Zinc Plated Hex Cap Screw
19	2	HB1/4-20X0.75Z5	Hex Bolt 1/4-20x3/4 Grade 5 Zinc Plated Hex Cap Screw
20	8	HB5/8-11X2.5Z5	Hex Bolt 5/8-11x2 1/2 Grade 5 Zinc Plated Hex Cap Screw
21	12	HBC1/4X0.75	Hex Bolt Cerrated 1/4-20 x 3/4 Zinc Flange Bolt
22	6	HN5/8-11CZ5	Hex Nut 5/8"-11 Grade 5 Zinc Plated Finished
23	2	KS42434	Pulley Key
24	2	LN1/4-20NCZ5	LN 1/4-20 Zinc Plated Nylon Insert Lock Nut
25	14	LN5/8-11NCZ5	LN 5/8-11 Zinc Plated Nylon Insert Lock Nut
26	1	TL5X2-201-111	Operator's Manual Holder

5/8" Flail Drum Assembly - Up to SN 22B210

NOTE: 39495 - Complete Flail Drum can be replaced with 50079.

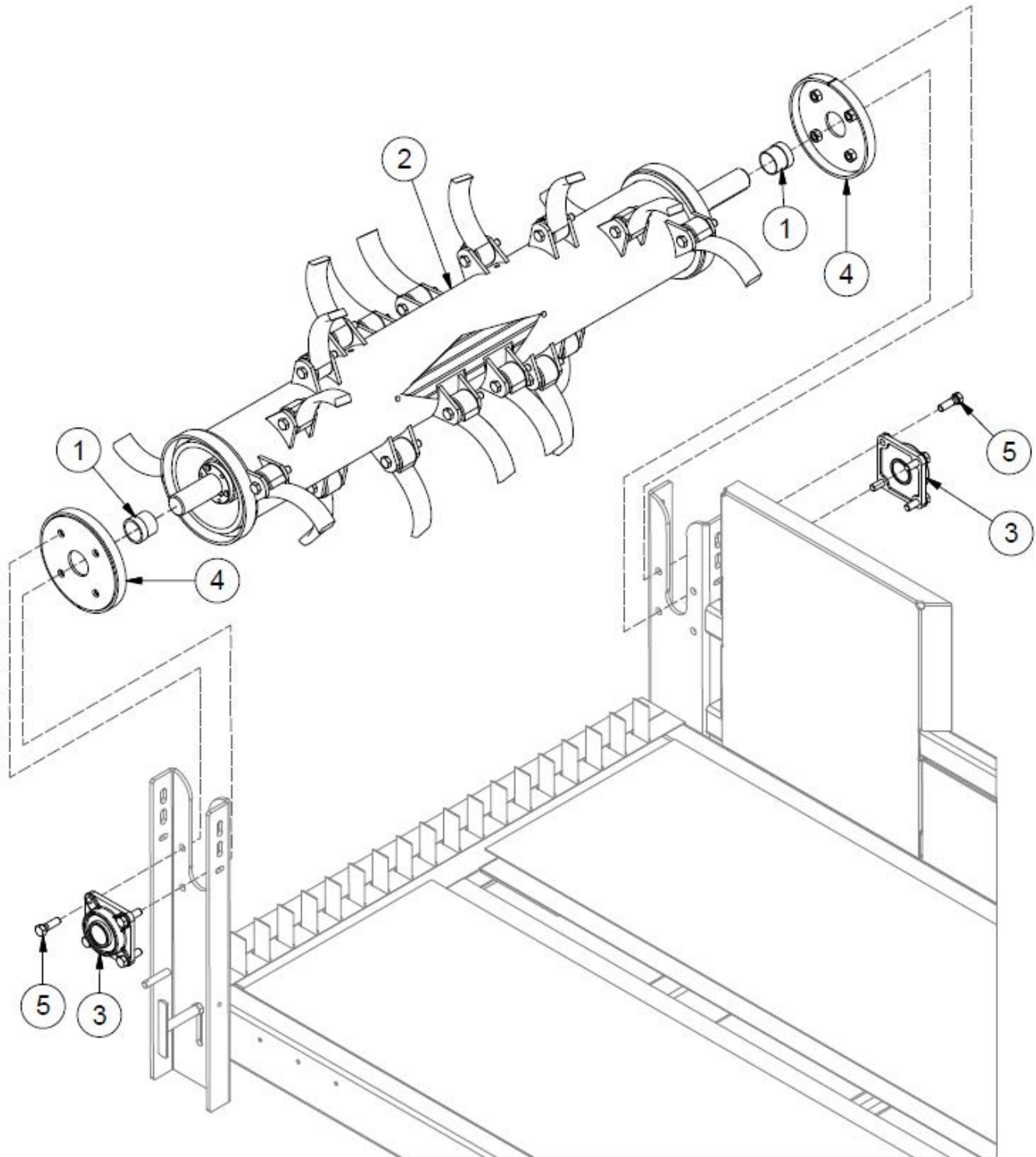

ITEM	QTY	PART NUMBER	DESCRIPTION
1	2	39102	Beater Shaft Spacer
2	1	39495	Boss II Complete Flail Drum
3	2	BEA UCF210-32 NTL	2" Bearing 4 Bolt Ductile Iron Flange With Triple Seal
4	2	BS208141	Bearing Protector for Rotor
5	8	HB 5/8-11X2 Z5	Hex Bolt 5/8-11x2 Grade 5 Zinc Plated Hex Cap Screw

5/8" Flail Drum - 39495 - Up to SN 22B210

NOTE: 39495 - Complete Flail Drum can be replaced with 50079.

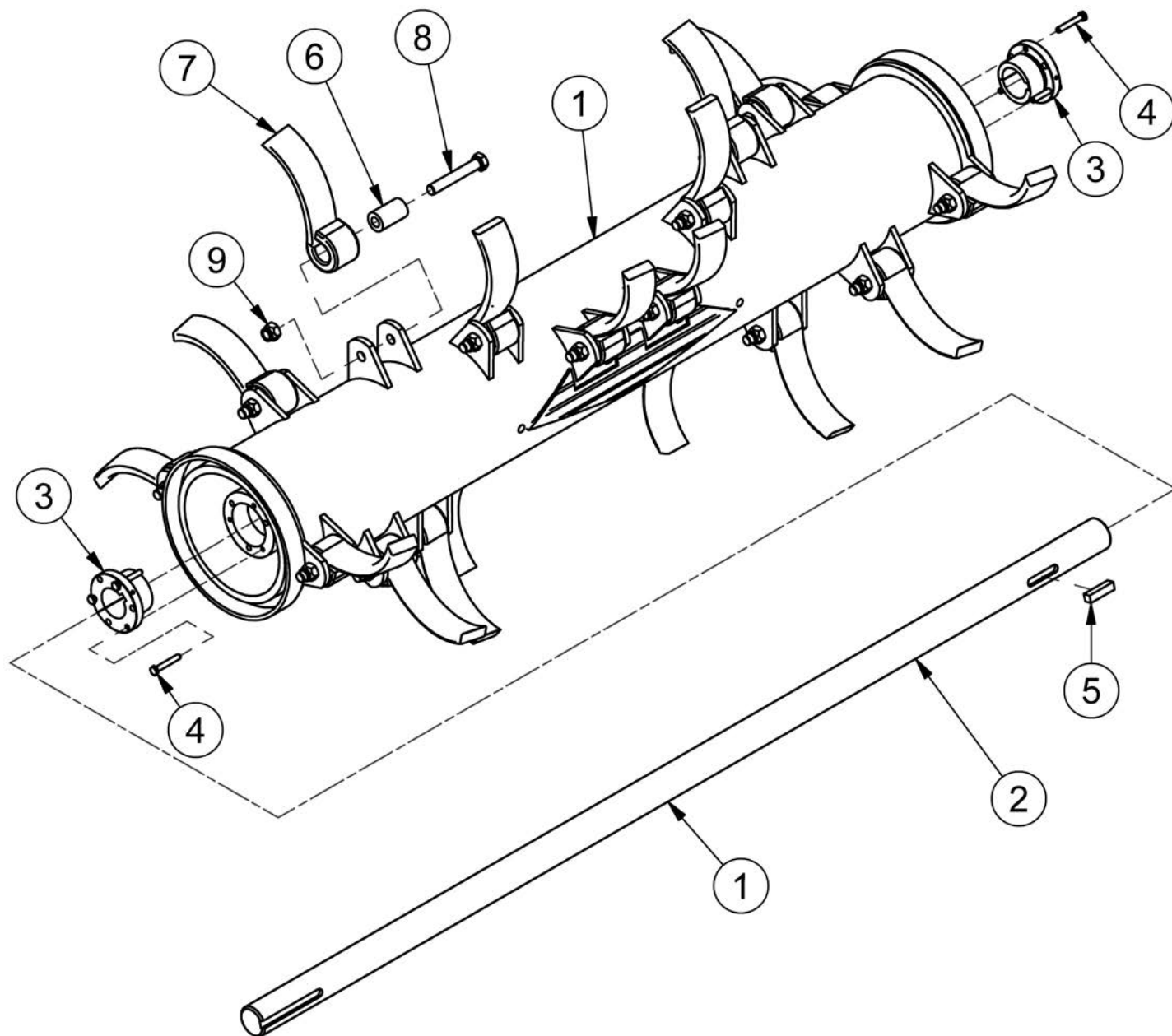

ITEM	QTY	PART NUMBER	DESCRIPTION	NOTE
1	1	39480	Flail Drum	Inc. Items 2-5
2	1	37789	Main Beater Shaft	
3	2	BS BUSK-2TBW	Bushing - SG 2" Taper Lock Insert	
4	6	HB5/16-18X2YZ8	Hex Bolt 5/16-18x2 Grade 8 Zinc Hex Cap Screw	
5	1	KS42435	Flail Drum Taper Lock Key	
6	20	BS200059	Flail Bushing	
7	20	BS200060A-2	Hammers, Heavy for Boss Shredder- 5/8 x 2.0 Material	
8	20	HB5/8-18X4YZ8	Hex Bolt 5/8-18x4 Grade 8 Zinc Hex Cap Screw	
9	20	LN5/8-18NFZ2	5/8"-18 Gr 2 Zinc Finish NE Steel Nylon Insert Lock Nut	

1/2" Flail Drum - 50079 - SN 24B201 to Current

NOTE: 39495 - Complete Flail Drum can be replaced with 50079.

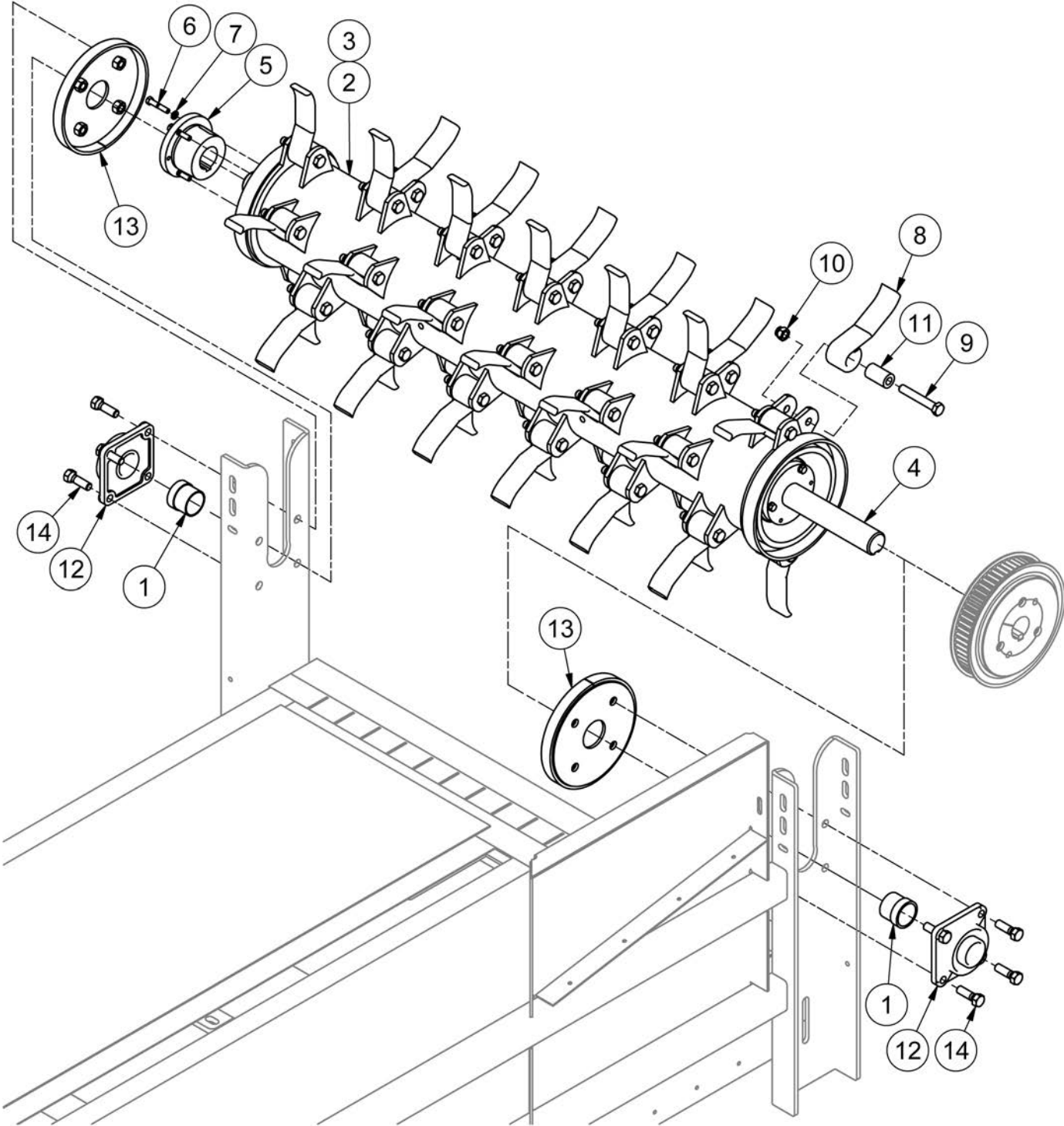

1/2" Flail Drum - 50079 - SN 24B201 to Current

NOTE: 39495 - Complete Flail Drum can be replaced with 50079.

ITEM	QTY	PART NUMBER	DESCRIPTION	NOTE
1	2	39102	Beater Shaft Spacer	
2	1	50079	Boss II HD Drum (w/flails)	Incl Items 3-11
3	1	50080	Boss II Flail Beater Weldment	
4	1	37789	Main Beater Shaft	
5	2	46982	R1x2" Split Taper Bushing	
6	6	HB3/8-16X2Z5	Hex Bolt 3/8-16x2 Grade 5 Zinc Plated Hex Cap Screw	
7	6	LW 3/8	LW - 3/8" Zinc Plated Medium Split	
8	38	CMP200113	Flail	
9	38	HB 5/8-18 X4 YZ8	Hex Bolt 5/8-18x4 Grade 8 Zinc Hex Cap Screw	
10	38	LN5/8-18NFZ2	5/8"-18 Gr 2 Zinc Finish NE Steel Nylon Insert Lock Nut	
11	38	SAW200059	Flail Bushing	
12	2	BEA UCF210-32 NTL	2" Bearing 4-Bolt Ductile Iron Flange with Triple Seal	
13	2	BS208141	Bearing Protector	
14	8	HB5/8-11X2Z5	Hex Bolt 5/8-11x2 Grade 5 Zinc Plated Hex Cap Screw	

Upper Beater

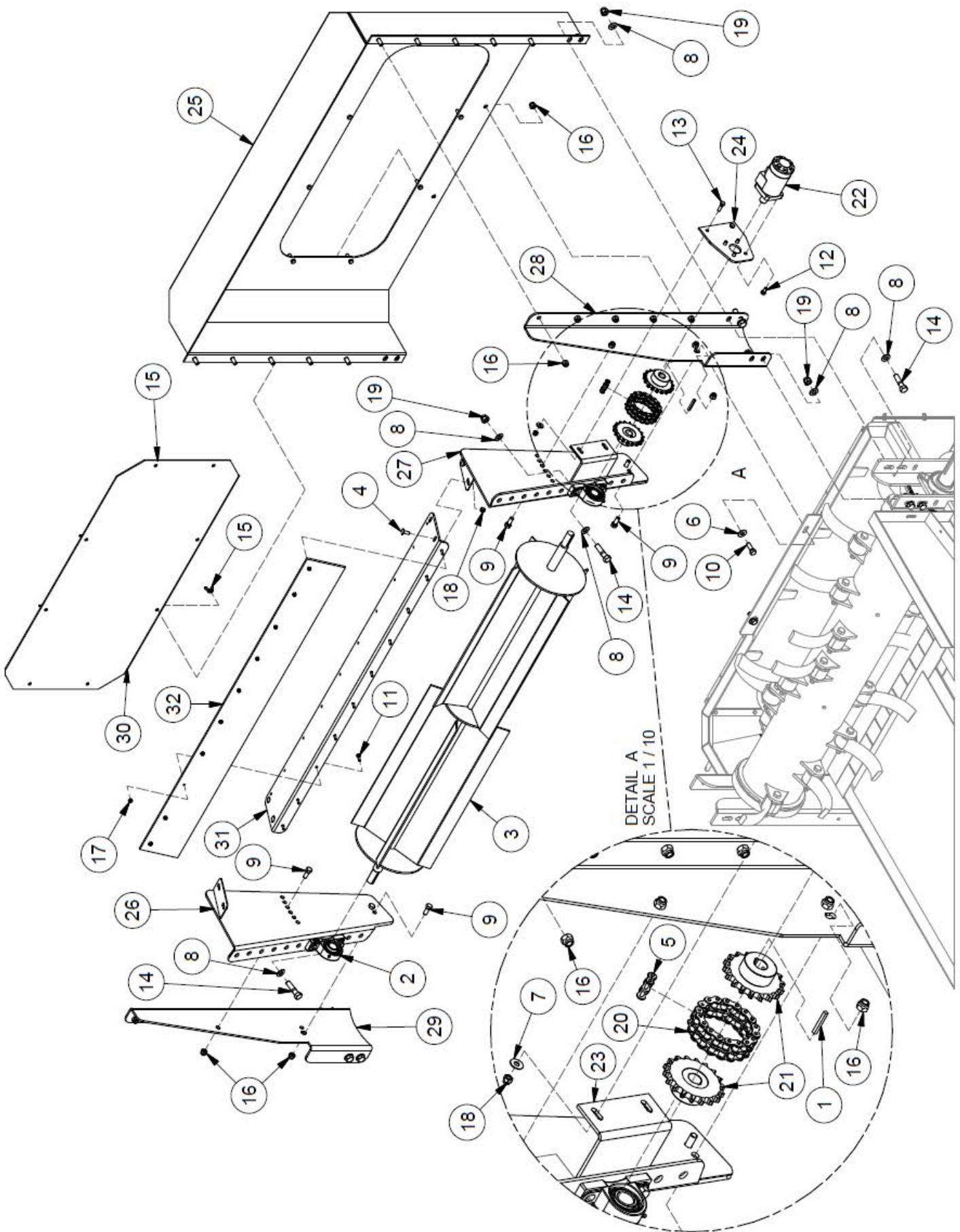

Upper Beater

ITEM	QTY	PART NUMBER	DESCRIPTION
1	1	39504	Top Beater Sprocket Key
2	2	BS208137	Pillow Block Bearing 1.25" (BEA UCP207-20)
3	1	BS208139	Top Beater Weldment
4	4	CB 3/8-16 X1 Z5	Carriage Bolt - 3/8-16 x 1" Grade 5 Zinc
5	1	D60-CON	DOUBLE #60 CHAIN
6	2	FW 1/2	Flatwasher - 1/2" Zinc Plated USS
7	6	FW 3/8	Flatwasher - 3/8" Zinc Plated USS
8	24	FW 5/8	Flatwasher - 5/8" Zinc Plated USS
9	6	HB 1/2-13X1.25 Z5	Hex Bolt 1/2-13x1 1/4 Grade 5 Zinc Plated Hex Cap Screw
10	2	HB 1/2-13X1.5 Z5	Hex Bolt 1/2-13x1 1/2 Grade 5 Zinc Plated Hex Cap Screw
11	10	HB 1/4-20X1 Z5	Hex Bolt 1/4-20x1 Grade 5 Zinc Plated Hex Cap Screw
12	4	HB 3/8-16X0.75 Z5	Hex Bolt 3/8-16x3/4 Grade 5 Zinc Plated Hex Cap Screw
13	2	HB 3/8-16X1.25 Z5	Hex Bolt 3/8-16x1 1/4 Grade 5 Zinc Plated Hex Cap Screw
14	4	HB 5/8-11X2.5 Z5	Hex Bolt 5/8-11x2 1/2 Grade 5 Zinc Plated Hex Cap Screw
15	8	HN 3/8 W	Wing Nut GR.5 Plated N.C.
16	8	LN 1/2 N	LN 1/2-13 Zinc Plated Nylon Insert Lock Nut
17	10	LN 1/4 N	LN 1/4-20 Zinc Plated Nylon Insert Lock Nut
18	6	LN 3/8 N	LN 3/8-16 Zinc Plated Nylon Insert Lock Nut
19	4	LN 5/8 N	LN 5/8-11 Zinc Plated Nylon Insert Lock Nut
20	1	SPR5014CC	Coupling Chain
21	2	SPR50B141.0	Sprocket 50B14 1.0 Bore .25 Key
22	2	VAL 1008	Motor, Hydraulic
23	1	27225	Top Beater Mount
24	1	27226	Top Beater Motor Mount
25	1	27233	Upper Hood
26	1	BS 208138	Inner Side Plate R
27	1	BS 208138M	Inner Side Plate L
28	1	BS PCT200172L	Side Adjustable Plate L
29	1	BS PCT200172R	Side Adjustable Plate R
30	1	BS PCT200174	Upper Hood Cover
31	1	BS PCT200175	Roof Top Plate Cover
32	1	BS PCT200190	Rubber Shield

Deflector

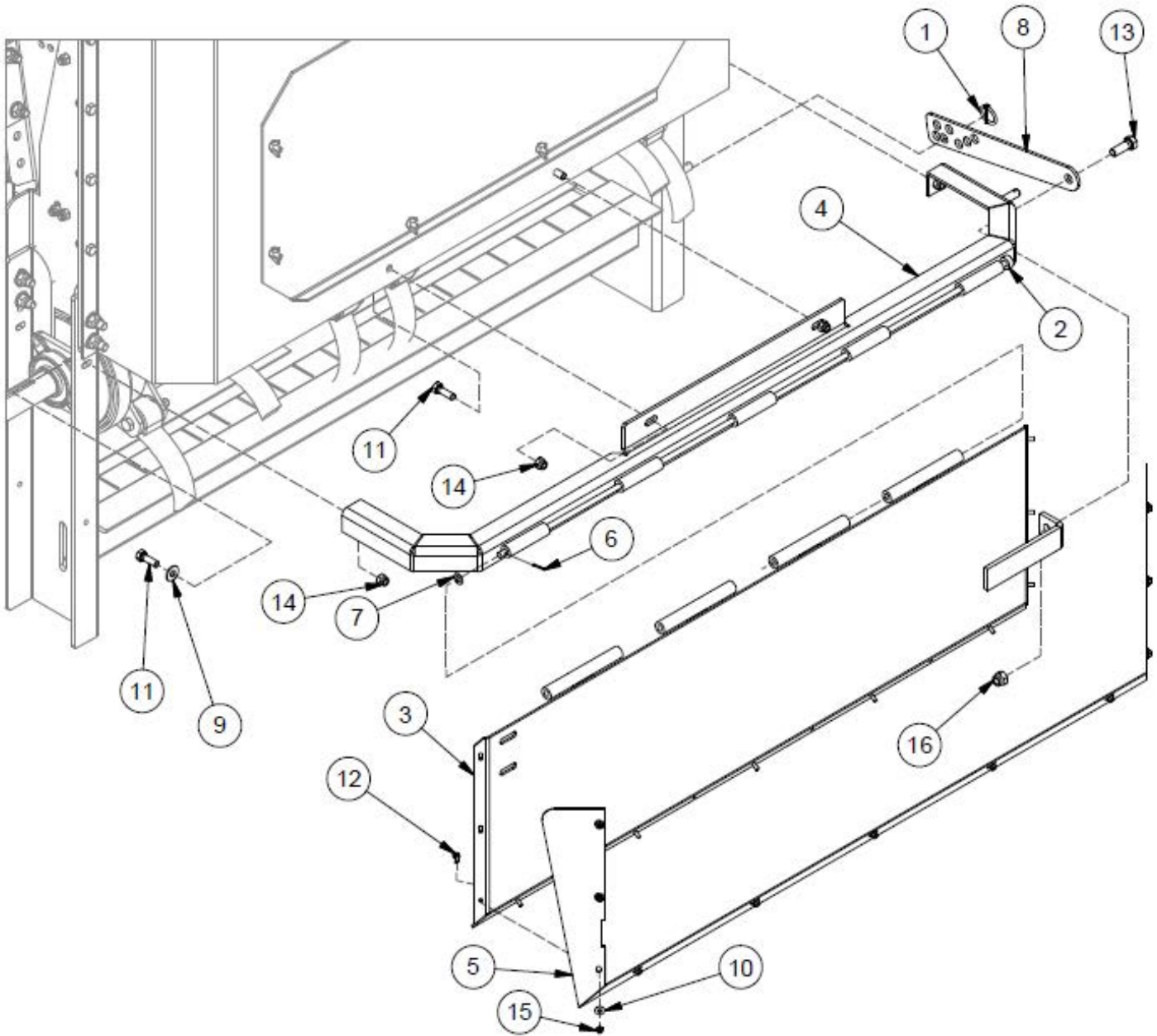

Deflector

ITEM	QTY	PART NUMBER	DESCRIPTION
1	1	25680	Lynch Pin 3/16 x 1.5
2	1	25735	Hinge Shaft
3	1	25754	Hinge Plate Weldment
4	1	BS200177	Outer Lid Support
5	1	BS208106	Boss II Side Discharge Deflector Sheild
6	1	CP 1/8 X 1 1/4	Pin, Cotter - 1/8 x 1 1/4
7	1	FW 7/16	Flatwasher - 1/2" Zinc Plated USS
8	1	BS208105	Deflector Adjuster (PCT200002)
9	2	FW 1/2	Flatwasher - 1/2" Zinc Plated USS
10	11	FW 1/4	Flatwasher - 1/4" Zinc Plated USS
11	2	HB 1/2-13X1.5 Z5	Hex Bolt 1/2-13x1 1/2 Grade 5 Zinc Plated Hex Cap Screw
12	11	HB 1/4-20X0.75 Z5	Hex Bolt 1/4-20x3/4 Grade 5 Zinc Plated Hex Cap Screw
13	1	HB 5/8-11X1.75 Z5	Hex Bolt 5/8-11x1 3/4 Grade 5 Zinc Plated Hex Cap Screw
14	4	LN 1/2 N	LN 1/2-13 Zinc Plated Nylon Insert Lock Nut
15	11	LN 1/4 N	LN 1/4-20 Zinc Plated Nylon Insert Lock Nut
16	1	LN 5/8 N	LN 5/8-11 Zinc Plated Nylon Insert Lock Nut

Hydraulic Layout

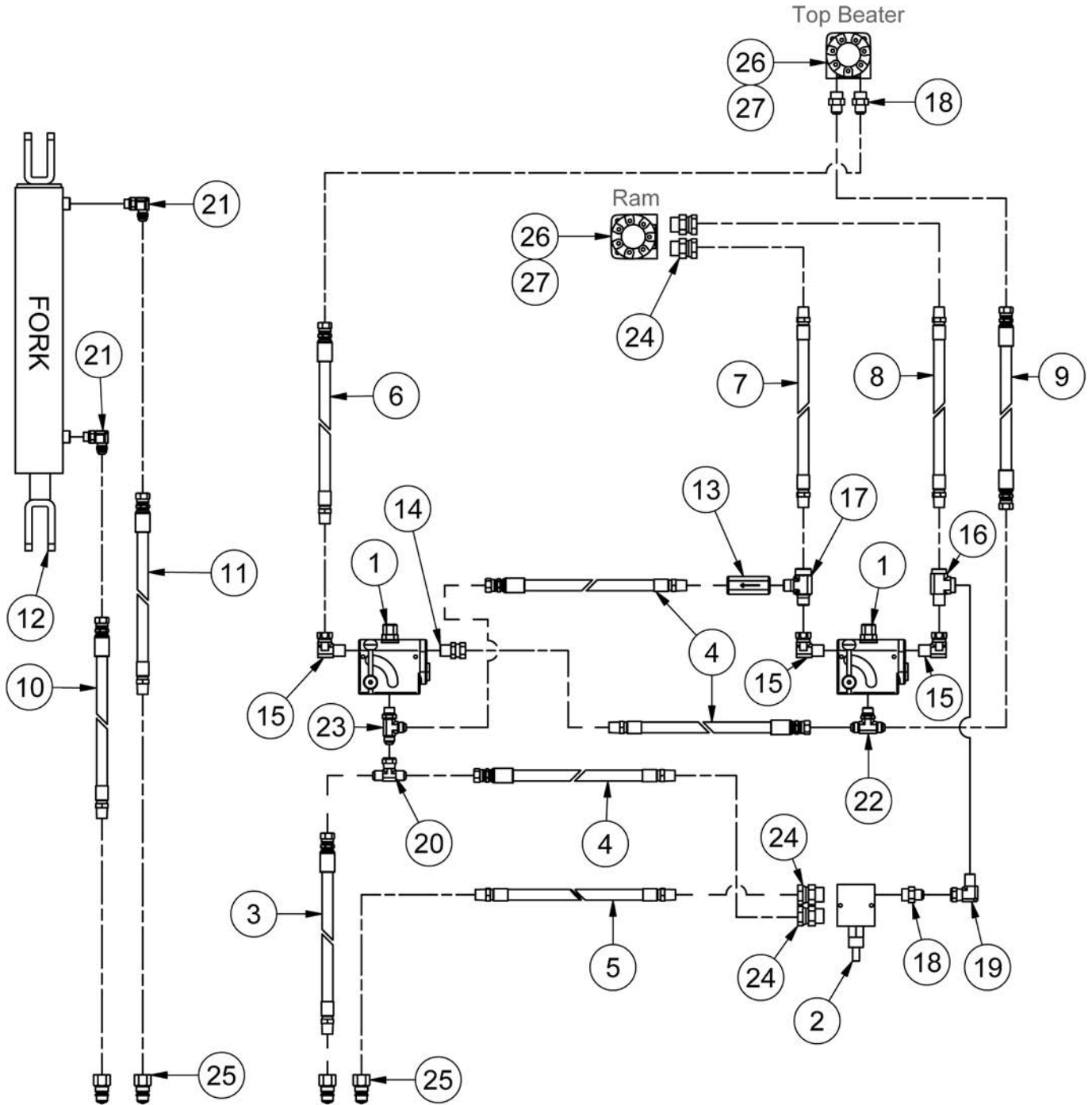

Hydraulic Layout

ITEM	QTY	PART NUMBER	DESCRIPTION
1	2	42701	Flow Control Valve with Relief
2	1	42702	Relief Valve
3	1	BS-01	HH128 - R17-08 3000PSI/109-08/MNPT/08FJIC/128 C/W C402-08
4	3	BS-03	HH16 - R17-08 3000PSI/109-08/MNPT08/FJIC08/16
5	1	BS-04	HH150 - R17-08 3000PSI/109-08/MNPT08/MNPT08/150 C/W C402-08
6	1	BS-05	HH96 - R17-063000PSI/109-06/FJIC08/MNPT-08/96
7	1	BS-06	HH40 - R17-063000PSI/109-06/MNPT-08/40
8	1	BS-07	HH27 - R17-063000PSI/109-06/MNPT-08/27
9	1	BS-08	HH68 - R17-063000PSI/109-06/FJIC08/68
10	1	BS-09	HH120 - R17-063000PSI/109-08/MNPT-08/FJIC08/120C/MNPT-08
11	1	BS-10	HH140 - R17-063000PSI/109-06/MNPT-08/FJIC08/140C/MNPT-08
12	1	BS199899A	Cylinder, Boss II Fork (Lift) - 3-1/2" X 20-1/2" Hydraulic Cylinder
13	1	BS208117A	Check Valve 1/2"
14	1	HF 1404-8-8	Male NPT x Female NPSM Adapter
15	3	HF 1501-8-8	1/2 Male Pipe to Female Pipe 90 Swivel
16	1	HF 5602-8-8-8	Hyd. Fitting Female Tee
17	1	HF 5603-8-8-8	Hydraulic T Fitting
18	3	HF 6400-8-10	Hyd Fitting - Male JIC - Male ORB
19	1	HF 6501-8-8	Hyd Fitting 90 Degree
20	1	HF 6600-8-8-8	Hyd. Fitting - Male JIC - Female JIC Tee
21	2	HF 6801-8-8	Hyd. Fitting- 1/2" JIC- 1/2" SAE 90 Deg Elbow
22	1	HF 6803-8-8-8	Hyd. Fitting Male JIC Male JIC Male ORB Tee
23	1	HF 6804-8-8-8	Hydraulic Tee Fitting
24	4	HF 6900-10-8	Hydraulic Fitting
25	4	HF 8010-4	Quickcoupler 1/2" Male Tip
26	2	VAL 1008	Motor, Hydraulic - (BS208107A)
27	2	SKMLHPQUDE	Seal Kit for 200 & 400 Series Motors (for MLHPQ-U/D)

Hydraulic Flow

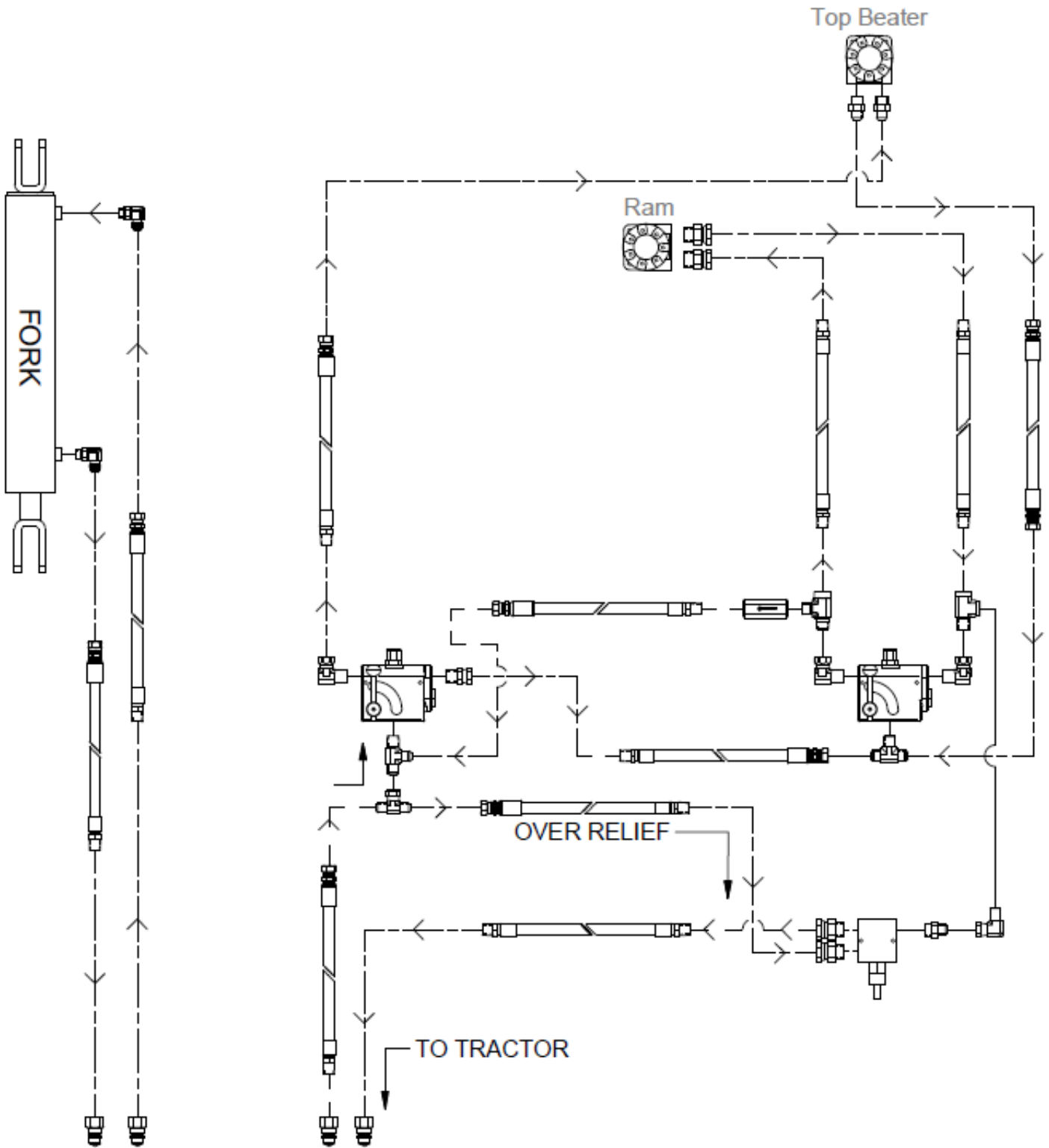

Hydraulic Flow

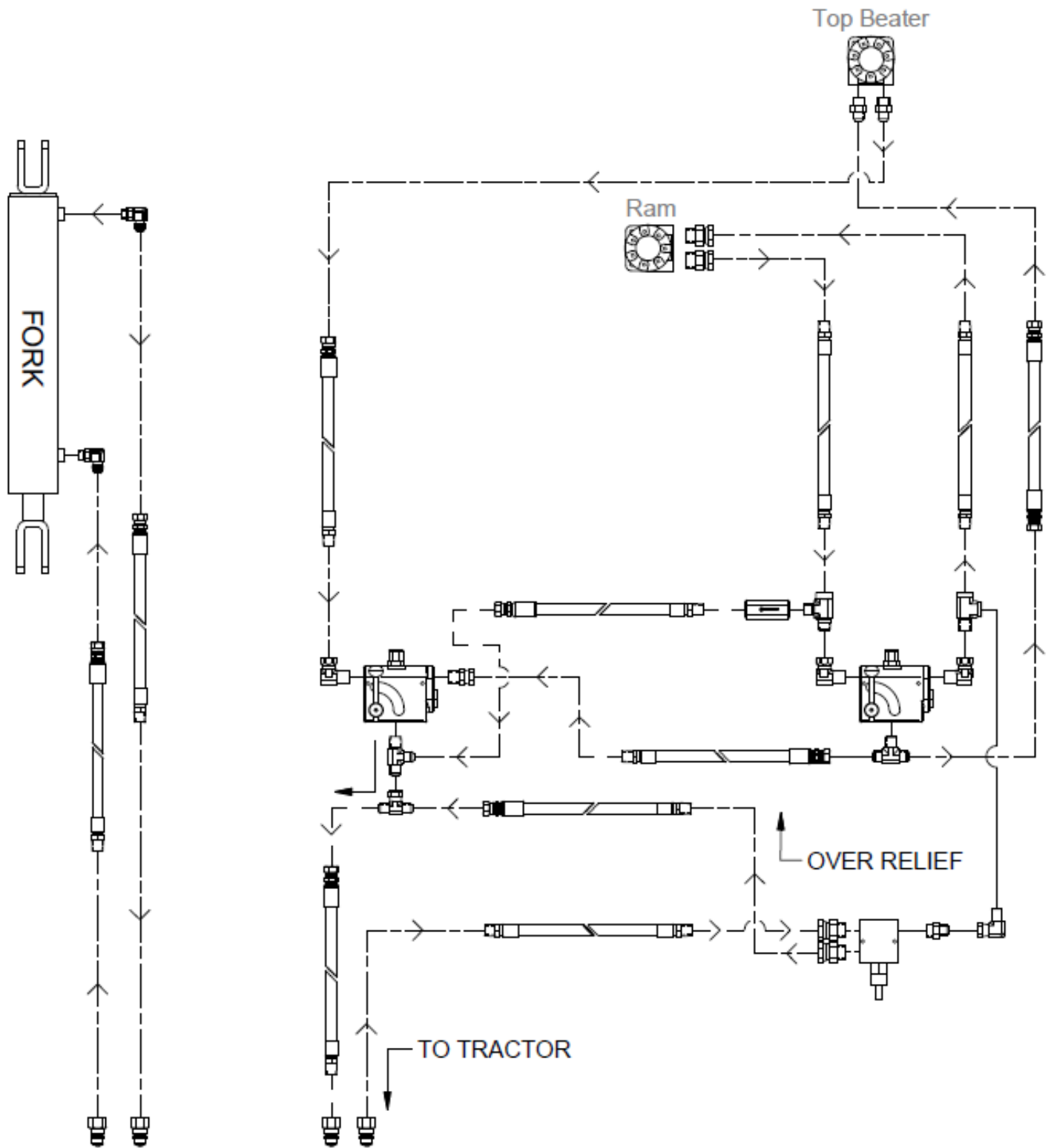

Section 9: Options

Knife Kit Option

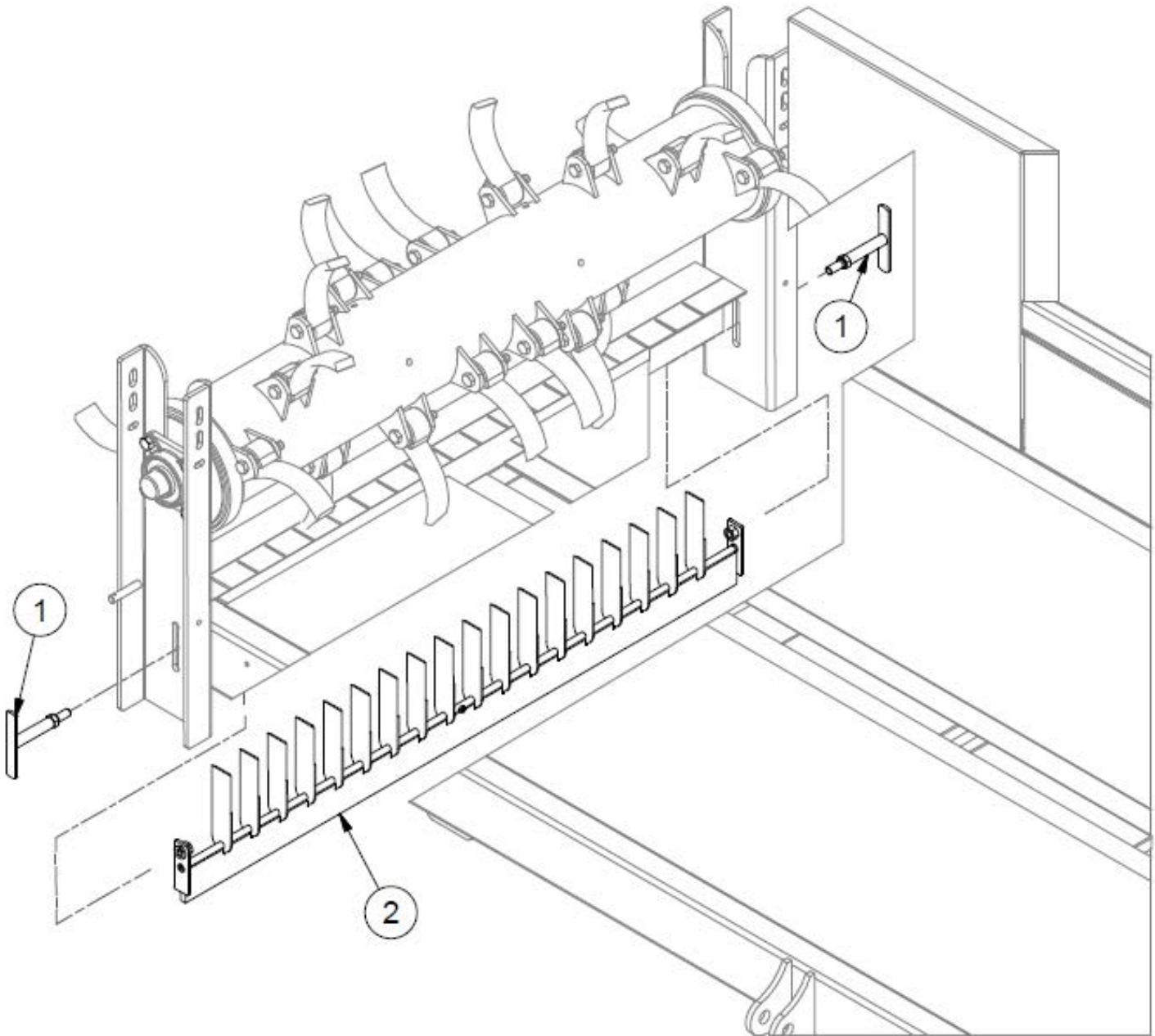

ITEM	QTY	PART NUMBER	DESCRIPTION
1	2	BS200038	Tee Handle
2	1	27234	Knife Assembly

Electric Actuator Option

Used until serial number : 17B240

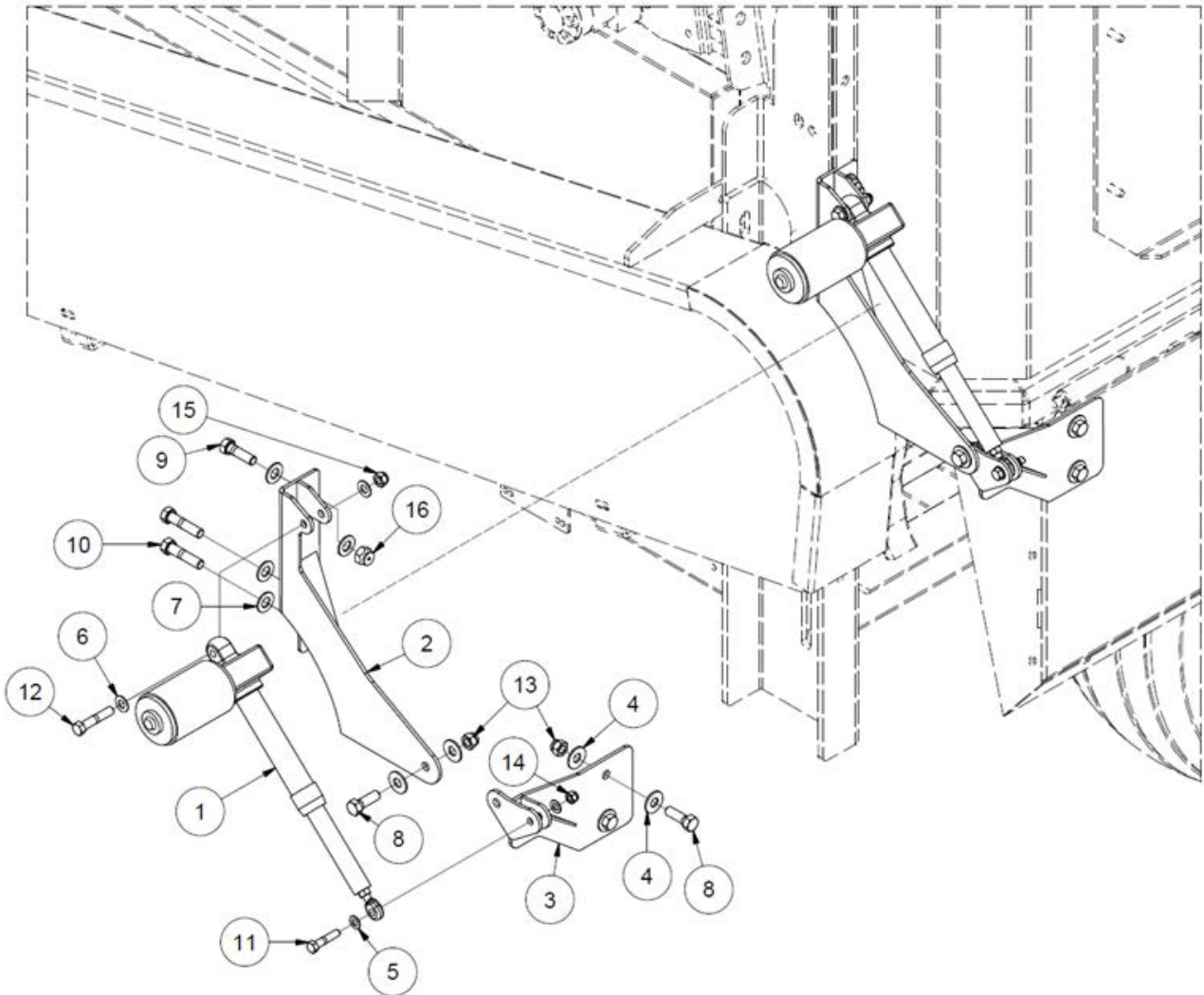

ITEM	QTY	PARTNUMBER	DESCRIPTION
1	1	31929	Actuator Deflector Pivot
2	1	31930	Actuator Pivot
3	1	32702	Electric Actuator
4	6	FW 1/2	Flat Washer
5	2	FW 3/8	Flat Washer
6	2	FW 7/16	Flat Washer
7	6	FW 9/16	Flat Washer
8	3	HB 1/2 X 1 1/2	Hex Bolt
9	1	HB 1/2 X 1 3/4	Hex Bolt
10	2	HB 1/2 X 2 1/4	Hex Bolt
11	1	HB 3/8 X 1 3/4	Hex Bolt
12	1	HB 7/16 X 2 1/4	Hex Bolt
13	3	LN 1/2	Lock Nut
14	1	LN 3/8	Lock Nut
15	1	LN 7/16	Lock Nut
16	3	LN 9/16	Lock Nut

33207 - Electric Actuator Wiring Harness

Hydraulic Actuator Option

Used from Serial Number : 17B247

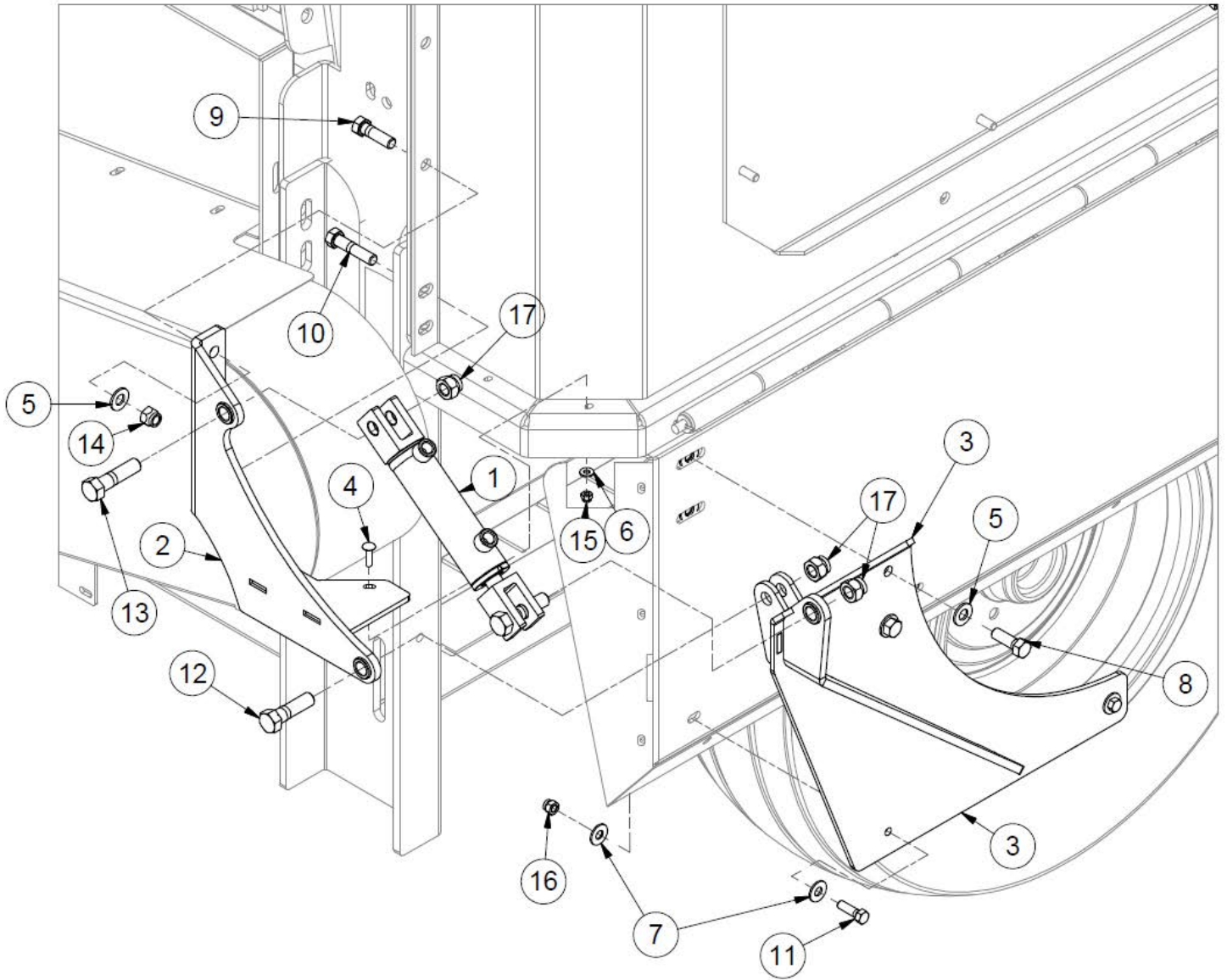

Hydraulic Actuator Option

Used from Serial Number : 17B247

ITEM	QTY	PART NUMBER	DESCRIPTION
	1	42294	Boss II Hydraulic Actuator Kit
1	1	31326	Hydraulic Cylinder for Nitro Light Kits
2	1	42295	Hydraulic Actuator Pivot
3	1	42299	Hydraulic Actuator Deflector Pivot
4	2	CB 1/4-20 X1 Z5	Carriage Bolt - 1/4-20 x 1" Grade 5 Zinc
5	8	FW 1/2	Flatwasher - 1/2" Zinc Plated USS
6	2	FW 1/4	Flatwasher - 1/4" Zinc Plated USS
7	4	FW 3/8	Flatwasher - 3/8" Zinc Plated USS
8	2	HB 1/2-13X1.5 Z5	Hex Bolt 1/2-13x1 1/2 Grade 5 Zinc Plated Hex Cap Screw
9	1	HB 1/2-13X1.75 Z5	Hex Bolt 1/2-13x1 3/4 Grade 5 Zinc Plated Hex Cap Screw
10	1	HB 1/2-13X2.25 Z5	Hex Bolt 1/2-13x2 1/4 Grade 5 Zinc Plated Hex Cap Screw
11	2	HB 3/8-16X1.25 Z5	Hex Bolt 3/8-16x1 1/4 Grade 5 Zinc Plated Hex Cap Screw
12	1	HB 5/8-11X2.25 Z5	Hex Bolt 5/8-11x2 1/4 Grade 5 Zinc Plated Hex Cap Screw
13	2	HB 5/8-11X2.5 Z5	Hex Bolt 5/8-11x2 1/2 Grade 5 Zinc Plated Hex Cap Screw
14	4	LN 1/2 N	LN 1/2-13 Zinc Plated Nylon Insert Lock Nut
15	2	LN 1/4 N	LN 1/4-20 Zinc Plated Nylon Insert Lock Nut
16	2	LN 3/8 N	LN 3/8-16 Zinc Plated Nylon Insert Lock Nut
17	3	LN 5/8 N	LN 5/8-11 Zinc Plated Nylon Insert Lock Nut

Hydraulic Actuator Option Layout

Used from Serial Number : 17B247

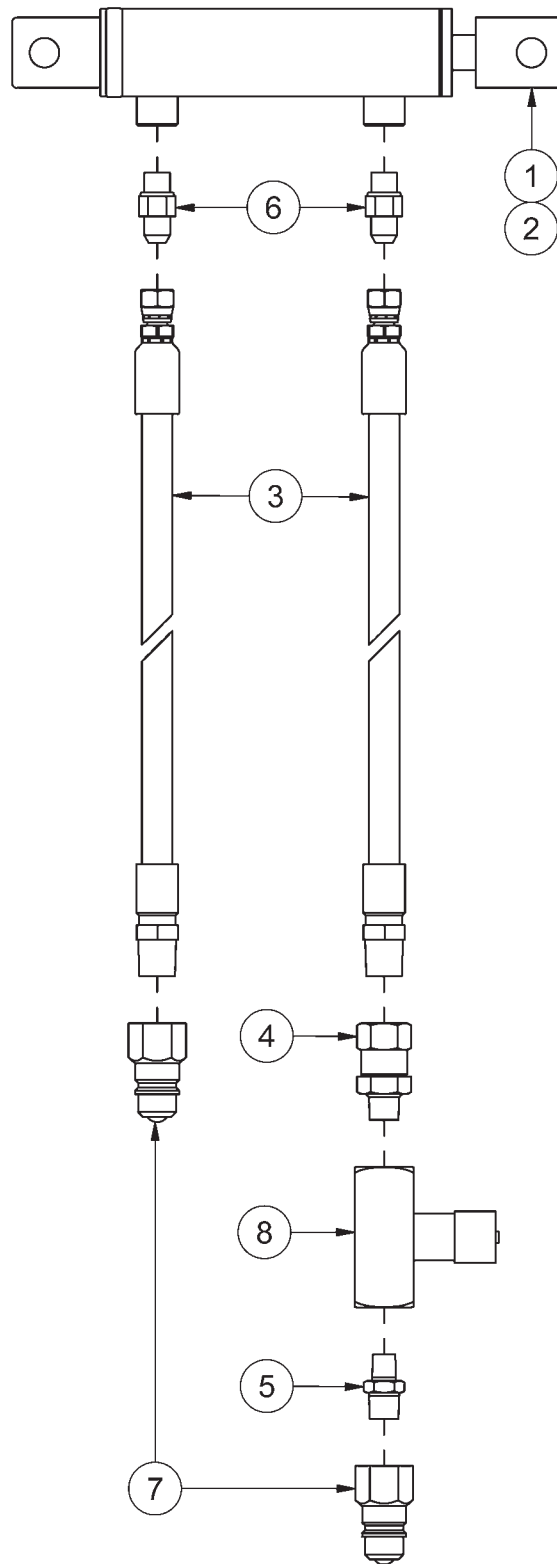

Hydraulic Actuator Option Layout











Used from Serial Number : 17B247

ITEM	QTY	PART NUMBER	DESCRIPTION
1	1	31326	Hydraulic Cylinder for Nitro Light Kits
2	1	SK SLK-1510	Seal Kit
3	2	43793	Hose - HH192 - 6G(8MP,6FJX) HCL 192"
4	1	HF 1404-6-8	Hyd Fitting 3/8 MPT - 1/2 FPX
5	1	HF 5404-8-6	Hyd Fitting 1/2 MPT - 3/8 MPT
6	2	HF 6400-6-6	Hydraulic Fitting - Male JIC - Male ORB
7	2	HF 8010-4	Quickcoupler 1/2" Male Tip
8	1	TL550-200-006	Steering Speed Control (Needle Valve)

BS208140 - 1000RPM PTO

ITEM	QTY	PART NUMBER	DESCRIPTION
1	1	PTO145.285.014.1	Complete Overrunning Clutch R14 (3800Nm)
2	2	PTO180.018.537	Cross Journal Set
5	1	PTO151.018.133.1	Outer Yoke
11	1	PTO190.000.243	Roll Pin for Outer Tube
12	1	PTO180.018.446	Wiper
14	1	PTO152.198.183.0720	Complete Outer Tube
20	1	PTO180.017.411	Grease Nipple for Lube
30	1	PTO144.386.063.1	Complete Automatic Torque Limiter LA4 (2700Nm)
31	1	PTO180.018.251	Guard Retaining Collar for Outer Tube
33	6	PTO180.014.240	Bolt
37	1	PTO180.018.252	Guard Retaining Collar for Inner Tube
38	2	PTO180.016.790	Safety Chains
40	1	PTO142.286.274.7821	Complete Guard with Instruction Manual
51	1	PTO141.028.210.1	Outer Casting With Yoke
52	1	PTO190.000.020	Grease Nipple M8x1
53	1	PTO190.000.199	Retaining Washer
54	3	PTO180.014.137	Leaf Spring
55	3	PTO151.014.136	Ratchet
56	1	PTO151.014.200	Hub R14 (1.75 Z6)
57	1	PTO180.014.135	Retaining Washer
58	1	PTO190.000.183	Inner Circlip
59	2	PTO165.000.622	Bolt M14x1.5x100 & Nut
60	2	PTO151.014.201	Bridge
71	1	PTO141.028.651.1	Yolk Support for Automatic Torque Limiter LA
72	1	PTO180.017.478	Inner Bushing
73	1	PTO141.027.616.2	Cartridge Limiter LA 2700Nm
74	4	PTO180.017.482	Ratchet Tooth LA
75	4	PTO190.000.845	Glycudor Bushing
76	1	PTO141.027.572.1	Hub LA4
77	1	PTO165.000.589	Tapered Pin Set 1.75"
78	1	PTO180.017.479	Outer Bushing
79	1	PTO19020.550.020	Oil Seal BASL
80	1	PTO18.7.6.01421	O-Ring
81	1	PTO19010.641.501	Cover for LA Limiter
82	1	PTO122.380.070.1	Snap Ring
90	1	PTO122.380.549.1	Female Tube with Yoke and Lube System
91	1	PTO142.283.274.7821	Male Tube with Yoke and Lube System
94	1	PTO142.287.170.7821	Half Female Guarding with Label
95	1	PTO123.380.463.11	Half Male Guarding
96	1	PTO123.480.751.11	Half Female Shaft with Guarding
97	1	PTO190.000.216	Half Male Shaft with Guarding
98	1	PTO190.000.215	DANGER Label for Outer Tube
99	1	PTO190.000.215	DANGER Label for Outer Guard Tube
100	1	PTO190.000.371	Instruction Manual
101	1	PTO180.018.341	Plastic Cap for Outer Tube

Imperial Torque Values

SAE Grade and Head Markings	NO MARK	1 or 2 ^b	5	5.1	5.2	8	8.2
							
SAE Grade and Nut Markings	NO MARK	2	5		8		
							

Size	Grade 1				Grade 2 ^b				Grade 5, 5.1, or 5.2				Grade 8 or 8.2			
	Lubricated ^a		Dry ^a		Lubricated ^a		Dry ^a		Lubricated ^a		Dry ^a		Lubricated ^a		Dry ^a	
	N-m	lb-ft	N-m	lb-ft	N-m	lb-ft	N-m	lb-ft	N-m	lb-ft	N-m	lb-ft	N-m	lb-ft	N-m	lb-ft
1/4	3.7	2.8	4.7	3.5	6	4.5	7.5	5.5	9.5	7	12	9	13.5	10	17	12.5
5/16	7.7	5.5	10	7	12	9	15	11	20	15	25	18	28	21	35	26
3/8	14	10	17	13	22	16	27	20	35	26	44	33	50	36	63	46
7/16	22	16	28	20	35	26	44	32	55	41	70	52	80	58	100	75
1/2	33	25	42	31	53	39	67	50	85	63	110	80	120	90	150	115
9/16	48	36	60	45	75	56	95	70	125	90	155	115	175	130	225	160
5/8	67	50	85	62	105	78	135	100	170	125	215	160	240	175	300	225
3/4	120	87	150	110	190	140	240	175	300	225	375	280	425	310	550	400
7/8	190	140	240	175	190	140	240	175	490	360	625	450	700	500	875	650
1	290	210	360	270	290	210	360	270	725	540	925	675	1050	750	1300	975
1-1/8	400	300	510	375	400	300	510	375	900	675	1150	850	1450	1075	1850	1350
1-1/4	570	425	725	530	570	425	725	530	1300	950	1650	1200	2050	1500	2600	1950
1-3/8	750	550	950	700	750	550	950	700	1700	1250	2150	1550	2700	2000	3400	2550
1-1/2	1000	725	1250	925	990	725	1250	930	2250	1650	2850	2100	3600	2650	4550	3350

DO NOT use these values if a different torque value or tightening procedure is given for a specific application. Torque values listed are for general use only. Check tightness of fasteners periodically.

Shear bolts are designed to fail under predetermined loads. Always replace shear bolts with identical grade.

Fasteners should be replaced with the same or higher grade. If higher grade fasteners are used, these should only be tightened to the strength of the original.

Make sure fasteners threads are clean and that you properly start thread engagement. This will prevent them from failing when tightening.

Tighten plastic insert or crimped steel-type lock nuts to approximately 50 percent of the dry torque shown in the chart, applied to the nut, not to the bolt head. Tighten toothed or serrated-type lock nuts to the full torque value.

^a "Lubricated" means coated with a lubricant such as engine oil, or fasteners with phosphate and oil coatings. "Dry" means plain or zinc plated without any lubrication.

^b Grade 2 applies for hex cap screws (not hex bolts) up to 152 mm (6-in.) long. Grade 1 applies for hex cap screws over 152 mm (6-in.) long, and for all other types of bolts and screws of any length.

Metric Torque Values

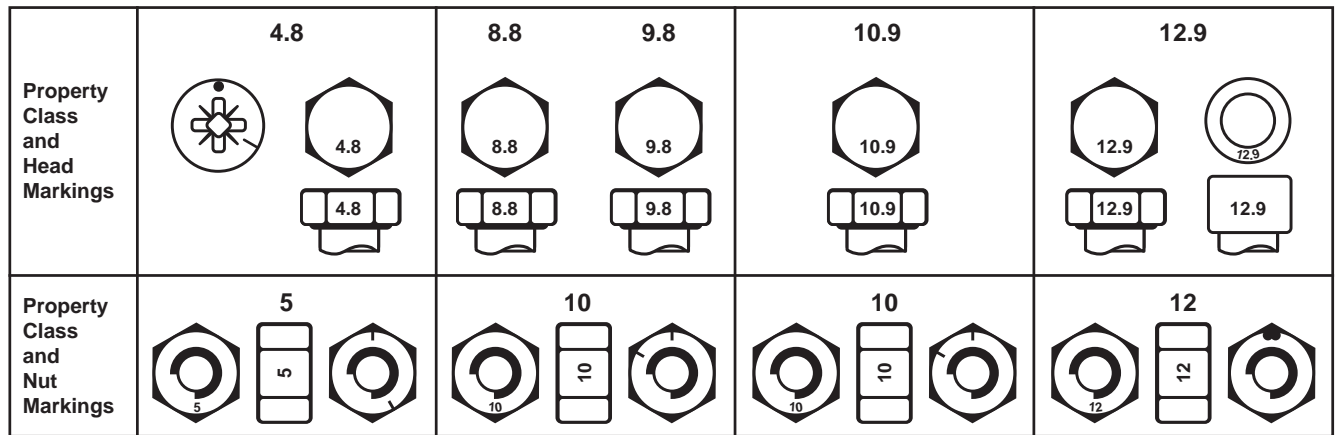

Size	Class 4.8				Class 8.8 or 9.8				Class 10.9				Class 12.9			
	Lubricated ^a		Dry ^a		Lubricated ^a		Dry ^a		Lubricated ^a		Dry ^a		Lubricated ^a		Dry ^a	
	N-m	lb-ft	N-m	lb-ft	N-m	lb-ft	N-m	lb-ft	N-m	lb-ft	N-m	lb-ft	N-m	lb-ft	N-m	lb-ft
M6	4.8	3.5	6	4.5	9	6.5	11	8.5	13	9.5	17	12	15	11.5	19	14.5
M8	12	8.5	15	11	22	16	28	20	32	24	40	30	37	28	47	35
M10	23	17	29	21	43	32	55	40	63	47	80	60	75	55	95	70
M12	40	29	50	37	75	55	95	70	110	80	140	105	130	95	165	120
M14	63	47	80	60	120	88	150	110	175	130	225	165	205	150	260	190
M16	100	73	125	92	190	140	240	175	275	200	350	255	320	240	400	300
M18	135	100	175	125	260	195	330	250	375	275	475	350	440	325	560	410
M20	190	140	240	180	375	275	475	350	530	400	675	500	625	460	800	580
M22	260	190	330	250	510	375	650	475	725	540	925	675	850	625	1075	800
M24	330	250	425	310	650	475	825	600	925	675	1150	850	1075	800	1350	1000
M27	490	360	625	450	950	700	1200	875	1350	1000	1700	1250	1600	1150	2000	1500
M30	675	490	850	625	1300	950	1650	1200	1850	1350	2300	1700	2150	1600	2700	2000
M33	900	675	1150	850	1750	1300	2200	1650	2500	1850	3150	2350	2900	2150	3700	2750
M36	1150	850	1450	1075	2250	1650	2850	2100	3200	2350	4050	3000	3750	2750	4750	3500

DO NOT use these values if a different torque value or tightening procedure is given for a specific application. Torque values listed are for general use only. Check tightness of fasteners periodically.

Shear bolts are designed to fail under predetermined loads. Always replace shear bolts with identical property class.

Fasteners should be replaced with the same or higher property class. If higher property class fasteners are used, these should only be tightened to the strength of the original.

Make sure fasteners threads are clean and that you properly start thread engagement. This will prevent them from failing when tightening.

Tighten plastic insert or crimped steel-type lock nuts to approximately 50 percent of the dry torque shown in the chart, applied to the nut, not to the bolt head. Tighten toothed or serrated-type lock nuts to the full torque value.

^a "Lubricated" means coated with a lubricant such as engine oil, or fasteners with phosphate and oil coatings. "Dry" means plain or zinc plated without any lubrication.

Index

1/2" Flail Drum - 50079 - SN 24B201 to Current	8-14
5/8" Flail Drum Assembly - Up to SN 22B210	8-12
Adjustments4-1
After Every 10 Hours of Operation6-2
Bale Pusher Assembly7-8
Bale Sizes1-1
Before First Use4-1
Belt Drive	8-10
Bottom Beater Assembly7-4
BS208140 - 1000RPM PTO	10-1
Deflector	8-18
Electric Actuator Option9-2
Fork8-4
Fork Lift Assembly	7-10
Front Chain Drive8-8
General Information1-1
General Safety2-1
Grease Points6-2
Hitch8-2
Hitch Assembly	7-11
Hydraulic Actuator Option9-3
Hydraulic Actuator Option Layout9-5
Hydraulic Flow	8-22
Hydraulic Layout	8-20
Hydraulic Safety2-3
Instructions3-1
ISO Safety Decal Illustrations3-5
ISO Safety Decal Locations3-3
Knife Kit Option9-1
Loading5-1
Maintenance Safety2-2
Model Decal Illustrations3-4
Preperation4-2
Processor Hydraulic Connection4-3
PTO Driveline4-2
Ram8-6
Rear Idler8-7
Repairs6-1
Safety Decal Illustrations3-2
Safety Decals Placement / Replacement3-1
Safety Terms and Symbols2-1
Serial Number Location1
Specifications1-1
Boss II Height1-1
Boss II Length1-1
Boss II Width1-1
Capacity1-1
Chamber Size1-1
Dual Hydraulics1-1
Maximum Flow Allowed1-1
Minimum Hydraulic Flow Required1-1
Power Unit Horsepower Required1-1
P.T.O.1-1

Tire Size1-1
Spreading Material5-1
Tire & Axle Assembly7-2
Transport Safety2-3
Upper Beater	8-16
Upper Beater Assembly7-6
Uses1-1
Using On Inclines5-1
Warranty and Limitation of Liability	I



Scan with smartphone to
download latest manual.

TUBE•LINE™