

TUBE•LINE™

Tubeline Manufacturing Limited
6455 Reid Woods Drive RR #4
Elmira, Ontario, Canada N3B 2Z3

Email: sales@tubeline.ca

Fax: 519.669.5808

Tel: 519.669.9488

Toll-free (North America): 1.888.856.6613

www.tubeline.ca

Operator's Manual

Keep this manual with the machine at all times.

TL60ECV

Balewrapper

TL60ECV

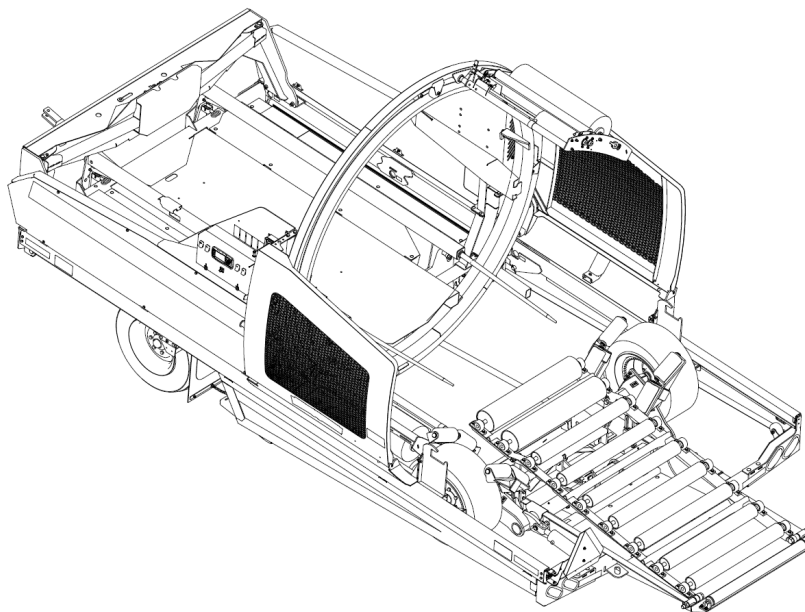

Do not attempt to operate this machine without thoroughly reviewing this manual for safe and proper operation.

Operator's Manual

Thank you for choosing the Tubeline TL60ECV Balewrapper. Our hope is that it will give you many years of productive service. This machine is designed to wrap bales in a continual line with plastic film. Please read and understand this manual and the machine before operating.

Advantages to High Moisture Hay

High moisture hay has many advantages over traditional dry hay.

High moisture hay provides:

- Lower harvesting time
- Cuts to feeding costs
- Increases ADG (Average Daily Gain)
- Minimizes storage loss
- Less reliance on favorable weather.

To learn more about this process visit <http://tubeline.ca/silage.php>

Advantages to Wrapping Bales

Using an in-line bale wrapper to protect your product provides a cost and time efficient means of bale storage and limits spoilage of bales.

Manuals

Parts manuals are printed and shipped with machines as they leave the manufacturer. Your machine may include parts or features not yet included in the initially shipped manual. The latest manual version can be found at www.tubeline.ca/support. Tubeline reserves the right to update and change manuals as seen fit. Dealers are informed of any pressing changes/ modifications. They can help you with any questions regarding replacement parts.

Serial Number

The implement serial number is located on the front left corner of the frame. (See below) This number helps us to track changes and improvements and must be mentioned when ordering parts or requesting service. For your convenience, a space has been provided inside the front cover of this manual to record the serial number, model number, purchase date, and dealer name.

Model No: _____

Serial No: _____

Date Purchased: _____

Dealer Name: _____

Engine Model No: _____

Engine Serial No: _____

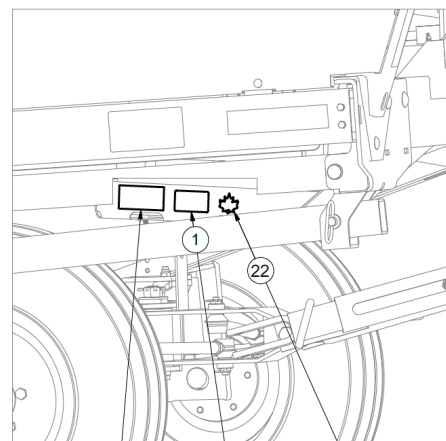



In-line Wrapper 3 Year Limited Warranty Statement *(Excludes Individual Wrapper)*

All Equipment is sold subject to mutual agreement that it is warranted by Tube-Line Manufacturing Ltd (hereinafter the company) to be free from defects in material and workmanship. The company's liability shall be limited exclusively to the original owner to replace or repair without charge, at its factory or elsewhere, at its discretion, any defects in material or workmanship which become apparent in the first year from the date on which the equipment was purchased. In the second and third year the company will supply at no charge replacement of defective parts only. Installation and freight will be at the expense of the owner.

Components supplied by third parties and not manufactured by the company will carry such warranty as extended by such parties, such as but not limited to, tires, batteries, electrical components, hydraulics and engines.

The buyer by the acceptance of the equipment will assume all liability for any damages which may result from accident, abuse or misuse by his employees or others. Any equipment that has been altered or modified without prior written authorization by the company will render the warranty null and void.

No employee or representative of the company is authorized to make changes to this warranty or grant additional warranty terms unless authorized in writing by management of the company.

The company shall not be liable for special, indirect or consequential damages of any kind including but not limited to, loss of revenue, rental replacement costs or other losses.

Normal wear and tear from normal use of the equipment is not warranted. The end user is expected to maintain and service the equipment in accordance with accepted practices. Failure to do so will void the terms of this warranty.

Warranty coverage is null and void unless Warranty Registration form has been completely filled in and is on file at Tube-Line Manufacturing Ltd.

Table of Contents

Operator's Manual	I
Advantages to High Moisture Hay	I
Advantages to Wrapping Bales	I
Serial Number	I
In-line Wrapper 3 Year Limited Warranty Statement (<i>Excludes Individual Wrapper</i>)	II
Section 1: General Information	1-1
Usage	1-1
Suitable Wrapping Timeframe	1-1
Bales	1-1
Wrapping Straw	1-1
Dimensions	1-1
Orientation	1-2
Terminology	1-2
Section 2: Safety	2-1
Safety Signal Words / Safety Messages	2-1
Safety Guidelines	2-1
Personal Protective Equipment	2-2
Lighting	2-2
Safety Decal Locations	2-4
Safety Decal Illustrations	2-5
Section 3: Setup	3-1
Dealer Installation	3-1
Battery Hookup	3-2
Pre-Operating Inspection	3-3
Manual Mode Test Run	3-3
Auto Mode Test Run	3-3
Wrapping Site	3-3
Section 4: Adjustments	4-1
Door Switch Adjustment	4-1
Plastic Film Installation	4-1
Bale Saddle Adjustment	4-4
Section 5: Control Panel Operation	5-1
Section 6: Control Screen Operation	6-1
General Button Functions	6-1
Auto Wrap Mode Screen Functions	6-1
Manual Wrap Mode Screen Functions	6-2
Control Screen Error Messages	6-2
Setup Screen	6-3
Information Screen	6-4
Parameters Screen	6-4

Section 7: Operation	7-1
Balewrapper Starting	7-1
Starting a Bale Row	7-1
Auto Wrap Mode	7-2
Steering	7-2
Stopping Cycle	7-2
Optional Remote Start	7-2
Ending Bale Row	7-3
After Wrapping	7-4
Section 8: Transporting Balewrapper	8-1
Transport Lock	8-1
Disconnect Battery	8-1
Fuel Shutoff - 13hp Engine Only	8-1
Power Unit Hookup	8-1
Slow Moving Vehicle (SMV) Sign	8-2
Observe Maximum Transport Speed	8-2
Tire Pressure	8-2
Storage	8-2
Section 9: Feeding	9-1
Feeding from Bale Row	9-1
Plastic Film Disposal	9-1
Section 10: Maintenance	10-1
Grease Points	10-1
Grease Timeline	10-2
Hydraulic Oil	10-2
Hydraulic Oil Filter	10-2
Section 11: Diagnostics	11-1
Manifold Solenoid Functions	11-1
Troubleshoot Plastic Film and Carriers	11-2
Section 12: Option - Power Drive	12-1
Power Drive Installation - Manifold	12-1
Power Drive Installation - Wiring	12-1
Power Drive Installation - Single	12-2
Power Drive Installation - Dual	12-3
Power Drive Operation	12-4
Section 13: Option - Remote Control	13-1
Remote Control Installation	13-1
Remote Control Operation	13-1
Section 14: Option - Plastic Film Sensor	14-1
Film Sensor Installation	14-1
Plastic Film Sensor Adjustment	14-1
Plastic Film Sensor Operation	14-2

Section 15: Option - Wireless Plastic Film Sensor	15-1
Wireless Film Sensor Receiver Board Installation	15-1
Wireless Film Sensor Transmitter Installation	15-2
Wireless Film Sensor Operation	15-2
Section 16: Option - Dispatch Arm	16-1
Dispatch Arm Installation	16-1
Dispatch Arm Operation	16-2
Section 17: Option - Guide Roller Kit	17-1
Guide Roller Kit Installation	17-1
Section 18: Option - Night Light Kit	18-1
Night Light Kit Installation	18-1
Night Light Kit Operation	18-1
Section 19: Option - Twin Wrap Kit	19-1
Twin Wrap Kit Installation	19-1
Twin Wrap Kit Adjustments	19-1
Twin Wrap Plastic Film	19-2
Section 20: Option - Laser Guidance System	20-1
Laser Guidance Installation	20-1
Laser Guidance Adjustment	20-2
Section 21: Option - Roadflex Suspension Axle	21-1
Suspension Axle Installation	21-1
Imperial Torque Value Chart	VII
Metric Torque Value Chart	VIII

Intentionally Left Blank

Section 1: General Information

Usage

This machine is designed to wrap round bales in a continual row with plastic film.

Suitable Wrapping Timeframe

Use a hard-core baler to make the well-shaped and firm bales necessary for successful wrapping. Bales are best wrapped as soon as possible after baling. If bales are left unwrapped they will sag and lose shape. Heating will start soon after baling and protein quality will be lost. It is desirable to wrap within four hours. In an emergency, the bales can be left 12 to 16 hours.

The Tubeline wrapper makes timely harvest possible by reducing the dependence on the weather. It is much easier to get to wilt silage than to make dry hay. This also extends the working day, as the correct moisture to bale extends earlier and later in the day.

For more information visit <http://tubeline.ca/silage.php>

Bales

The TL60ECV will wrap round bales **up to 6'**. It will wrap square bales **up to 6' wide**.

Wrapping Straw

Only two layers of plastic are necessary to weather-protect straw with the TL60ECV. Dry straw may be wrapped continually without spaces. Straw with moisture is best wrapped with spaces in the plastic.

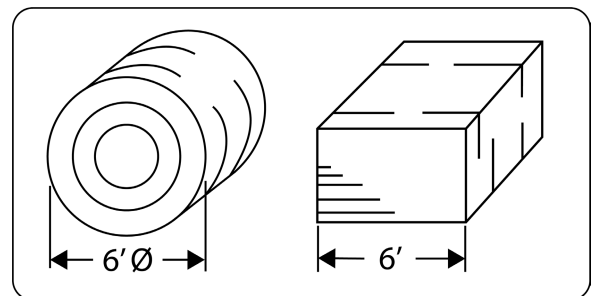

Dimensions

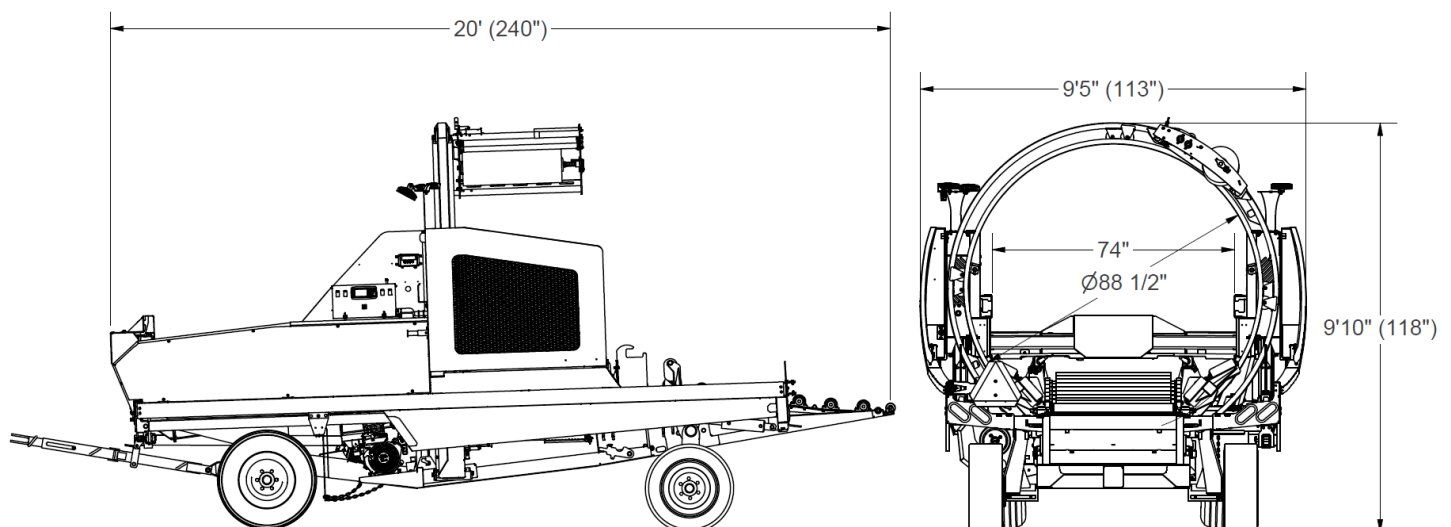

Orientation

Directional references in this manual are dependant on the operator's position from a forward pointed position while towing this machine.

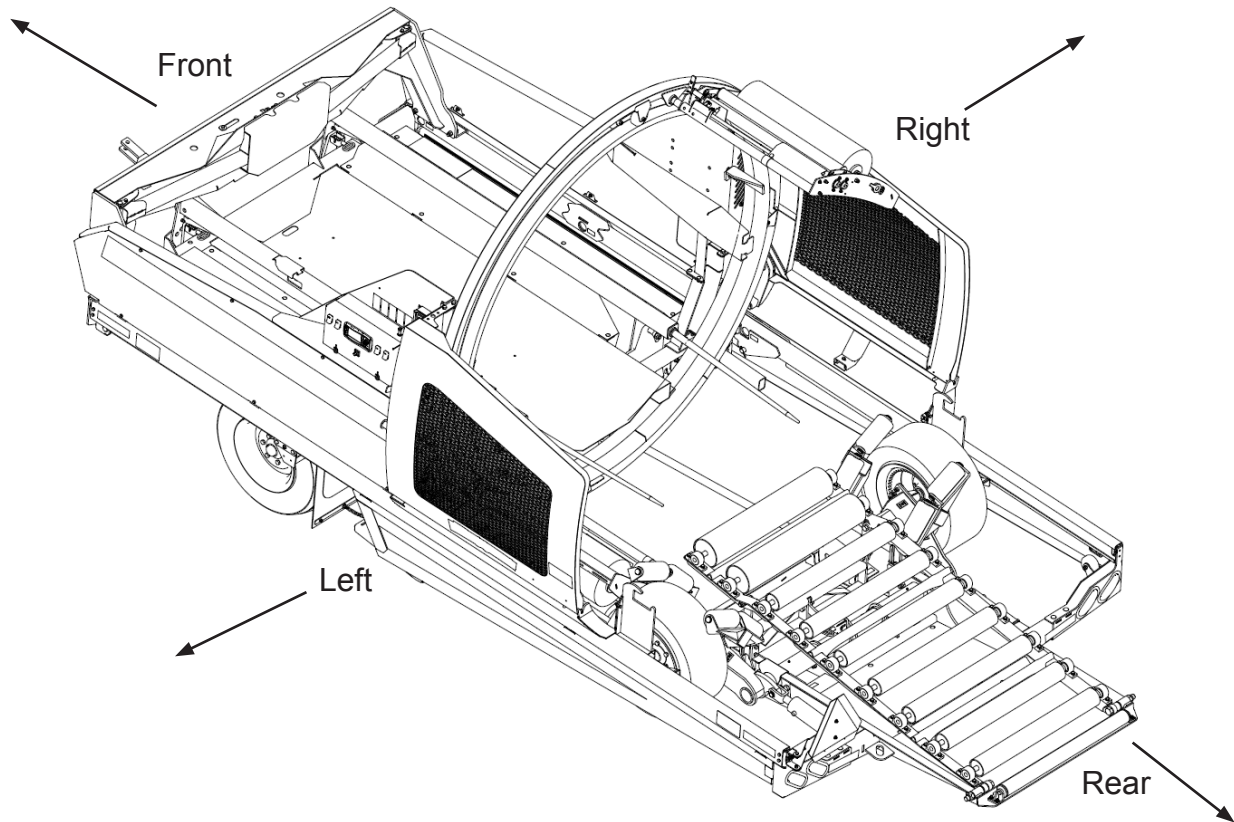

Terminology

Common terms used in this manual.

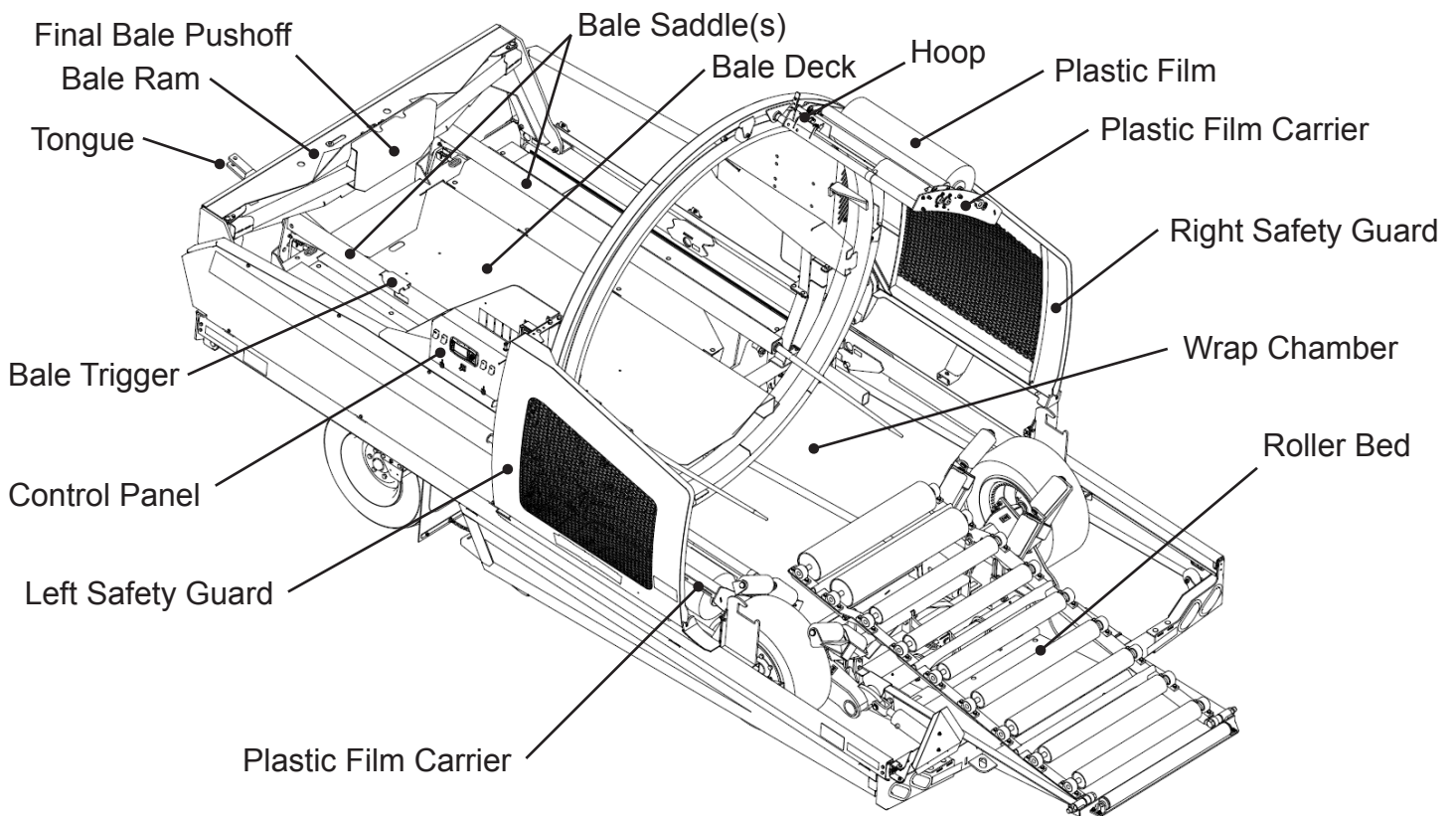

Section 2: Safety

NOTE: This safety alert symbol is found throughout this manual to call attention to instructions involving yourself and others working around the machine.

Failure to follow these instructions can result in injury or death.



This symbol means:

- **Attention!**
- **Become Alert!**
- **Your Safety is involved!**

Safety Signal Words / Safety Messages

CAUTION: Indicates a potentially hazardous situation that may result in injury.

WARNING: Indicates a potentially hazardous situation that could result in serious injury or death.

DANGER: Indicates a hazardous situation that needs to be avoided. Operator needs to be aware of these dangers. High probability of serious injury or death.

NOTE: Indicates an informative non-safety related message.

Safety Guidelines

Take the necessary precautions to avoid injury or death. These include:

- Have training and train new operators.
- Review the safety instructions with all users annually.
- Know where safety decals are and what they convey.
- **DO NOT** paint over, remove or deface any safety signs or warning decals on your equipment.
- Replace damaged and/or missing safety decals.
- **DO NOT** operate without fully installed shields.
- Reinstall any removed shields **BEFORE** operating.
- Inspect machine before operating.
- **DO NOT** operate this machine while under the influence of drugs or alcohol.
- **DO NOT** let children ride or operate this machine.

Personal Protective Equipment



WARNING: Wear work boots, gloves, and safety glasses when maintaining or repairing machine.

WARNING: Wear work boots and ear protection when operating machine.

DANGER: Do not wear loose clothing when operating or maintaining the TL50SLV.

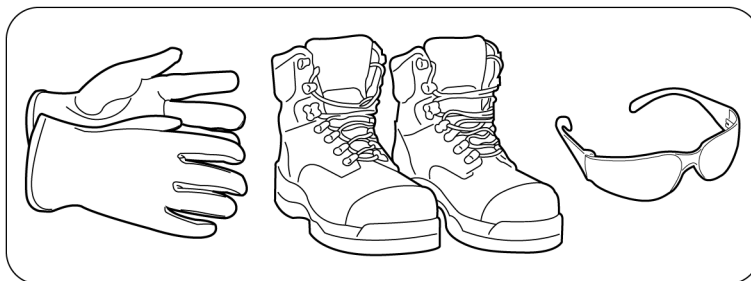

Lighting

This machine is equipped with lights and reflectors as required by the most stringent government and ASAE specifications. They connect to power unit's 7-pin receptacle.

7 Pin Connector Wiring:

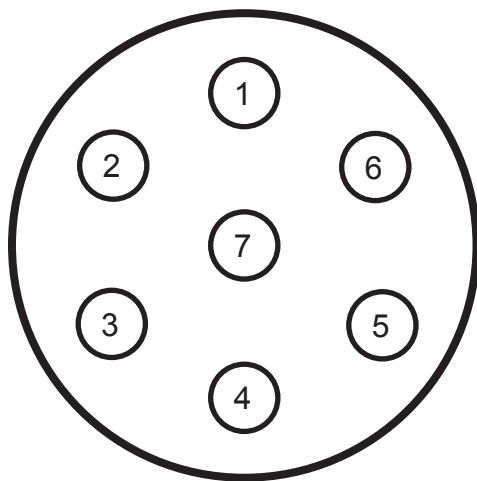

7-Pin Connector Front

PIN	WIRE	FUNCTION
1	White	Ground
2	N/A	N/A
3	Yellow	Amber Running Light / Left Turn
4	N/A	N/A
5	Green	Amber Running Light / Left Turn
6	Brown	Red Brake Lights
7	N/A	N/A

Clearance Markers

Part No: DEAMBER

Part No: DERED

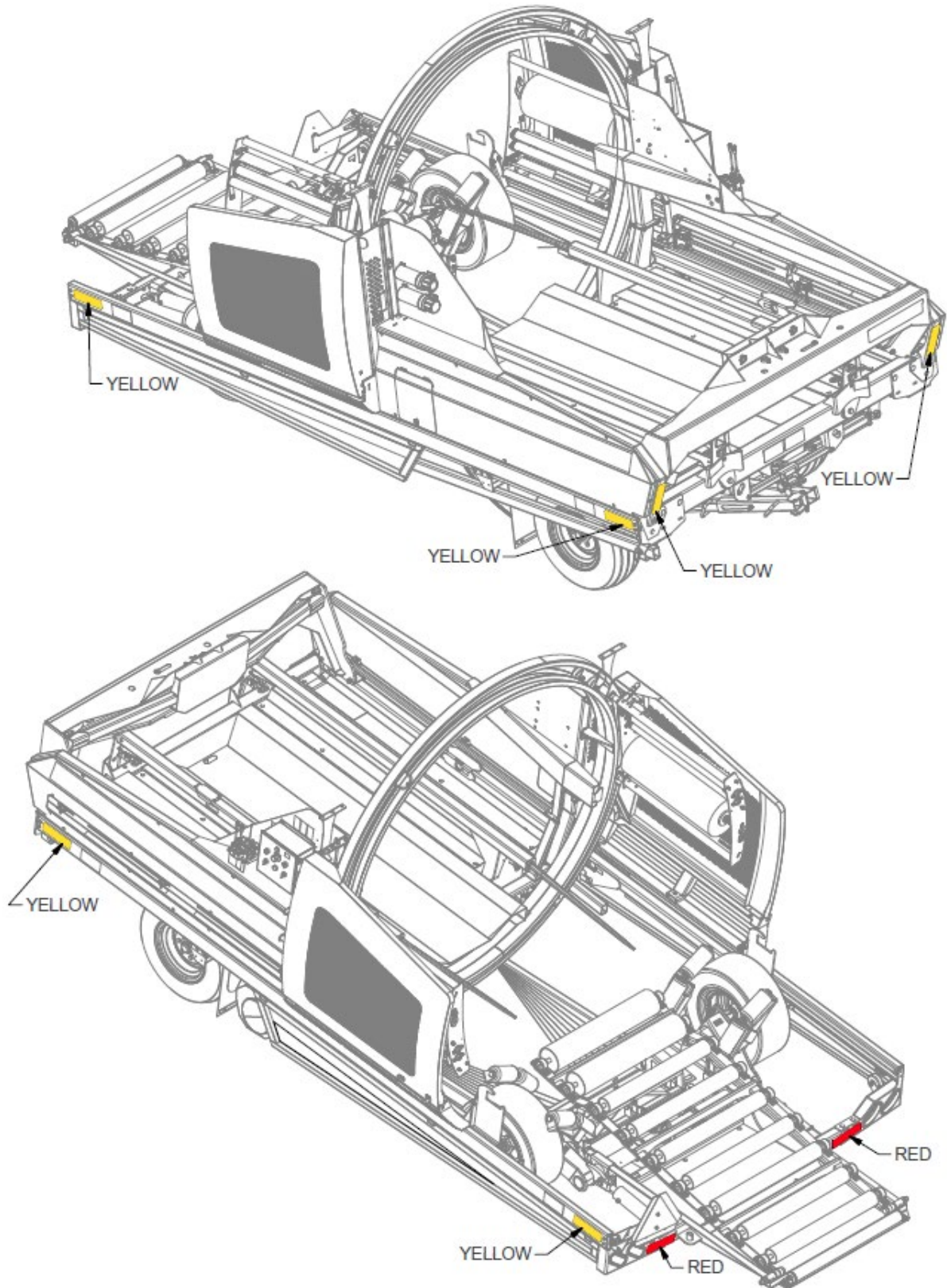
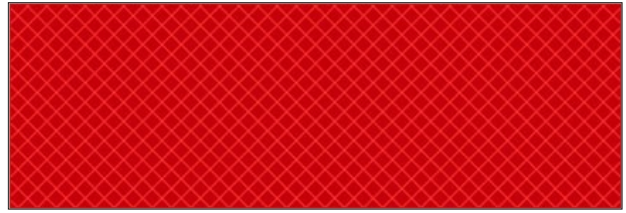
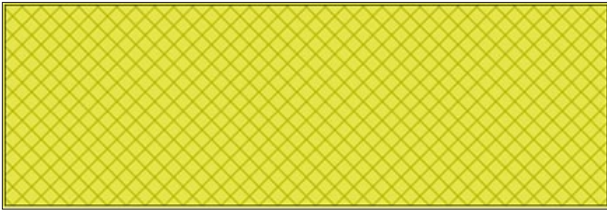

Safety Decal Locations

NOTE: Decals shown are not to scale.

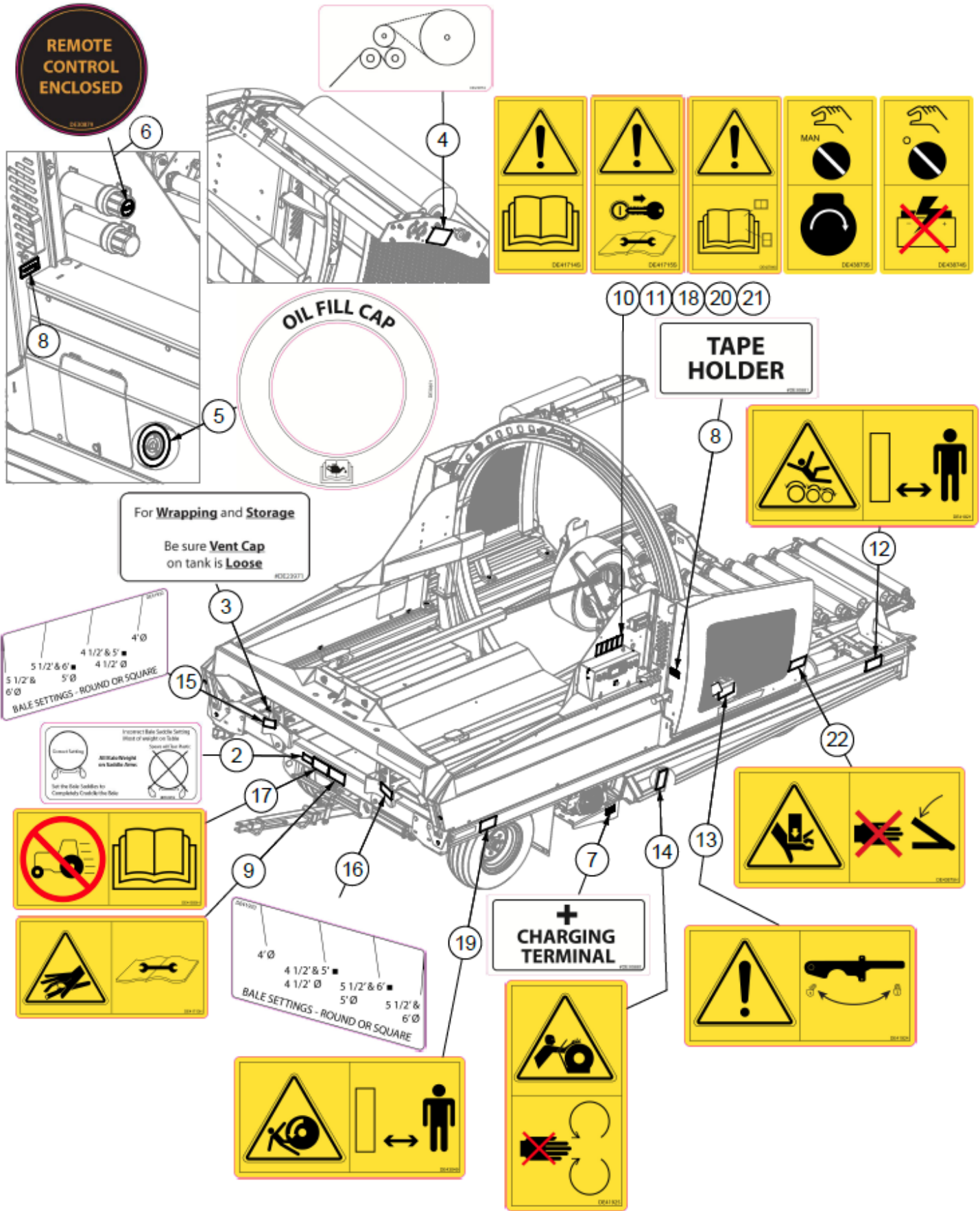

ITEM	QTY	PART NUMBER	DESCRIPTION
1	1	DE23941	Canada/USA Patent Decal
2	1	DE23959	Bale Settings Correct and Incorrect
3	1	DE23971	Wrapping and Storage Decal
4	2	DE23974	Wrap Instruction Decal
5	1	DE30871	Oil Fill Cap Decal
6	1	DE30879	Remote Control Decal
7	1	DE30880	Battery Boost Decal
8	2	DE30881	Tape Holder Decal
9	1	DE41713H	ISO Decal - High Pressure Fluid Horizontal
10	1	DE41714S	ISO Decal - Read Operator's Manual (50mm X 96mm)
11	1	DE41715S	ISO Decal - Remove Key Before Repair (50mm X 96mm)
12	2	DE41921	ISO Decal - Do Not Stand on Rollers
13	1	DE41924	ISO Decal - TL6000 Transport Lock Arm
14	1	DE41925	ISO Decal - Hoop Wheel Entanglement
15	1	DE41932	Right Bale Saddle Decal
16	1	DE41933	Left Bale Saddle Decal
17	1	DE41935H	ISO Decal - Transport Speed Limit
18	1	DE42784S	ISO Decal - Read OM Decal Section (50mm x 96mm)
19	2	DE43049	ISO Decal - Wheel Crush
20	1	DE43873S	ISO Decal - Engine Start in MAN
21	1	DE43874S	ISO Decal - Panel OFF Before Boosting
22	1	DE43875H	ISO Decal - Hand Crush
23	1	DECANADA	Decal Made In Canada

Safety Decal Illustrations

Part No: DE23941 Item: 1 (See [pg.1](#))

Canada, United States patent information decal.

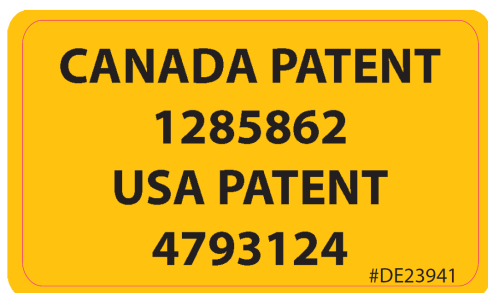

Part No: DE23959 Item: 2

Decal shows correct settings for bale saddles. This will vary with bale firmness, weight, size, etc.

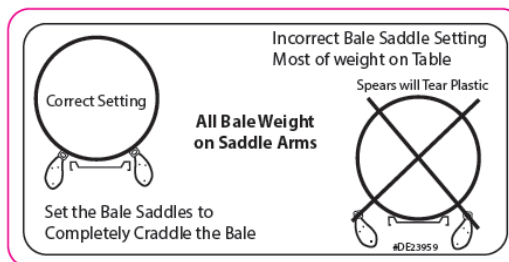

Part No: DE23971 Item: 3

Loosen vent cap on top of fuel tank to release any fume build-up.

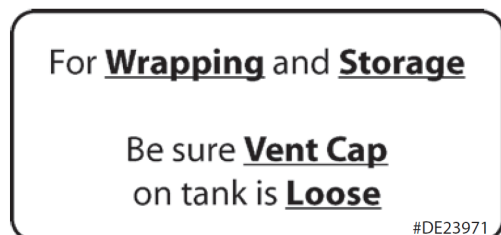

Part No: DE23974 Item: 4

Side view of proper plastic film routing through bale wrap carrier.

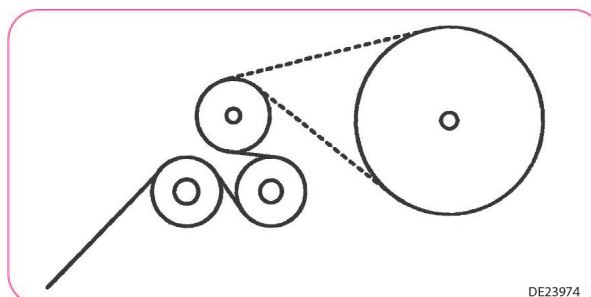

Safety Decal Illustrations

Part No: DE30879 Item: 6

Remote Control Enclosed decal.



Part No: DE30881 Item: 8

Wrap tape can be stored on this holder.



Part No: DE30880 Item: 7

Positive charging terminal for use a battery boost.



Part No: DE41714S Item: 10

Read this manual and learn the machine functions before attempting to wrap bales.

Part No: DE41715S Item: 11

Read this service manual before attempting repairs, remove key from engine before attempting repairs.

Part No: DE41713H Item: 9

Do not use hand to check for hydraulic leaks, alternatively use a piece of cardboard.

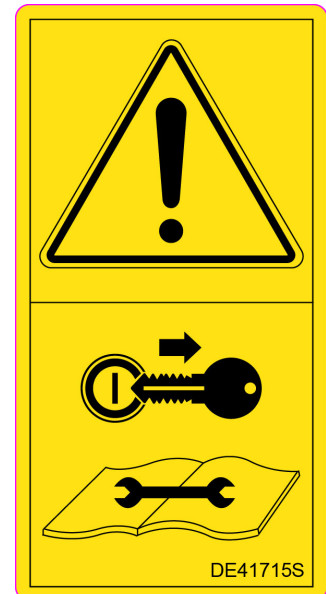
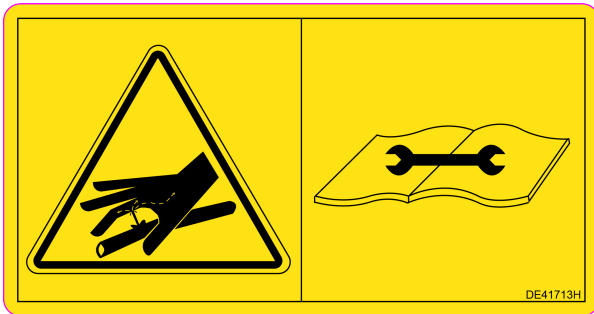

Part No: DE41921 Item: 12

Do not stand on rollers, stand clear of machine while in operation. Use caution when attempting repairs in this area.

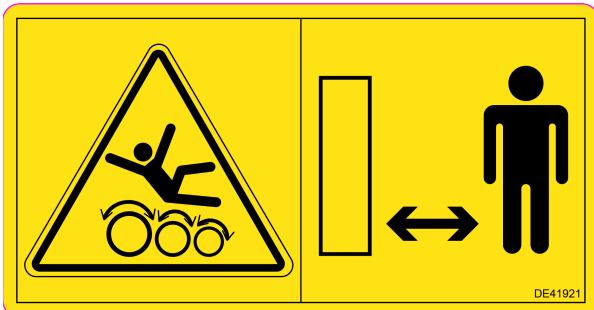

Safety Decal Illustrations

Part No: DE41924 Item: 13

Remove pin before unlocking transport lock arm. Raise rear cam axle to allow transport lock to move to desired position.

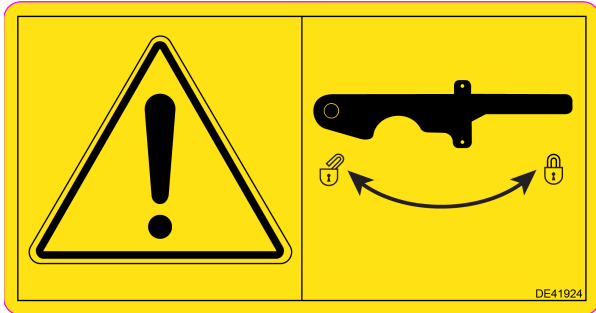

Part No: DE41925 Item: 14

Entanglement hazard, do not remove wheel drive shield while engine running.



Part No: DE41932 Item: 15

Left side Bale Saddle settings decal. Align outer edge of bale saddle with desired bale size as shown on decal.

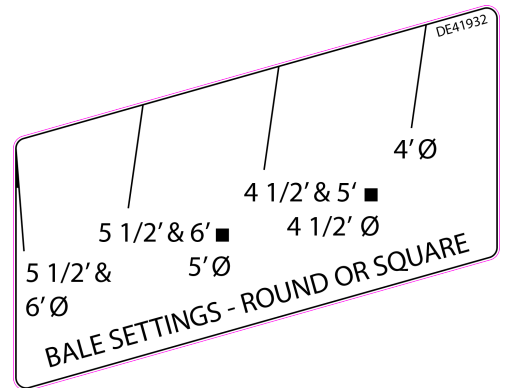

Part No: DE41933 Item: 16

Right side Bale Saddle settings decal. Align outer edge of bale saddle with desired bale size as shown on decal.

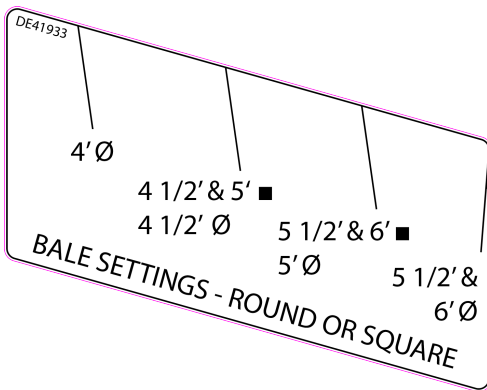

Part No: DE42784S Item: 18

Read the decal section of the operator's manual to understand potential hazards to avoid.

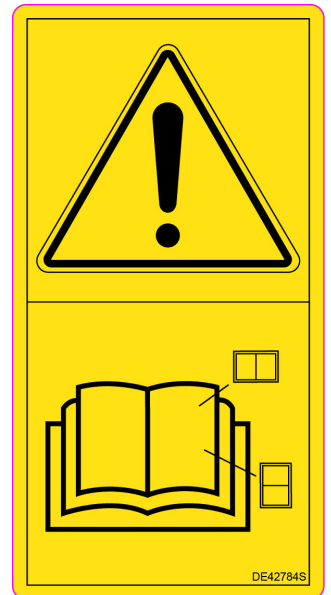

Part No: DE41935H Item: 17

Do not exceed top speed of 32km/h (20mph) while transporting this machine.

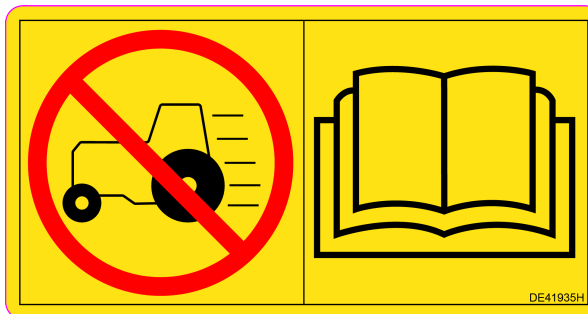

Part No: DE43049 Item: 19

Keep clear of wheels when machine in operation and transportation.

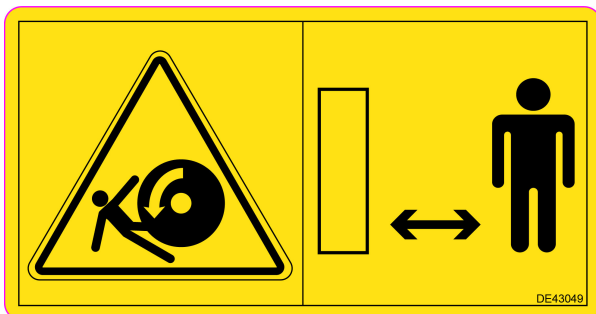

Part No: DE43873S Item: 20

Turn control panel to manual wrap mode (MAN) before starting engine.

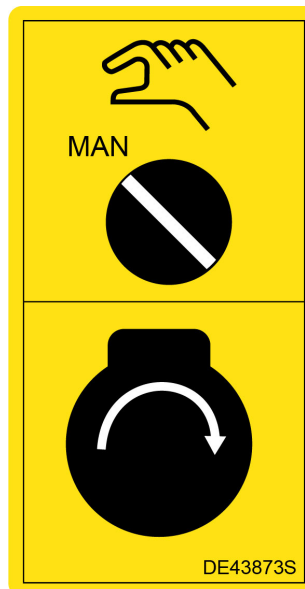

Safety Decal Illustrations

Part No: DE43874S Item: 21

Turn off engine power and control panel before boosting battery.

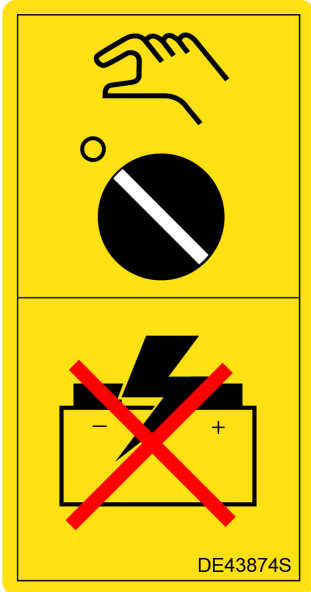

Part No: DE43875H Item: 22

Use handle when lowering pivoting safety guard to avoid pinching or crushing hands.



Part No: DECANADA
Item: 23 (See [pg.1](#))

Manufacturer of origin decal.



Section 3: Setup

Dealer Installation

Upon delivery the following parts will need to be installed to make the TL60ECV field ready:

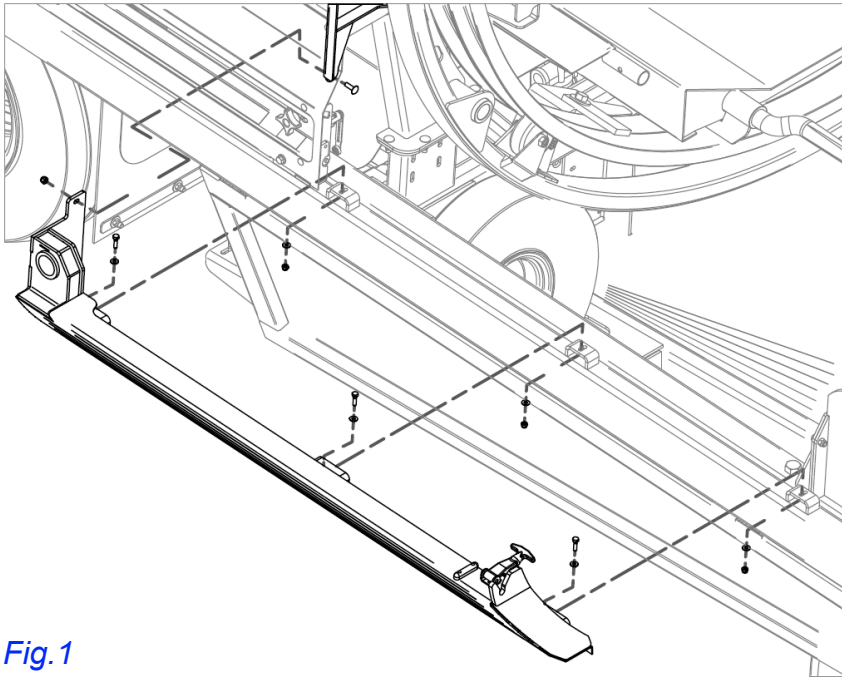

Fig. 1

1. Refer to [Parts Manual](#) to ensure all hardware and parts have been delivered.
2. Remove all banded parts from either bale deck or roller bed.
3. Install bottom safety guard mounts using bolts, washers and nuts. Left side shown in [Fig. 1](#), right side is the same.

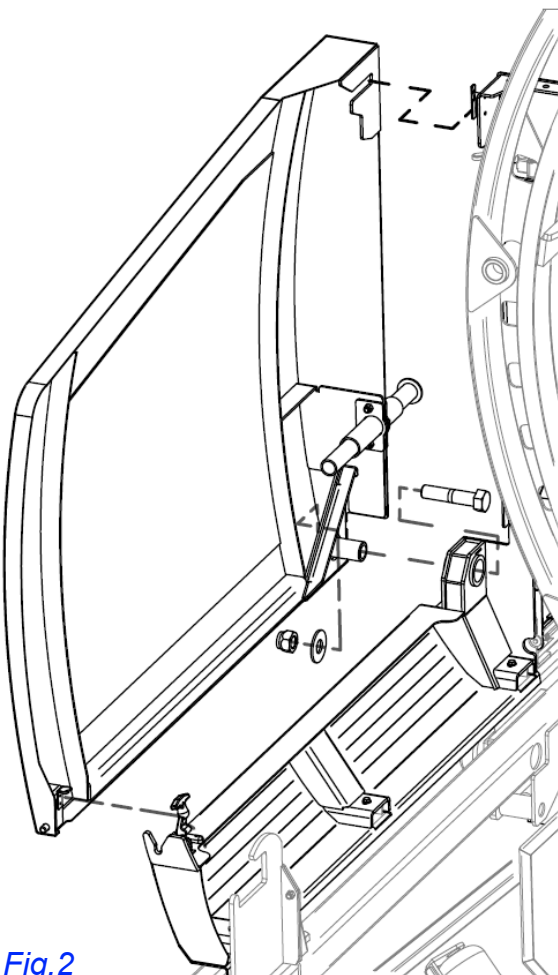

Fig. 2

4. Install left safety guard by bolting at pivot point. Do not over tighten. See [Fig. 2](#).
5. Close pivoting left safety guard top slot over safety guard mount hook.
6. Check left safety guard range of motion.
7. Lock rubber latch at rear of safety guard.
8. Ensure door switch contacts left safety guard when in closed position. Refer to [Adjustments, pg. 4-1](#).

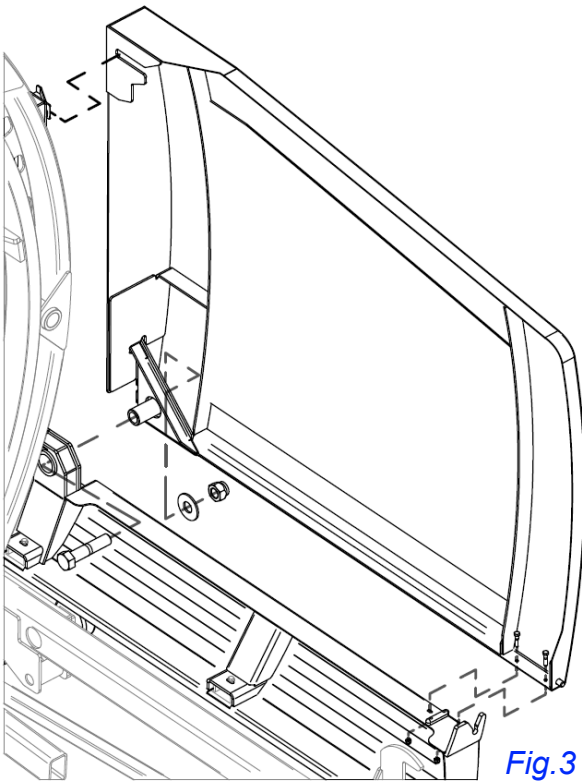

Fig.3

9. Install right maintenance safety guard by bolting at pivot point. Do not over tighten. See [Fig.3](#).
10. Close right maintenance safety guard top slot over safety guard mount hook.
11. Bolt rear of safety guard with bolts and lock nuts.
12. Install Dispatch Arm option, if applicable. Refer to [pg.15-2](#).

Battery Hookup



Fig.1

TL60ECV bale wrappers are shipped with the battery disconnected for safety reasons.

1. Locate battery at middle right of balewrapper. See [Fig.1](#).
2. Reconnect by simply bolting unhooked positive (+) red cable to its matching battery terminal (**A**).
3. Confirm TL60ECV's functions are working properly. Refer to **Control Screen Operations**, [pg.6-1](#).

Pre-Operating Inspection

Before wrapping at a new site:

- Check oil tank level. Leave about 1/4” from top of sight guage when filling to avoid overflow.
- Check gas tank level.
- Check Tire Pressure.
- Complete a walk around inspection.
- Check engine for hazardous flammable material buildup.
- Check guarding is secure.

Manual Mode Test Run

Test machine in Manual wrap mode without bales and without plastic film rolls installed.

1. Start engine, refer to **Balewrapper Starting**, [pg.7-1](#).
2. Turn on control panel, refer to [pg.5-1](#).
3. Advance bale ram towards hoop chamber by turning FWD-REV control panel switch to **REV**.
4. While holding bale ram switch in **REV**, engage Hoop Rotate button to test hoop rotation speed.
5. Release REV bale ram switch and Hoop Rotate when bale ram reaches fully extended position.
6. Return the bale ram to front of bale wrapper (“Home” position) by turning **FWD-REV** bale ram switch to **FWD** (forward).

Auto Mode Test Run

Test machine in Auto mode without bales and without plastic film rolls installed.

1. Switch control screen to auto mode, refer to [pg.6-1](#).
2. Press the bale trigger using a pole inserted between the bale ram and the bale deck.



DANGER: DO NOT attempt to engage the bale trigger by hand.

3. The TL60ECV balewrapper should automatically follow the sequence of the manual wrap mode without the manual operation of the control screen.

Wrapping Site

- Select a site that will allow room to make an adequate bale row length.
- Site should be free of grass and debris which can attract rodents that damage plastic film.
- There should be space for at least 50 bales in a row.
- Select a site that is accessible in winter conditions and does not flood in the spring.
- Avoid soft ground, as the wrapper will not move forward smoothly if it is sinking into the ground.
- Operate on level ground or a slight uphill grade for best bale row compaction.

Section 4: Adjustments

Door Switch Adjustment

Fig.1

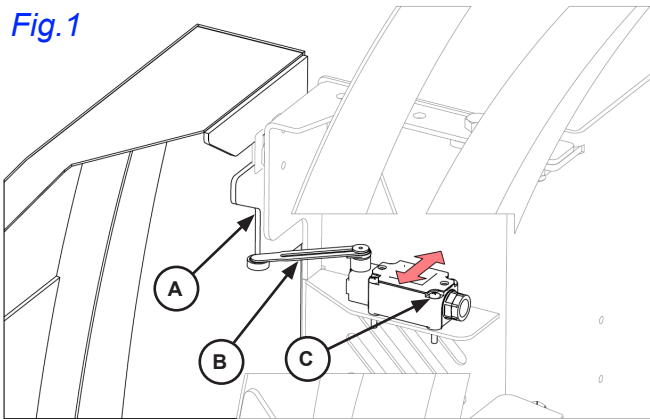

Top tab (A) of left safety guard must be fully closed and contact the door switch arm (B) to engage auto wrap mode. See [Fig.1](#).

- Loosen 4 machine screws (C) and slide door switch forwards if door switch does not contact left safety guard tab.

Loosen 4 machine screws (C) and slide door switch towards rear of machine if door switch arm contacts safety guard tab before safety guard is fully lowered.



Plastic Film Installation

DANGER: Switch control panel to manual wrap mode before changing plastic rolls. Never leave it in auto wrap mode as cooperators may set a new bale on the table or engage wrap cycle with remote.

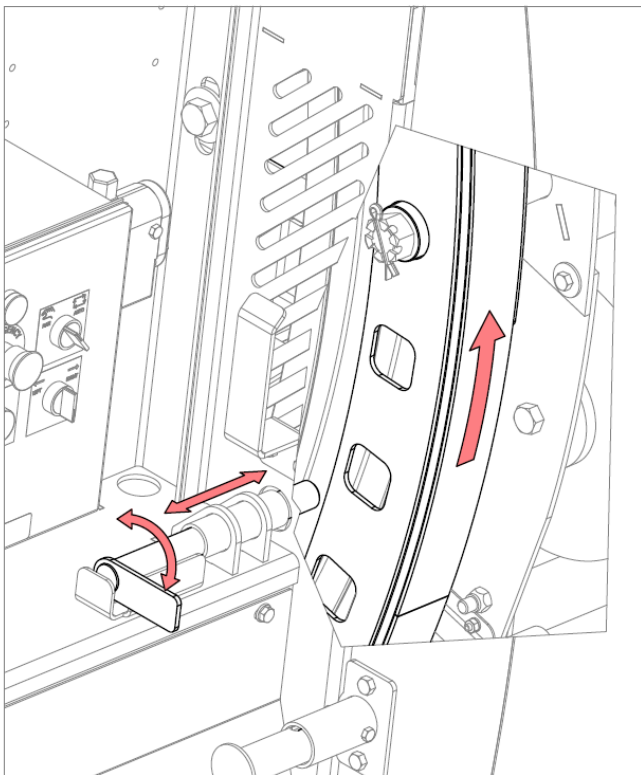

Fig.1

Plastic has a natural tack. In the event of the plastic being stored for an extended period of time the tack may migrate to the opposite side. To test for tacky fold plastic inside to inside and pull apart. Fold opposite way (top to top) to determine tackier side.

The roll of plastic should be installed with the tack against the bales.

The two metal stretcher rolls rotate at different speeds. This causes the plastic to be stretched. Plastic goes over the slow roller first and faster roll second.

1. Rotate hoop manually until empty plastic wrap carrier can be accessed from the left safety guard position. See [Fig.1](#).
2. Lift handle and insert hoop lock pin through hole in hoop to lock plastic wrap carrier to desired height. See [Fig.1](#).

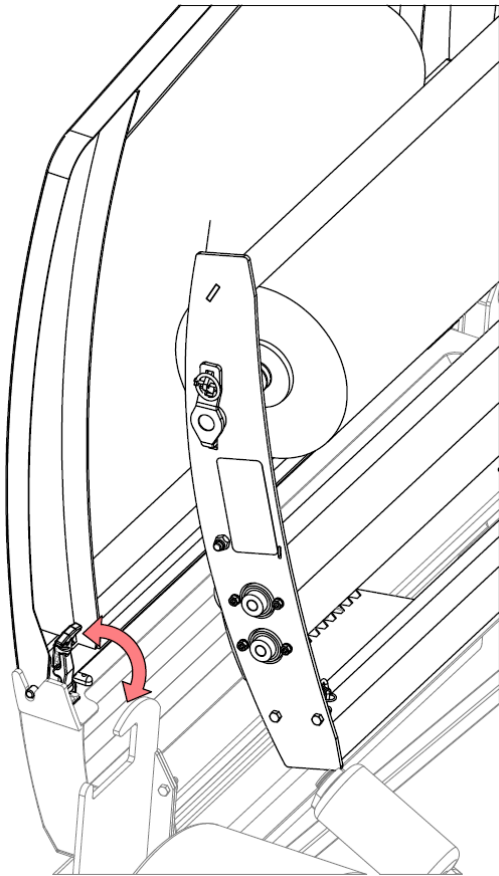

Fig.2

3. Unfasten rubber latch from inner rear of left safety guard. See [Fig.2](#).

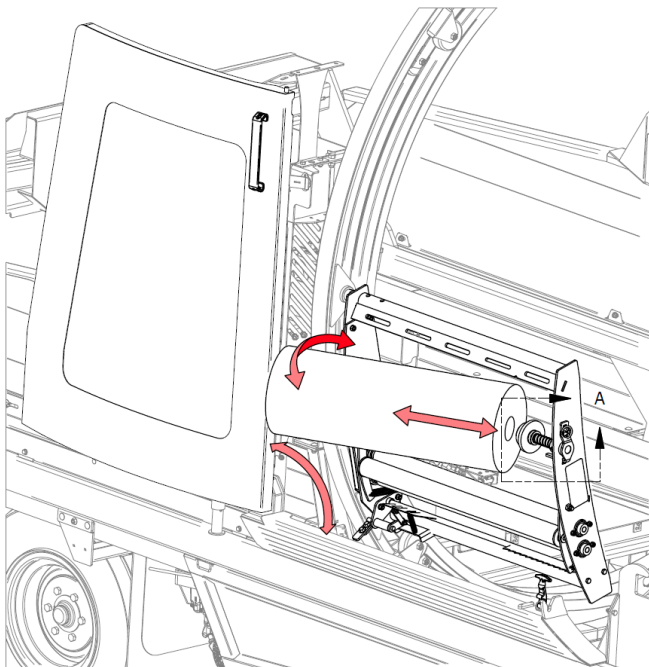
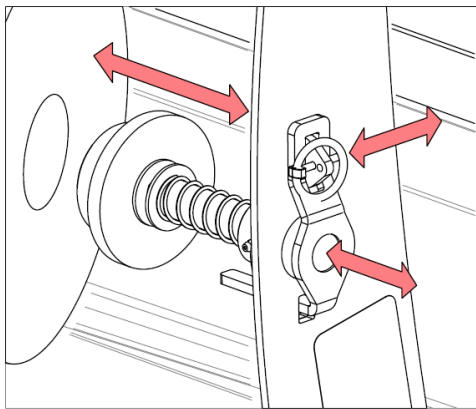

Fig.3

4. Lift left safety guard 90° to open position. See [Fig.3](#).
5. Remove linchpin from rear of plastic wrap carrier. See [Fig.4](#).
6. Remove empty plastic wrap cartridge from plastic wrap carrier by compressing sliding spring spool.
7. Press one end of new plastic wrap roll into sliding spring spool. See [Fig.3](#).
8. Swing free end of plastic wrap roll into plastic wrap carrier, aligning hole over stationary spool.
9. Once aligned the sliding spring spool should snap into locked position.



DETAIL A

Fig. 4

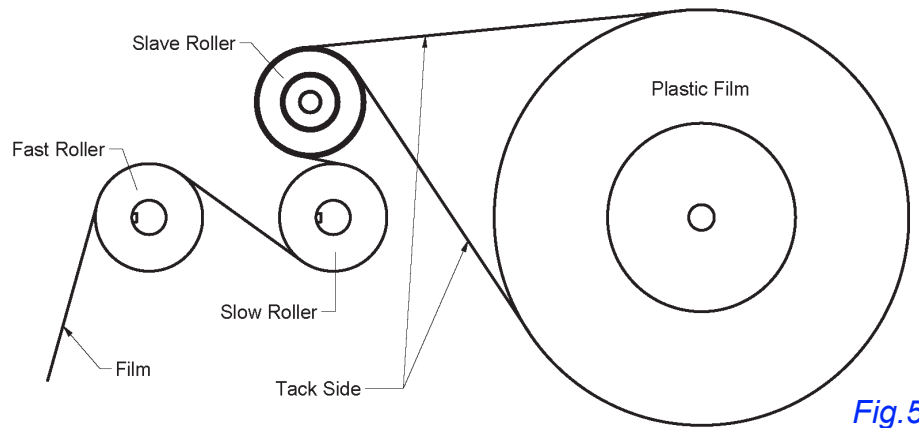

Fig. 5

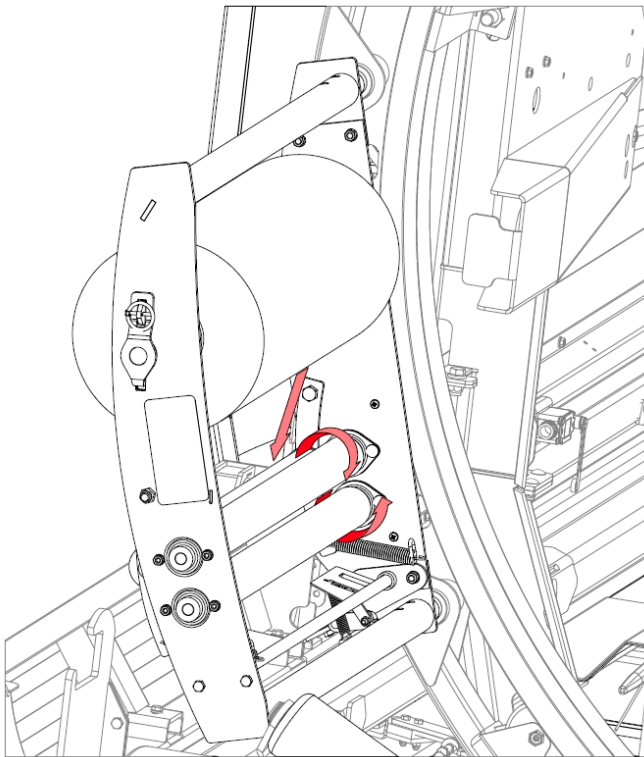

Fig. 6

10. Reinsert linchpin through sliding spring spool to secure new plastic wrap roll.
 11. Slide hoop lock pin out of hoop to resume wrap operation. See [Fig. 1](#).
 12. Route loose end of plastic wrap roll through 3 bottom rollers as shown in [Fig. 6](#) and decal located on rear side of plastic wrap carrier. See [Fig. 5](#).
 13. Tie loose end of plastic to bale guide hook.
 14. Close left safety guard, secure with rubber latch.
- NOTE:** Rotate hoop and repeat steps 1-14 if other plastic wrap carrier requires reloading.

Bale Saddle Adjustment

The TL60ECV has moveable bale saddles to allow various bale sizes to be wrapped.

To adjust the bale size:

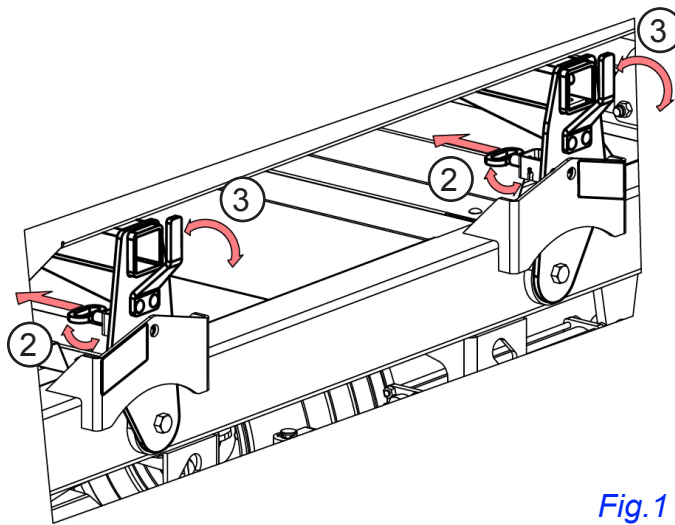

1. Look at decals on front of wrapper for bale saddle position. See [Fig.2](#).

NOTE: Bale sizes and positions on decals are a reference only. Bales may differ from recommended position due to baler settings, firmness, weight, etc.

2. Pull pin out and rotate clockwise to lock in open position. See [Fig.1](#).

3. Use handle to move bale saddle to desired position, aligning outside edge of bale saddle front plate with line on decal.

[Fig.1](#)

4. Rotate pin counter clockwise to lock pin and bale saddle.

5. Repeat for both saddles

6. Ensure bale saddle is locked in position before loading bales.

NOTE: Bale saddles should fully support bale. Round bales should not drag on bale deck.

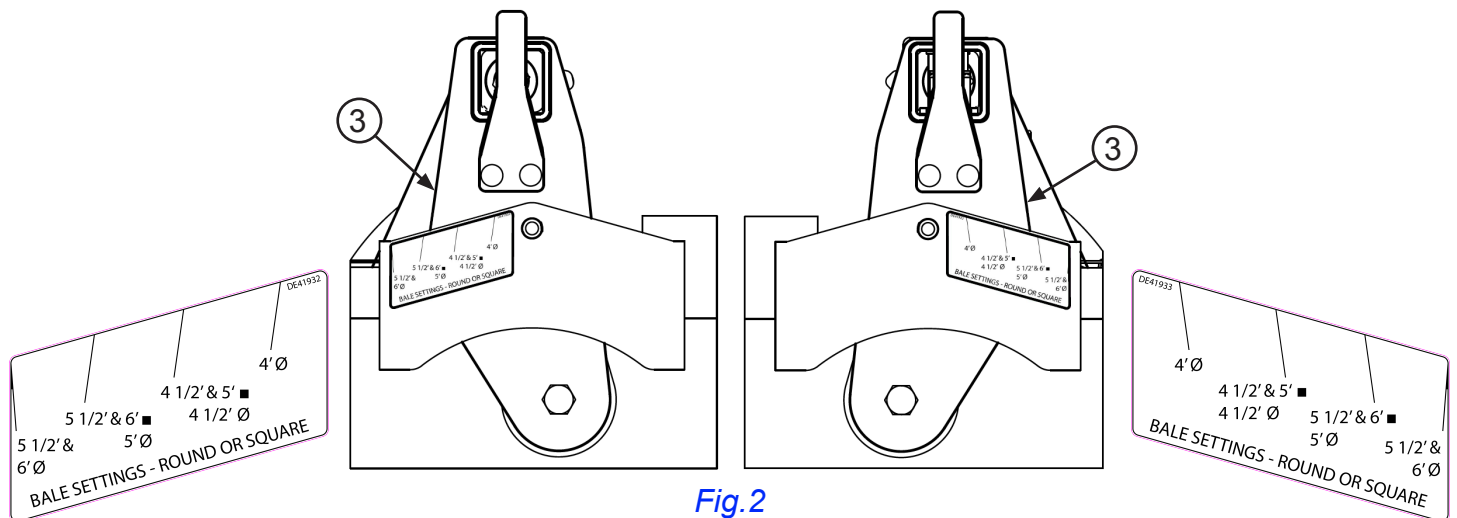

[Fig.2](#)

NOTE: On bale saddle decals, “Ø” represents round bale diameter, “■” indicates square bale size.

Section 5: Control Panel Operation

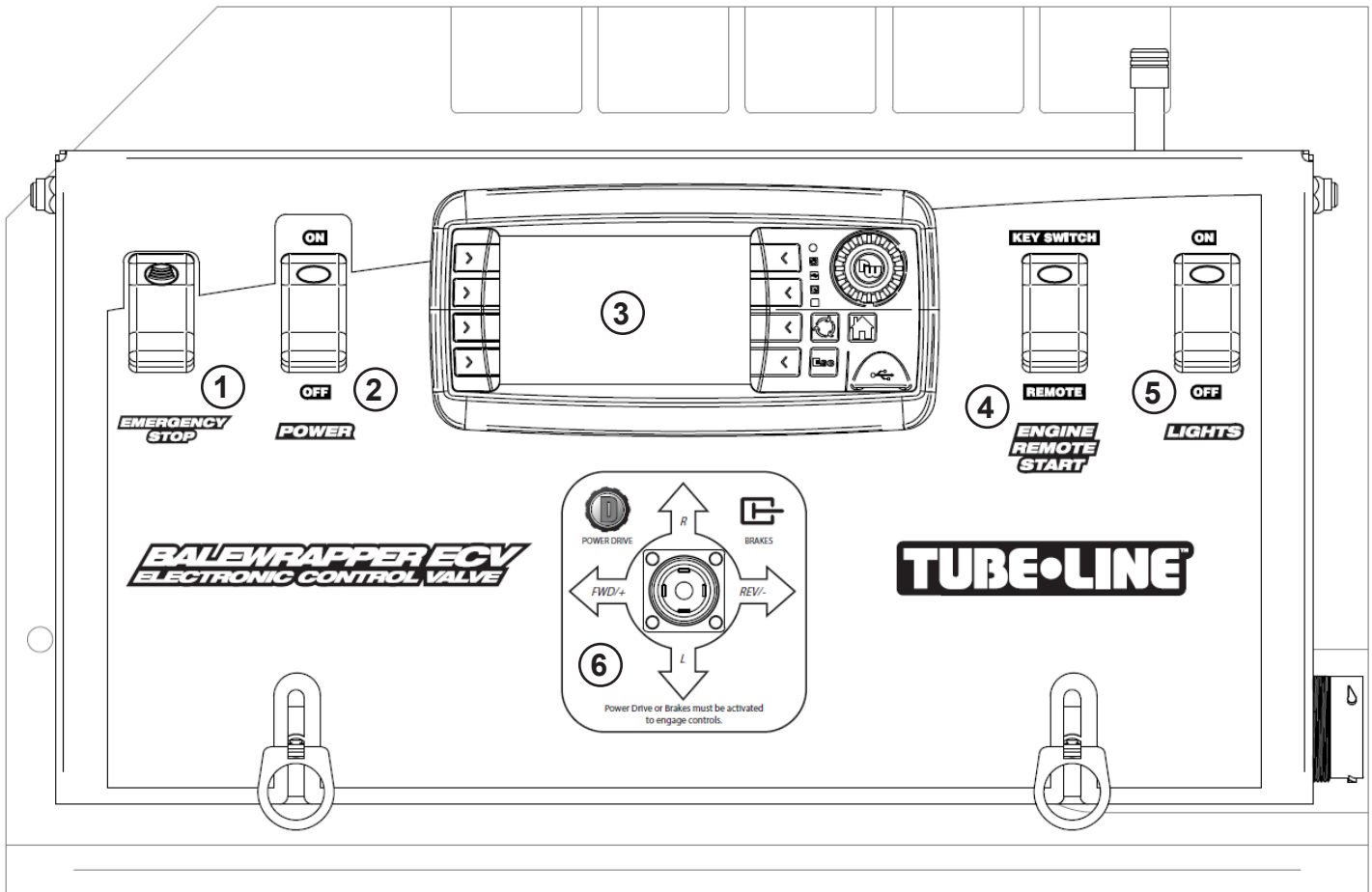

1. Emergency Stop Lockable Rocker Switch - Toggling this switch will shutdown all machine functions. Must be toggled down before restarting machine.
2. Power Rocker Switch - Turns control panel ON and OFF. Does not require engine to be running.
3. Control Screen - Main control screen for most bale wrapping operations. See [Section 6](#).
4. Engine Remote Start Rocker Switch - Default set to Key Switch. Toggle switch to Remote if bale wrapper is equipped with an optional remote control when desired. Refer to [Section 13](#) for further details.
5. Lights Rocker Switch - Simple ON/OFF function if machine is equipped with an optional night wrap light kit, [Section 18](#).
6. Powerdrive Joystick - If machine is equipped with a powerdrive option, this 4 position joystick enables steering of the machine from the control panel. Move joystick up to steer left, down to steer right, towards the front of balewrapper to drive forward or vise versa to reverse machine. See [pg.12-4](#).

Section 6: Control Screen Operation

After the machine is started (see **Balewrapper Starting**, [pg.7-1](#)) and the control panel screen is on you should see either a manual or automatic screen. The following screens show the different functions of the TL60ECV.

NOTE: Functionality will vary with different optional features.

NOTE: Illustrations may vary slightly from actual screens.

General Button Functions



1. Mode Button - Press to return to activated mode screen.
2. Back Button - Press to return to previous screen.
3. Next Button - Press once for Setup screen, twice for Information screen, and three times for Parameters screen.
4. Selector Knob - Turn to move to different selection, press to select a box for edit. Rotate knob to modify value of selected box. Press again to set value and deselect box.

Auto Wrap Mode Screen Functions



1. Wrap Mode Function - Press to switch to Manual Wrap mode.
2. Auto Wrap Enable Button - Press to enable the Bale Trigger after entering Auto Wrap Mode. If cycle has been stopped before completion, press again to resume the Auto Wrap cycle.
3. Wrap Cycle Pause Button - Press to pause an in-progress Auto Wrap cycle.
4. Roller Bed Up - Press and hold to raise rear roller bed to full height.
5. Roller Bed Down Button - Press and hold to lower rear roller bed to ground.
6. Laser Clearance Status - Displays actual distance from guiding bale row with laser guidance option. See [Section 20](#).
7. Laser Steering Status - Displays direction of optional laser guided steering. See [Section 20](#).
8. Brake Button - Not applicable with model TL60ECV.

Manual Wrap Mode Screen Functions

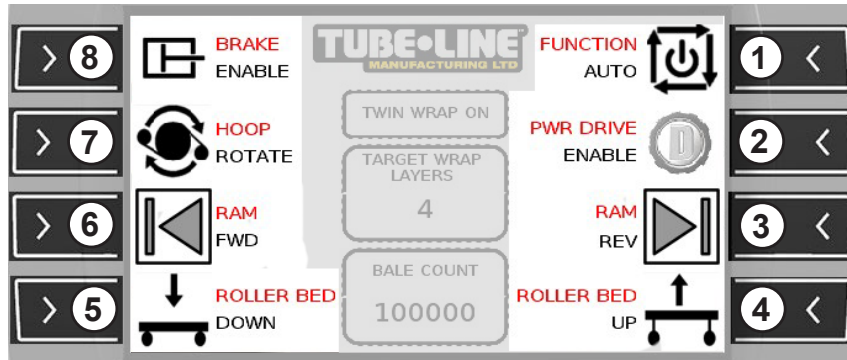

1. Wrap Mode Function - Press to switch to Auto Wrap mode.
2. Powerdrive Enable Button - Press to enable optional Powerdrive. Use control panel knob to complete desired drive operation. See Section ?? for more information.
3. Ram Reverse Button - Press and hold to push bale through wrap chamber.
4. Roller Bed Up - Press and hold to raise rear roller bed to full height.
5. Roller Bed Down Button - Press and hold to lower rear roller bed to ground.
6. Ram Forward Button - Press and hold to retract bale ram to front of machine.
7. Hoop Rotate Button - Press and hold with Ram Reverse Button to wrap bales manually.
8. Brake Button - Not applicable with model TL60ECV.

Control Screen Error Messages

If, while operating, you see an error message replacing the Tubeline decal, stop the machine and check that the doors are fully closed and that the film has not ripped or emptied.



Setup Screen

Press Next Button once to display the Setup screen. See **General Button Functions**, [pg.6-1](#).

SETUP			
TWIN WRAP 1	NO	60	AUTO WRAP BALE WIDTH [IN] 10
TARGET WRAP LAYERS 2	10	42	AUTO WRAP BALE OPENING [IN] 9
FILM SENSOR 3	ENABLED	6	AUTO HOOP START DELAY [IN] 8
ENABLE TIMER [s] 4	10	0	BALE COUNT ADJUST 7
LASER STEERING 5	LEFT	42 (40 in ACTUAL)	TARGET LASER DISTANCE [IN] 6

In the setup screen you may change settings to customize the wrapping operation. Use the selector knob to select and modify values.

1. Switch Twin Wrap box to “YES” if you have installed this option (4 rolls instead of normal 2).
2. Target Wrap Layers : Change amount from 2-20 layers per bale.
3. Enable/Disable the film sensor option as needed, see [pg.14-1](#).
4. Adjust time before power drive option auto disengages. Default is 10 seconds.
5. Turn off or change facing direction of laser guidance option if equipped, refer to [pg.20-3](#).
6. Change desired distance between bale rows if balewrapper equipped with optional laser guidance.
7. Set Bale Count Adjust to zero at start of new job.
8. Change to different length the ram will travel before the hoop starts rotating (default is 6”).
9. Change to different complete ram travel length (default is 42”).
10. Change to different preset bale widths (36”,48”,60”).

Information Screen

This screen is used as a diagnostic tool, it is not adjustable. Press Next button twice from activated Wrap Mode to display it.

INFORMATION			
TOTAL BALES MACHINE LIFETIME	150	CLOSED	LEFT DOOR
ECU VERSION	REV T, 32117	CLOSED	RIGHT DOOR
DISPLAY VERSION	REV 2, 032117	BALE NOT DETECTED	BALE IN SWITCH
REMOTE STEER LEFT	INACTIVE	FILM NOT DETECTED	FILM SENSOR
REMOTE STEER RIGHT	INACTIVE	RAM NOT HOME	RAM HOME SWITCH
REMOTE CONTROL AUTO	INACTIVE	120	HOOP PRESSURE [psi]
REMOTE CONTROL MANUAL	ACTIVE	250	JOYSTICK X [mV]
RAM POSITION [IN]	24.5	250	JOYSTICK Y [mV]
LASER SENSOR [mA]	18		

Parameters Screen

PARAMETERS			
WARNING! DO NOT CHANGE VALUES WITHOUT AUTHORIZATION			
WRAP WIDTH [INCHES]	27.0	100	HOOP SPEED OVERRIDE [%]
WRAP RATIO ADJUST [%]	100	24.5	RAM POSITION [INCHES]
PWR DRIVE ①	DISABLED	12	ACTUAL LAYERS PREVIOUS BALE
BRAKE	DISABLED		
LASER SENSOR ②	ENABLED		
ENGINE SIZE	13 HP		RESET TO DEFAULT

From activated Wrap Mode screen press Next button three times to reach the Parameters screen. This screen is used to enable/disable installed options. Non-labelled boxes are informative only. Use selector knob to select and modify installed options.

NOTE: Do not change settings without authorization from Tubeline Mfg.

1. Power Drive - Enable or disable.
2. Laser Guidance Sensor - Enable or disable.

Section 7: Operation

Balewrapper Starting

Fig.1 20hp shown.

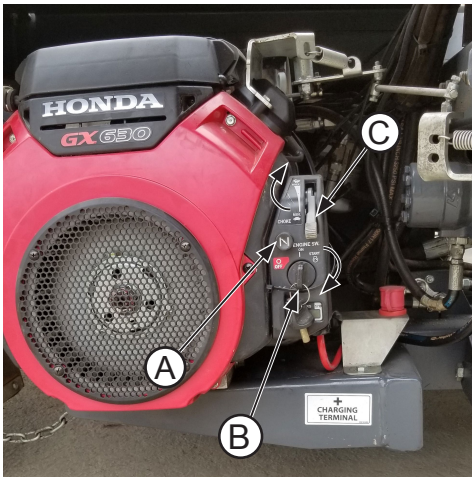

1. Read engine manual to familiarize yourself with its functions.
2. Choke (A) engine if cold starting.
3. Turn engine key (B) to START until engine runs. Do not hold more than 5 seconds.
4. Slowly throttle (C) engine as it warms up.
5. Switch control panel on and select manual wrap mode, refer to [pg.5-1](#).

Starting a Bale Row

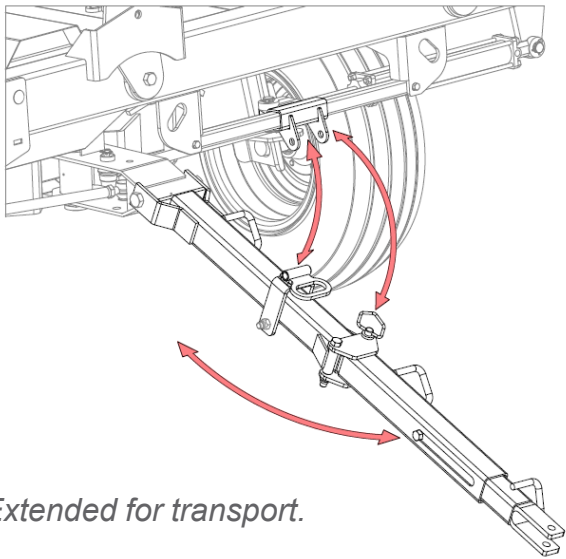

Extended for transport.

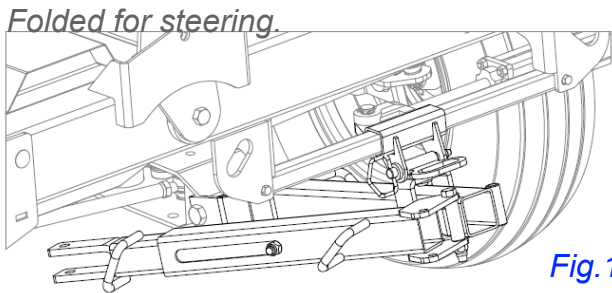

Folded for steering.

Fig.1

1. Place wrapper at start of desired row.
1. Disengage transport lock, see [pg.8-1](#).
2. Raise rear roller bed using control screen. Refer to [pg.6-1](#).
3. Fold tongue and pin to steering slider tube. See [Fig.1](#).
4. Confirm balewrapper is steering straight.
5. Place several unwrapped bales at end of row to act as stop, thus creating compacted bale row.
6. Lift first bale to height that will allow endcap to be placed over end of bale.
7. Place first bale onto bale deck.
8. Run first few bales through wrap chamber using manual wrap mode and with the rear cam axle raised. See [pg.6-2](#) and [Fig.2](#).
9. Adjust control screen settings according to bale size. Refer to **Setup Screen**, [pg.6-3](#).
10. Lower rear cam axle to ground using control screen before engaging auto wrap mode.



Fig.2

Auto Wrap Mode

1. Switch balewrapper control screen to auto wrap mode. Refer to [pg.6-1](#).
2. Use lifting machine to set bales on the bale deck. Bales must be placed on top of bale trigger to start the auto wrap cycle.
3. As bale ram returns to front of balewrapper continue placing bales onto bale deck until reaching the last bale of row.

Steering

The TL60ECV balewrapper is equipped with electric over hydraulic steering to keep the balewrapper headed in desired direction or to direct the wrapper around obstacles. For steering operation refer to **Control Panel Functions**, [pg.5-1](#).

CAUTION: Wrap on flat even surface to prevent balewrapper from drifting out of line.

NOTE: Prevent air pockets in bale row by avoiding sharp turns.

Steering can be done remotely with optional remote control. Refer to [pg.13-1](#).

Manual steering is not required with optional laser guidance system. Refer to [pg.20-1](#).

Stopping Cycle

If a problem occurs after the cycle has started in auto wrap mode, press Stop Cycle button on control screen. Refer to [pg.6-1](#).

Press control panel emergency stop to completely shut down balewrapper. Refer to [pg.5-1](#).

Optional Remote Start

Push the **STOP** button on the hand unit to stop the cycle. After the problem is rectified, finish the rest of the cycle in the manual wrap mode and then return to auto wrap mode. If you press start button on the hand unit it will also start the ram forward again but if the ram has passed the hoop start switch the hoop will not start with the ram. Refer to [pg.13-1](#).

Ending Bale Row



1. Switch balewrapper control screen to manual wrap mode. Refer to [pg.6-2](#).
2. Move bale ram return limit switch to end of slot.
3. Lift last bale to height necessary to place end cap on side facing front of bale wrapper.

NOTE: If placing last bale on wrapper with forked implement tape puncture holes to avoid bale spoil.

4. Place last bale on bale deck and manually push and wrap bale. See [Fig.1](#).
5. Stop the ram and wrap several more layers on the end of the bale.

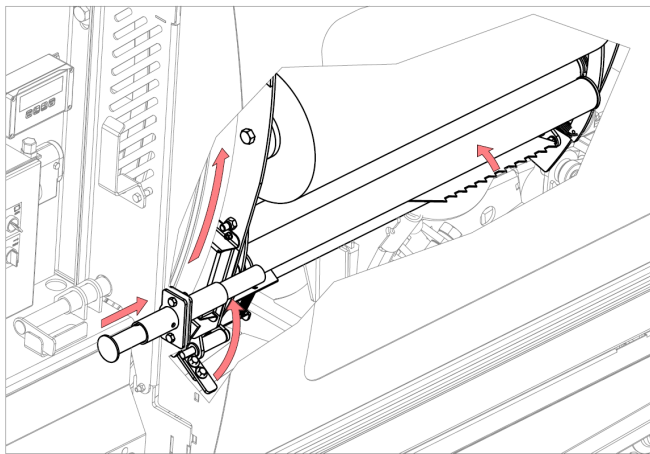

6. Cut plastic film by pressing and holding the film snap while rotating the hoop. See [Fig.2](#).
7. Push last bale to end of bale ram stroke.
8. Return bale ram to front home position.
9. Move linchpins from ram push plate hooks to storage position on ram. See [Fig.3](#).
10. Extend the final bale pushoff by pivoting the handle under the ram to the opposite side of the machine. See [Fig.4 & 5](#).

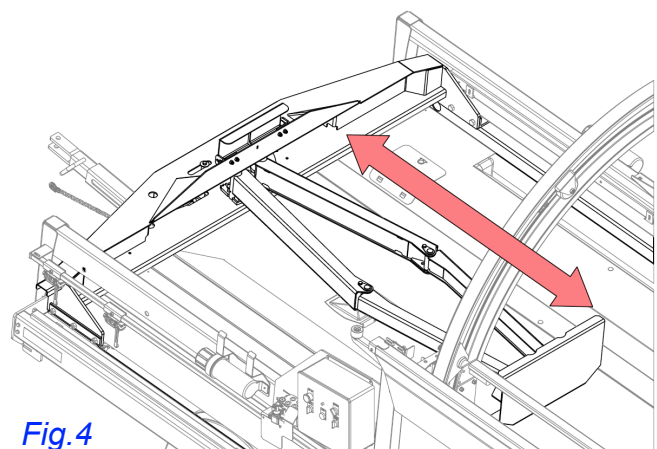
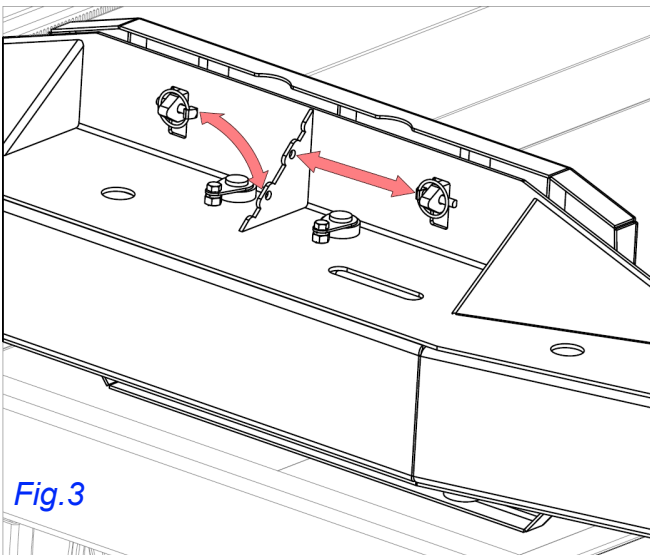

Fig.5

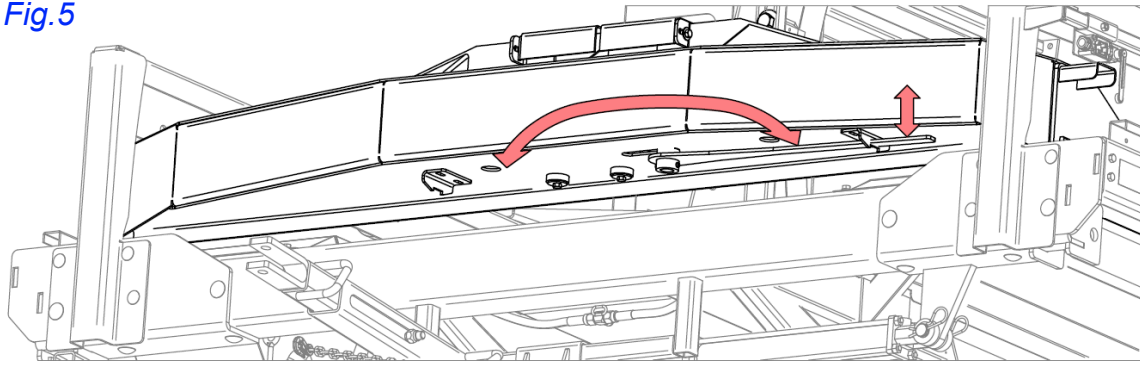
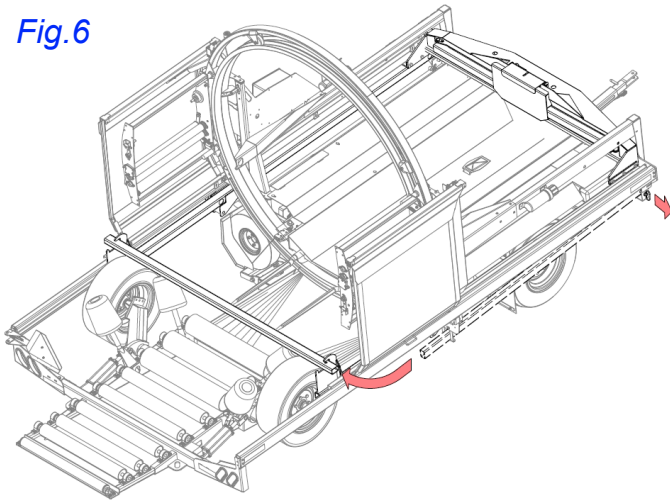

Fig.6



11. Move the bale row through the wrap chamber and onto the roller bed using the Ram REV control screen button. Refer to [pg.6-2](#).
12. Retract the bale ram to front home position by pressing the forward button on the control panel.
13. Return final bale pushoff to closed position using handle under ram.
14. Move linchpins from storage position on ram to lock ram push plate into its closed position.
15. Open the safety doors, remove 2 x 3 tube from its mounts on right side of the wrapper and lay it across the top of the pushoff hooks. See [Fig.6](#).

NOTE: Replace the pin in holder to avoid losing it.

16. Run the bale ram once more to completely push bales free of bale wrapper tail.

17. Open the safety doors, remove and store the 2 x 3 tube in storage brackets. Secure at front with lock pin.

NOTE: Bale wrappers equipped with optional dispatch arm do not require 2 x 3 tube. Refer to [Dispatch Arm Operation, pg.14-2](#).

After Wrapping

Inspect wrapped bale row for any holes on plastic film. Patch with tape if necessary. Label bale row with information such as wrap date, moisture percentage, foliage type, etc.

Section 8: Transporting Balewrapper

Transport Lock

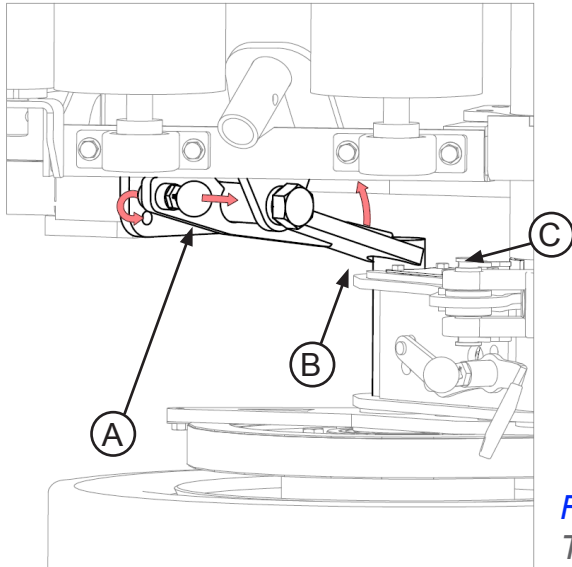

- Raise rear cam axle. Refer to **Control Screen Operation**, [pg.6-1](#).
- Engage transport lock by lifting spring pin (A) and swinging lock arm (B) over transport lock shaft (C). See [Fig.1](#).

[Fig.1](#)

Transport lock shown in locked position.

Disconnect Battery

Disconnect positive (+) red cable from battery located on right side of machine. Refer to [pg.3-2](#).

Fuel Shutoff - 13hp Engine Only

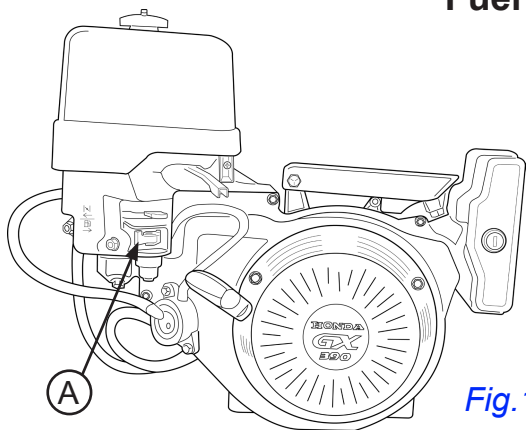

DANGER: Balewrappers equipped with 13hp Honda GX390 engine must have fuel valve (A) shutoff before transporting to avoid fuel spillage and engine damage. See [Fig.1](#).

[Fig.1](#)

Power Unit Hookup

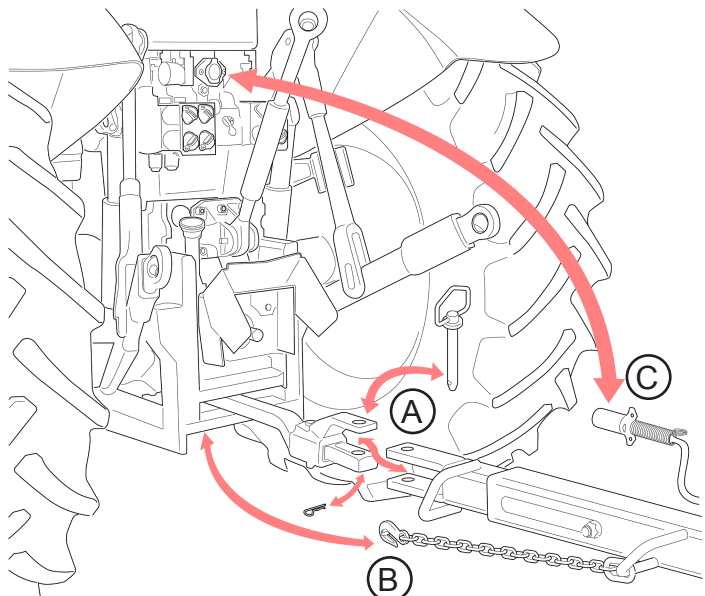

- Undo steering, unfold tongue and insert lock pin.
- Hitch tongue (A) to power unit drawbar with pin.
- Fasten safety chain (B) securely to power unit.
- Insert balewrapper's 7-pin connector (C) into power unit's matching receptacle. Refer to **Lighting & Marking**, [pg.2-2](#).
- Make sure parking brake is released before driving away.

[Fig.1](#)

Slow Moving Vehicle (SMV) Sign

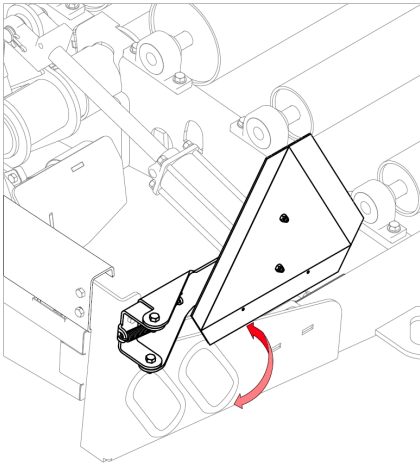

Swing SMV sign back into closed rear facing transport position if it has been flipped out during wrapping operation.

Observe Maximum Transport Speed

The maximum transport speed for this implement is 32 km/h (20 mph).

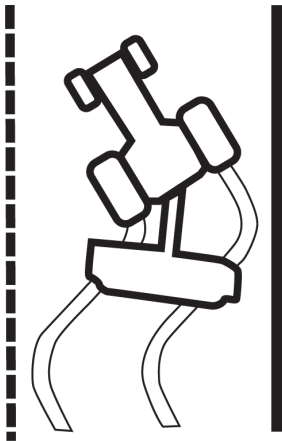

DANGER: Exceeding the implements maximum transport speed can result in:

- Loss of control of the tractor/implement combination.
- Reduced or no ability to stop during braking.
- Implement tire failure.
- Damage to the implement structure or its components

WARNING: Reduce speed when towing under adverse surface conditions, when turning, and when on inclines. Do not attempt transport if the fully loaded implement weighs more than 1.5 times the weight of the tractor.

DANGER: Do not allow riders on machine while transporting or operating.

DANGER: Do not climb on the bale deck or inside the wrap chamber while engine running.

Tire Pressure

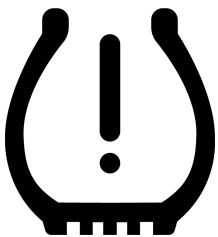

- Maintain proper tire pressure of 36 psi at all times.
- Do not over fill.
- Replace tires with same type if possible, or with same outside diameter.

Storage

- Extend the longevity of your machine store in sheltered area out of the elements and on a flat surface.
- Chock wheels after parking.
- Refer to [Maintenance Section](#) for recommended service and maintenance
- Cover balewrapper if necessary or preferred.

Section 9: Feeding

Feeding from Bale Row

Plastic film wrap will break away from bale row without cutting when removing bales. Remove any remaining plastic film from bale before placing into your feeder or feed area.

In general, exposed end bale will not spoil for 1-2 days in warmer weather and at least a week in colder weather. Remainder of wrapped bale row should not spoil with an exposed end.

Plastic Film Disposal

Follow these instructions for proper plastic film disposal:

- Collect and dispose all plastic film in an Environmentally Friendly manner.
- Use recycling services when available.
- Do not burn plastic film.
- Do not contaminate environment with loose plastic film.

Section 10: Maintenance

Grease Points

Grease decals on machine signify an area to occasionally grease. Use a high quality EP grease.

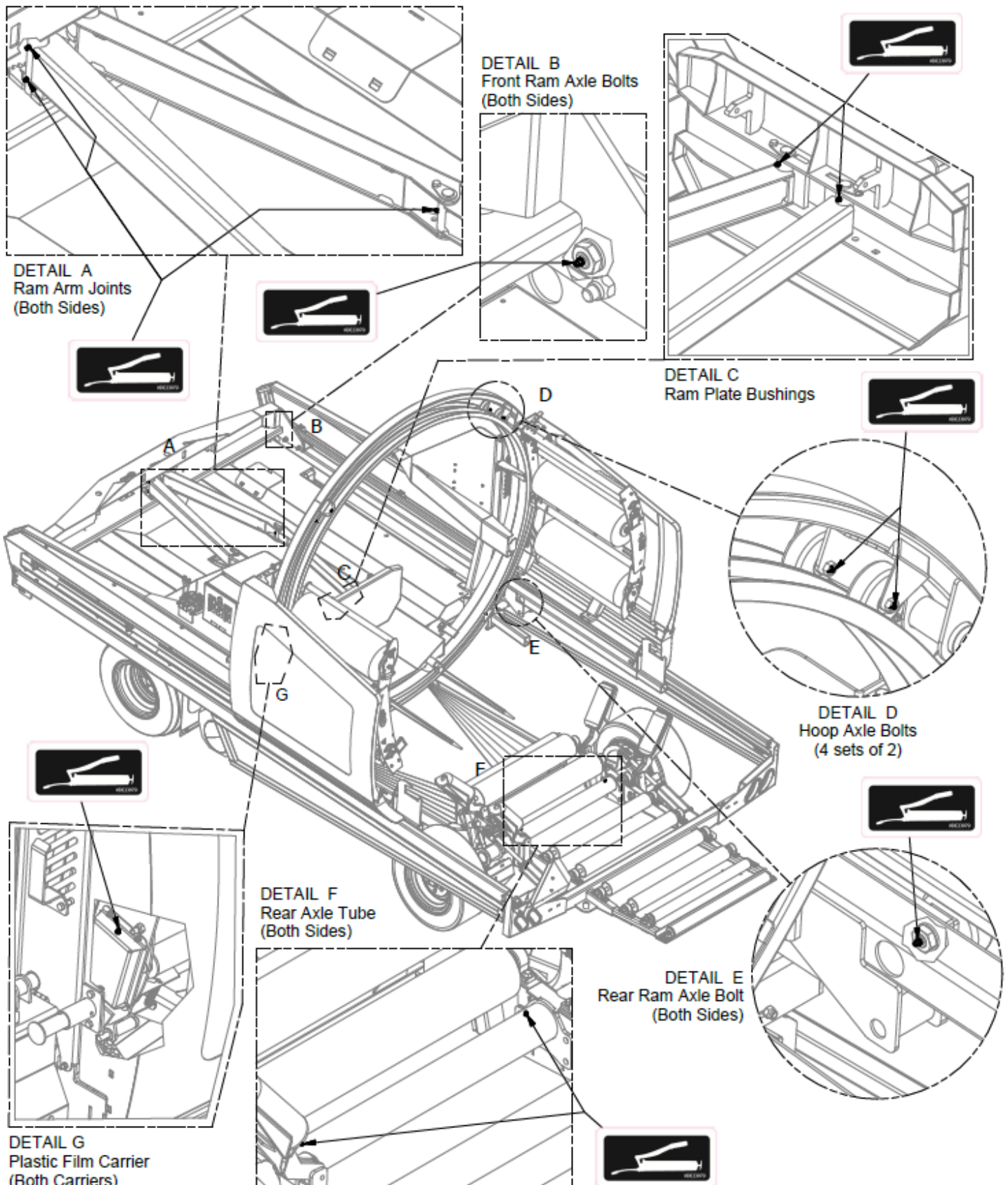

Grease Timeline

DETAIL	AREA	TIMELINE
A	Ram Arm Joints	Monthly
B	Front Ram Axle Bolts	Weekly
C	Ram Plate Bushings	Monthly
D	Hoop Axle Bolts	Twice Daily, 8 Bolts
E	Rear Ram Axle Bolts	Weekly
F	Rear Axle Tube	Monthly
G	Plastic Wrap Carriers / Gear Covers	Monthly

Hydraulic Oil

Use AW32 SAE10 hydraulic oil. Hydraulic oil tank is located in the middle of the balewrapper, under the bale deck. Check oil level gauge from right side of machine, see [Fig.1](#). Fill through cap mounted on rear of right fender, see [Fig.2](#). Leave about 1/4" from top of sight gauge to avoid overflow.

Follow recommended procedure in engine manual for proper engine maintenance and oil fill location.

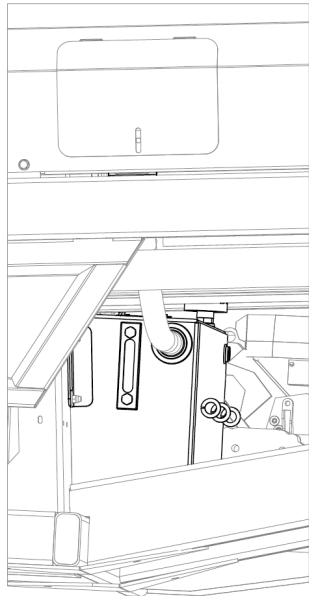

[Fig.1](#)

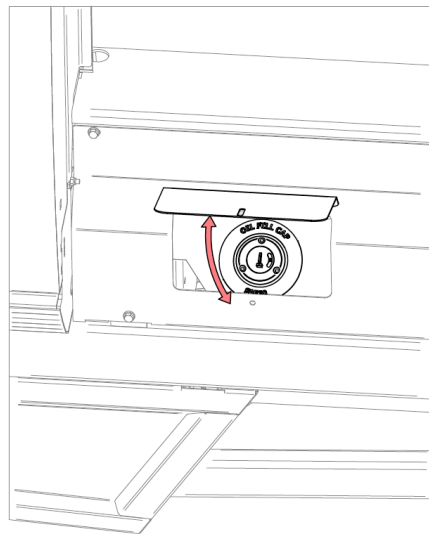

[Fig.2](#)

Hydraulic Oil Filter

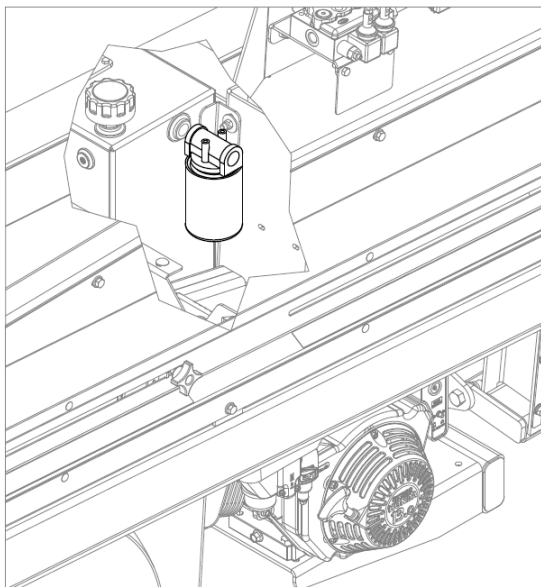

Oil filter is mounted on front side of oil tank. Replace oil filter after 60 hours of operation. See chart below for recommended oil filter replacement.

FILTER CROSS REFERENCE	
FILTER	REFERENCE
Stauf	SF6520
Gresen	F22001
Fram	P1653-A
Fleetguard	HF6510
Cross	1A9021

Troubleshoot Plastic Film and Carriers

1. Plastic film rips while wrapping:

- Hot weather causing adhesive tack buildup on rollers. Remove the adhesive with soap and water.
- Spray plastic wrap carrier rollers **(A)** with WD40.
- Store plastic rolls in a cool dry place before use.

OR

- Poor quality plastic, use a brand with good tear resistance.

2. Wrinkles in wrapped plastic with seams between layers visible:

- Check to determine if the plastic is properly routed through the carrier rollers. Install the plastic film rolls according to the Plastic Installation diagram, refer to [pg.4-1](#).

3. Plastic film carrier rollers not turning freely:

- Bearings have too much end pressure. Loosen the bolts holding the bearing.

OR

- Roller gears **(B)** meshed too tight. Slightly loosen one set of bearing bolts. Using a hammer and punch, lightly tap the bearing away from the other roller.



CAUTION: Do not use a hammer on the aluminum stretcher rolls.

4. Plastic film sticks to bale spears and tears the plastic inside the bale.

- Ensure bale sit firmly on the bale deck, bale spears should deflect the hay somewhat.

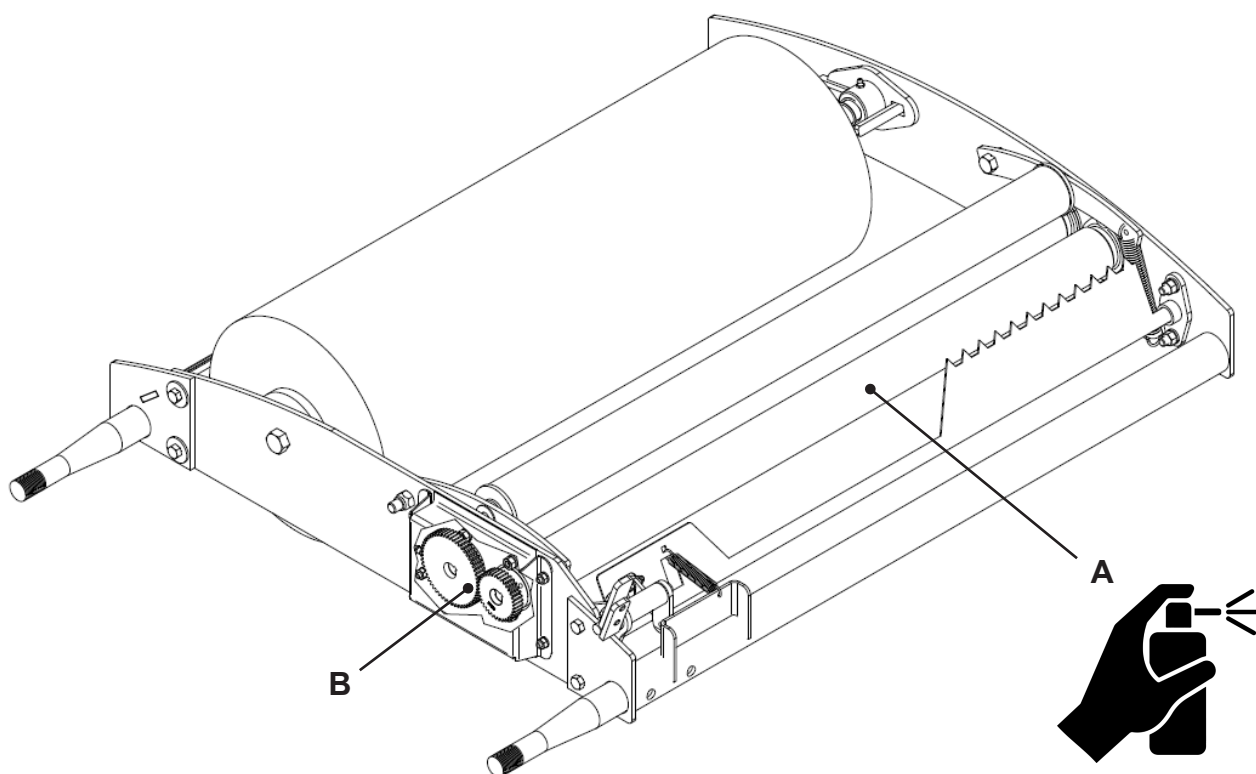

Section 12: Option - Power Drive

Refer to [Parts Manual](#) to confirm that you have all the parts necessary for this option.

Ensure bale wrapper is turned off and suitably parked before installing this option.

NOTE: Fully tighten all hose and hydraulic fittings after installation, before attempting to operate.

Power Drive Installation - Manifold

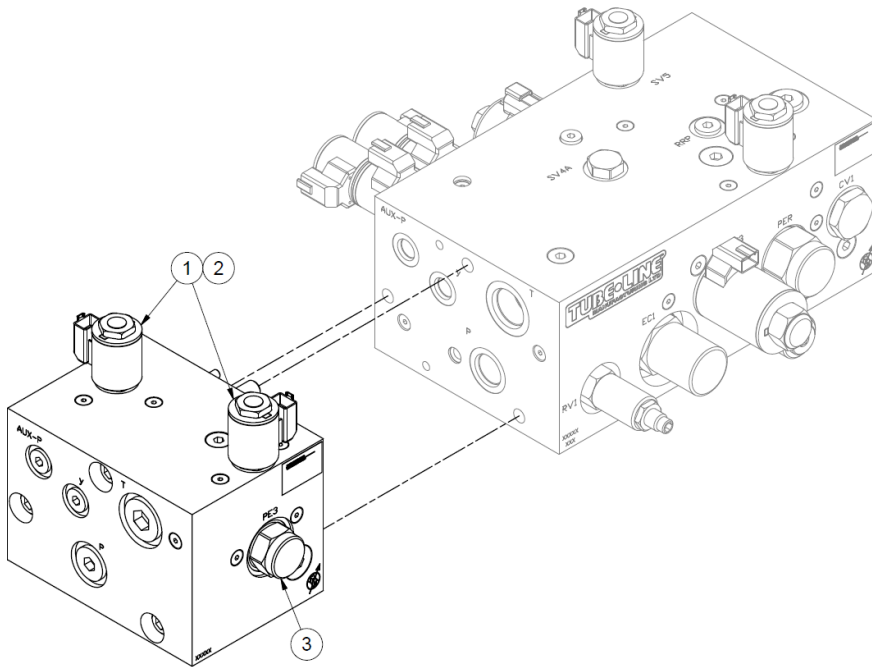

1. Unfasten the hose currently in the "P" port (located on the rear of the manifold valve).
2. Loosen and remove the 3 bolts from the same side as Step 1 (fig.1 on next page).
3. Bolt the new Power Drive Manifold (PDM) to rear of existing manifold, using 3 removed bolts.

Power Drive Installation - Wiring

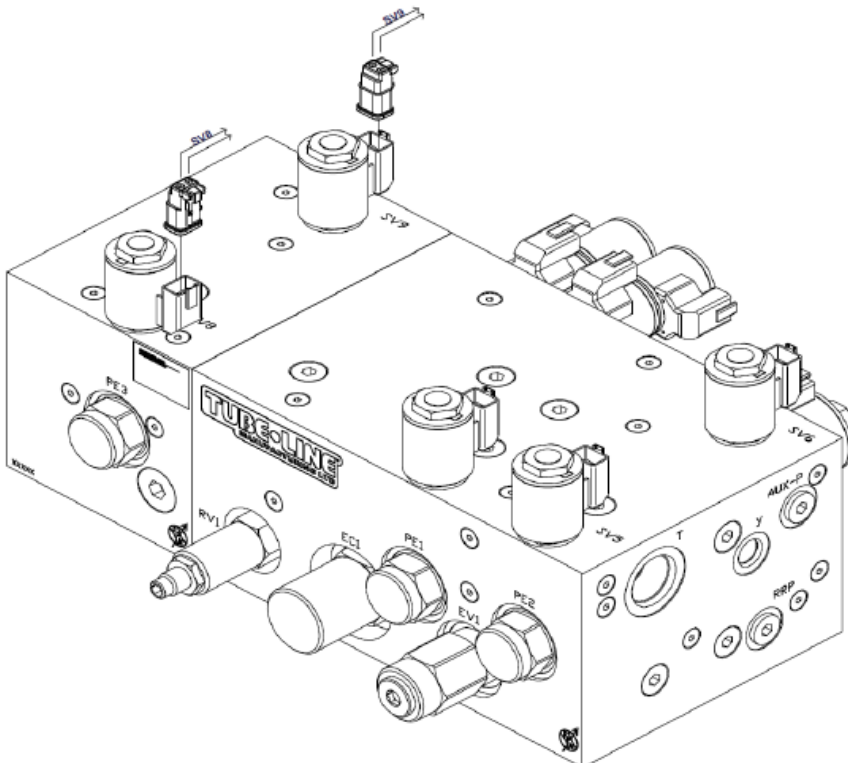

1. The wiring needed to run the electric valves on top of the power drive manifold built into the existing wiring harness.
2. Look behind the manifold you should see the wiring harness.
3. There will be two loose and capped wires that are labelled SV8 and SV9.
4. Remove the caps and insert them into the matching PDM solenoid sockets (SV8 & SV9) to complete power drive wiring circuit.

Power Drive Installation - Single

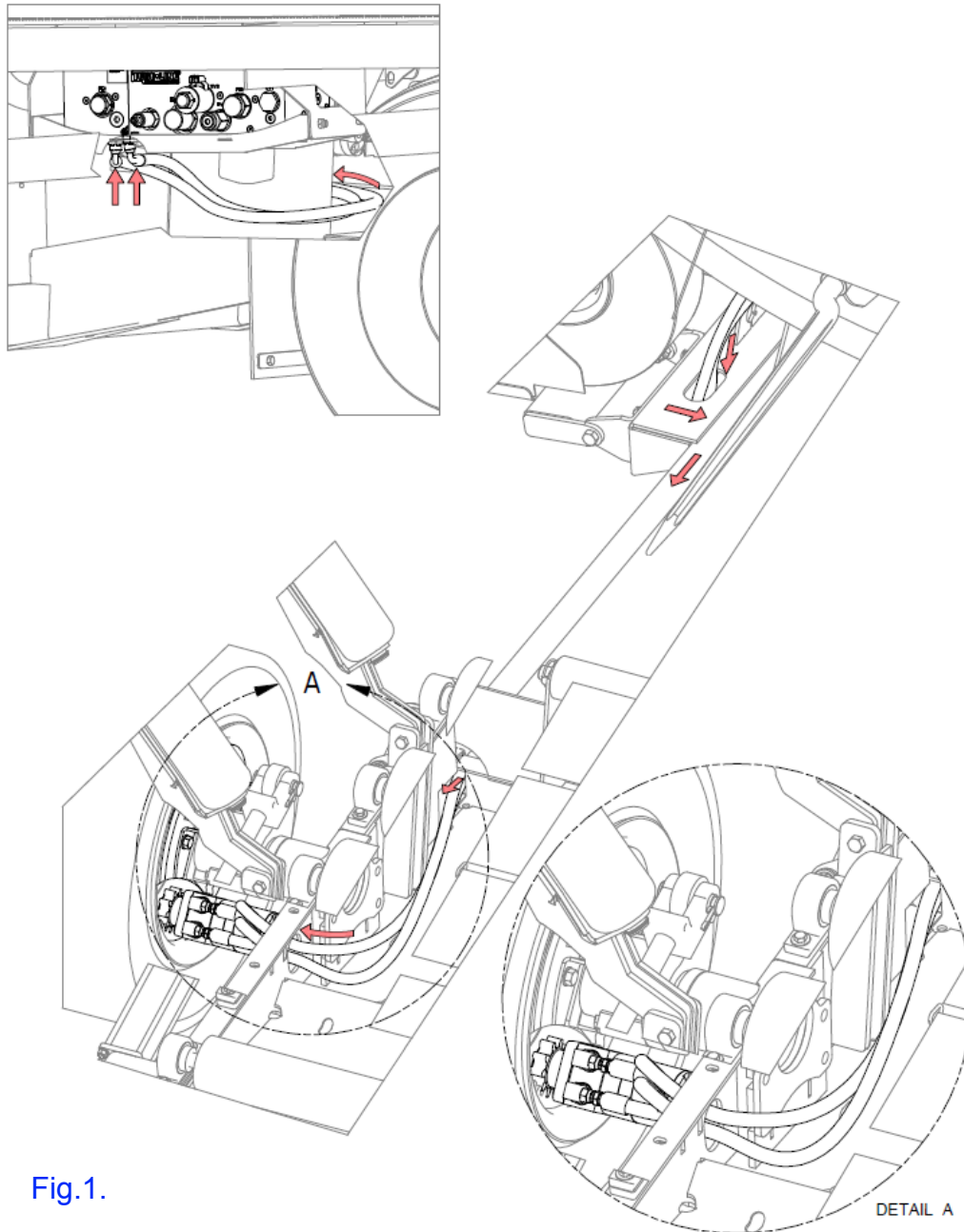

Fig.1.

1. Chock rear tires and disengage parking brake if it is set.
2. Remove existing brake pad from parking brake bracket. Reuse bolts to fasten supplied hydraulic motor as shown in Fig.1.
3. Ensure power drive gear sprocket meshes with the rim gear by engaging/ disengaging parking brake handle.
4. Route two supplied hoses from main manifold valve ports **DR** and **DF**, along front of oil tank, then through hoop wheel mount and side frame tube to middle of roller bed. Next pull the hoses through the left roller bed mount plate to the hydraulic motor. Make sure 90° hose ends are towards main manifold valve. See arrows in Fig.1.
5. Connect hoses as follows:
 - **DF** port to hydraulic motor fitting closest to wheel.
 - **DR** port to hydraulic motor fitting furthest from wheel.

Power Drive Installation - Dual

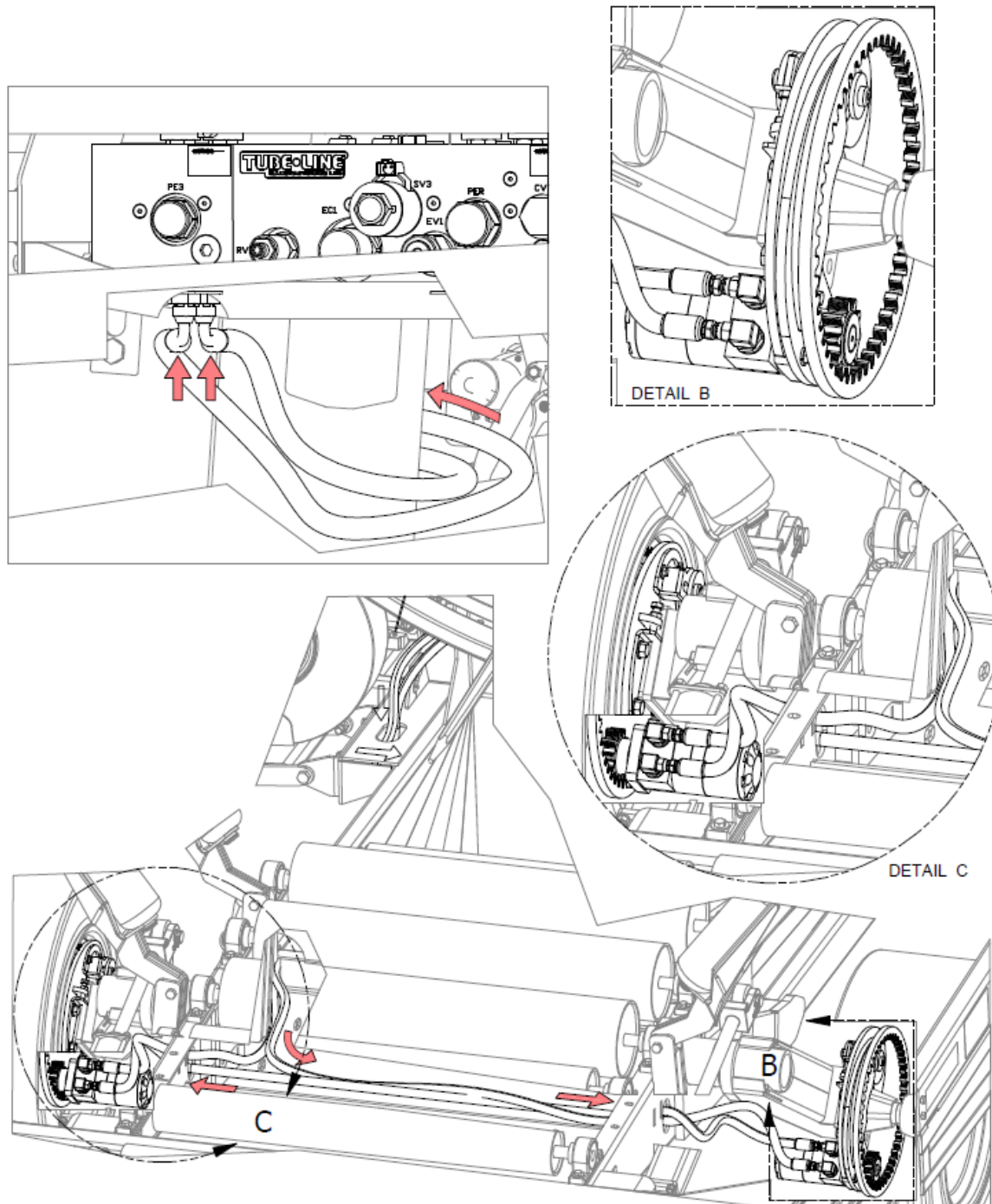

Fig.2.

1. Chock rear tires and disengage parking brake if it is set.
2. Remove existing brake pad from parking brake bracket. Reuse bolts to fasten supplied hydraulic motor as shown in Fig.2.
3. Bolt right side power drive bracket to right side of rear axle with supplied bolts and nuts. See [Parts Manual](#) for full assembly breakdown. **NOTE:** Right rear tire may need to be removed.
4. Ensure power drive gear sprockets mesh with rim gears by engaging/ disengaging handles.
5. Route hoses from main manifold valve ports **DR** and **DF** through hoop wheel mount and side frame tube to middle of roller bed, then through the left roller bed mount plate to the hydraulic motor. Make sure 90° hose ends are towards main manifold valve. See arrows in Fig.2.
6. Connect hoses as follows:

- **DF** port to left hydraulic motor fitting closest to wheel via shorter hose with 90° female JIC end.
- **DR** port to right hydraulic motor fitting closest to wheel via longer hose with 90° female JIC end.
- Connect left and right hydraulic motors using hose with straight JIC fitting ends.

Power Drive Operation

Enable powerdrive on control screen. Parameters page, as seen on [pg.6-4](#).

Powerdrive is only available when machine is in Auto Wrap Mode.

Press button on control screen to enable the Power Drive option, as shown below.

NOTE: This will deactivate after 30 seconds of inactivity.

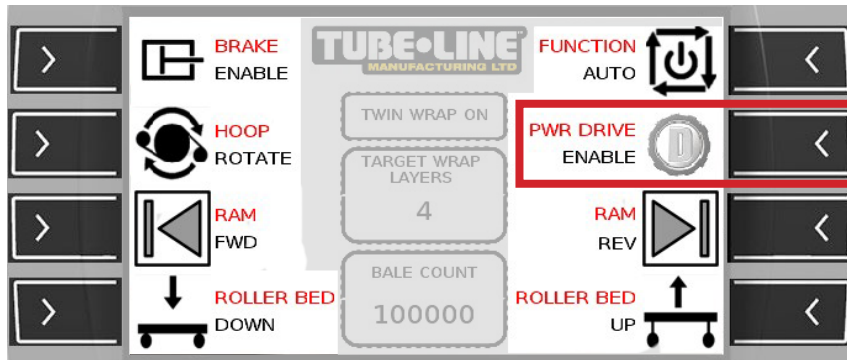
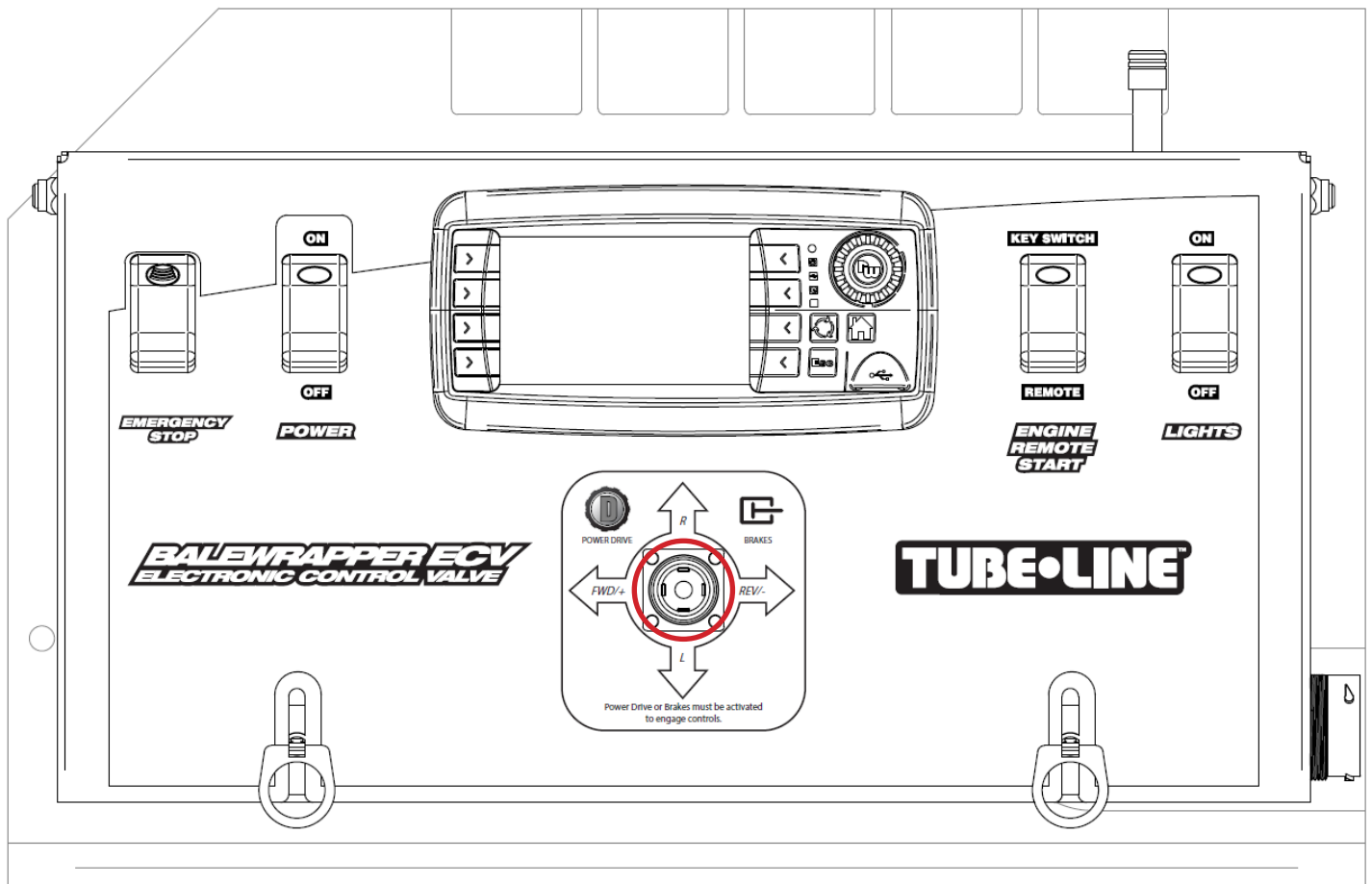

Fig.4.

Push toggle knob towards front of machine to drive the machine forward. Push the toggle knob towards the rear of machine to reverse the machine as desired.

Releasing knob will return it to neutral position and stop the bale wrapper from travelling further.



Section 13: Option - Remote Control

Remote Control Installation

- Bolt receiver circuit board assembly (A) inside control panel so antenna sticks through top of control panel.
- Connect remote antenna harness plug to matching control panel harness plug.

NOTE: All remote control units use the same frequency, no programming is required.

NOTE: Remote requires 2 AA batteries. Avoid rechargeable batteries, as the chemicals in these interfere with remote signals.

Remote Control Operation

Set control panel switch to “Remote Engine Start”

ON/OFF – Turns handheld unit on/off (detent has no function).

START – Starts the wrap cycle (unplug the table switch if you prefer to start each cycle with this button), this will not restart the hoop if cycle is broken after Hoop Start was triggered.

STOP – Stops the wrap cycle (if the table switch is not unplugged and it has a bale holding it down, it is necessary to hold stop until the circuit is broken by switching to manual mode at the control panel).

LEFT - Steers front tires left.

RIGHT - Steers front tires right.

Refer to Information page on display screen, [pg.6-4](#), to test remote connectivity.

NOTE: Store remote control inside tube marked “REMOTE ENCLOSED” on right side of machine when not in use.

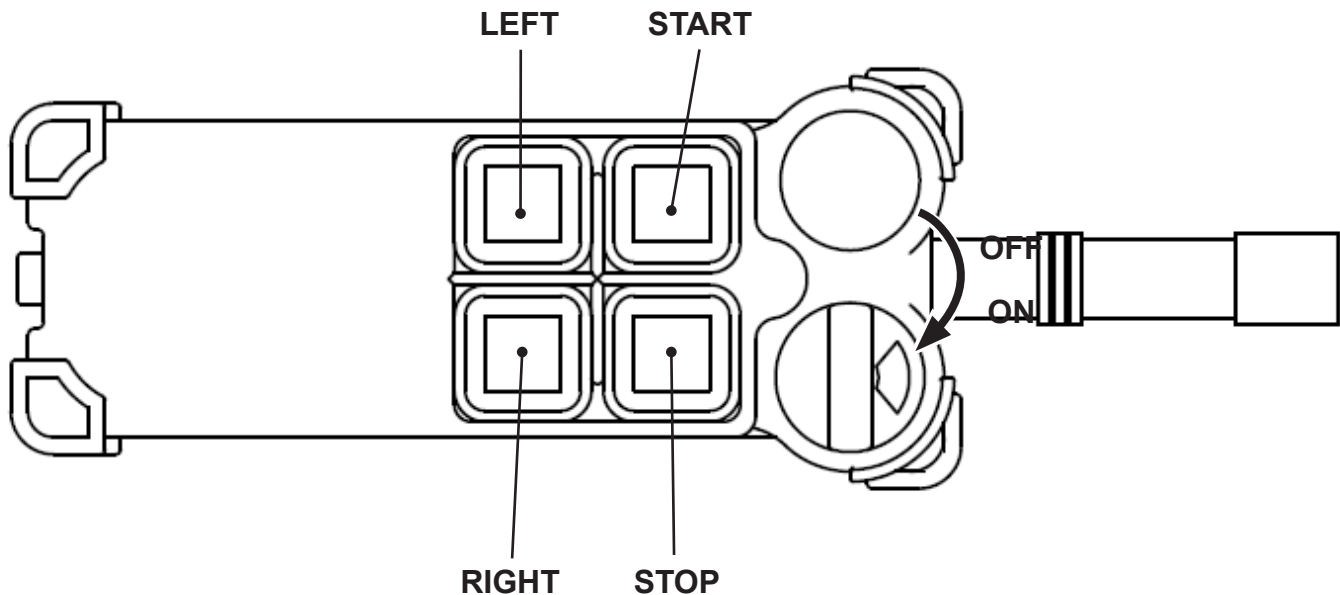

Section 14: Option - Plastic Film Sensor

Film Sensor Installation

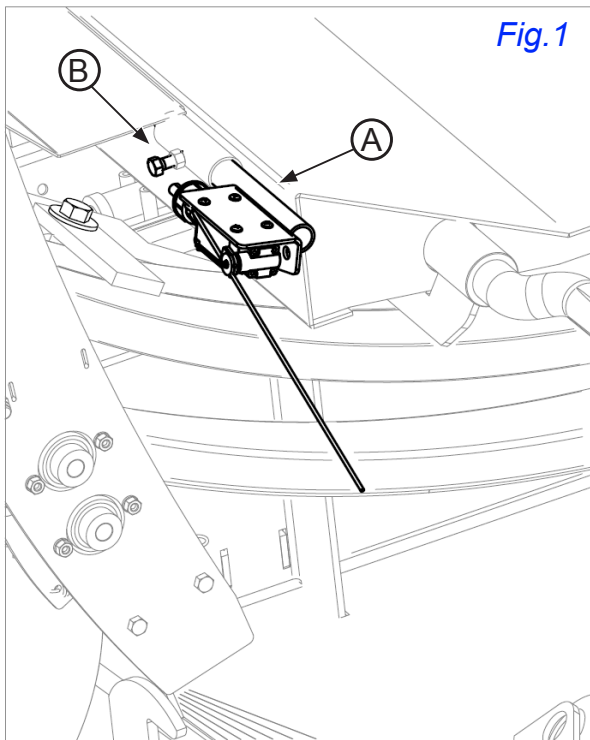

Ensure all parts have been received. Refer to [Parts Manual](#).

1. Install film sensor bracket (A) by sliding into frame tube and locking with provided bolt (B). See [Fig. 1](#).
2. Locate the "Film Sensor" wire attached to frame.
3. Remove plug from frame film sensor wire.
4. Connect frame film sensor wire plug and film sensor switch harness.

Plastic Film Sensor Adjustment

Sensor wire must be adjusted so that only one layer of plastic is covering the end of the wire while wrapping. Adjustment can be made on the bracket and on the sensor wire. The end of the sensor wire behind the switch can be bent to allow the wire in front of the switch to drop down far enough to trip the switch when no plastic is present.

NOTE: Use measurements as initial guide only.

- Measure length of wire from the hoop face (see previous page)
- 9.5" wire = approx. 3" between wraps = 8-9 layers per bale
- 9.5" wire should stop hoop rotation just after an empty tensioner passes the wire
- Lengthen wire 3" for 4 layers of wrap or 1.5" for 6 layers
- Shorten wire by 1.5" for 10 layers per bale

NOTE: As a guide, if the hoop stops before an empty plastic film carrier passes the film sensor wire, the wire is too short and if the hoop does not stop with one empty plastic film carrier the film sensor wire is too long.

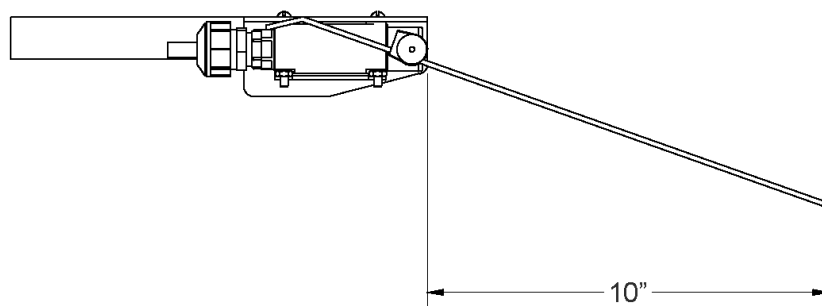

Plastic Film Sensor Operation

- Change Film Sensor field to “Enabled” on control panel screen. See [pg.6-3](#).
- Make sure plastic film sensor wire is on top of plastic film after installing new plastic rolls.
- Plastic film sensor wire drops when plastic film roll empties or breaks, causing wrap cycle to stop.

Section 15: Option - Wireless Plastic Film Sensor

Wireless Film Sensor Receiver Board Installation

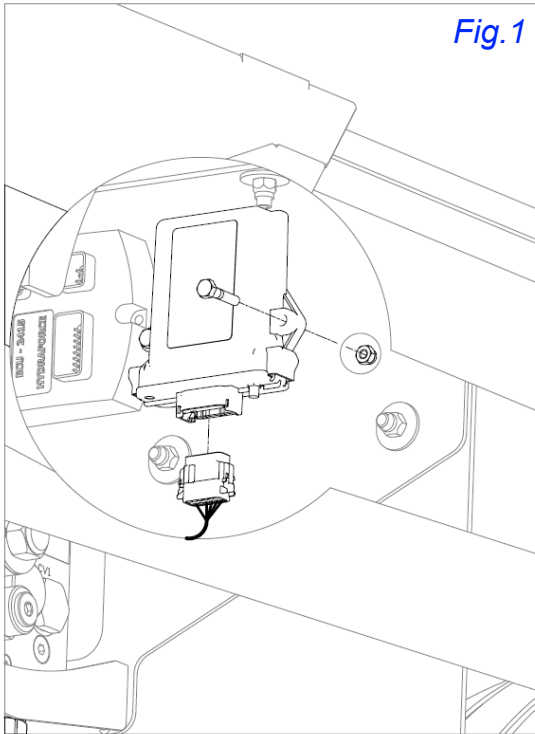

Fig. 1

Ensure all parts have been received. Refer to [Parts Manual](#).

1. Install film sensor receiver board casing to holes beside ECU under right side fender. See [Fig. 1](#).
2. Plug supplied harness into bottom of receiver board casing.
3. Follow the diagram in [Fig. 2](#) to wire the loose wire harness ends into bale wrapper's main wiring harness.
 - The cable wires marked ECU must be inserted into their matching main harness connectors. You will need to remove the backs of these connectors to insert the wireless film sensor harness pins.
 - Black and red power cables marked as "VEC" must run to the control panel. The control panel and fuse box will need to be opened.

Fig. 2

NOTE: All plugs shown from rear side.

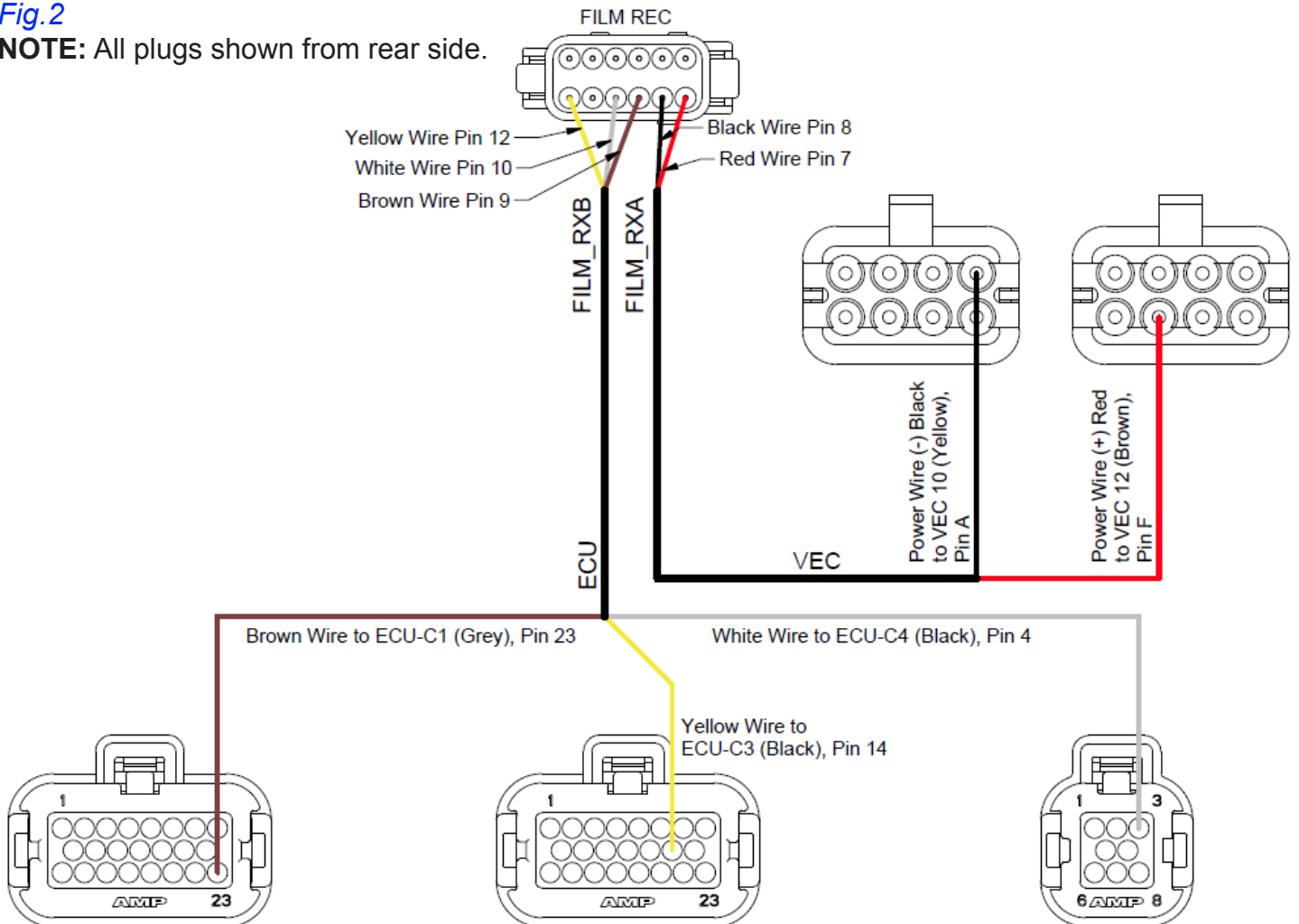

Wireless Film Sensor Transmitter Installation

Ensure all parts have been received. Refer to [Parts Manual](#).

1. Ensure two (2) 1.5V AAA alkaline batteries are inserted into each transmitter (A). See [Fig.1](#).

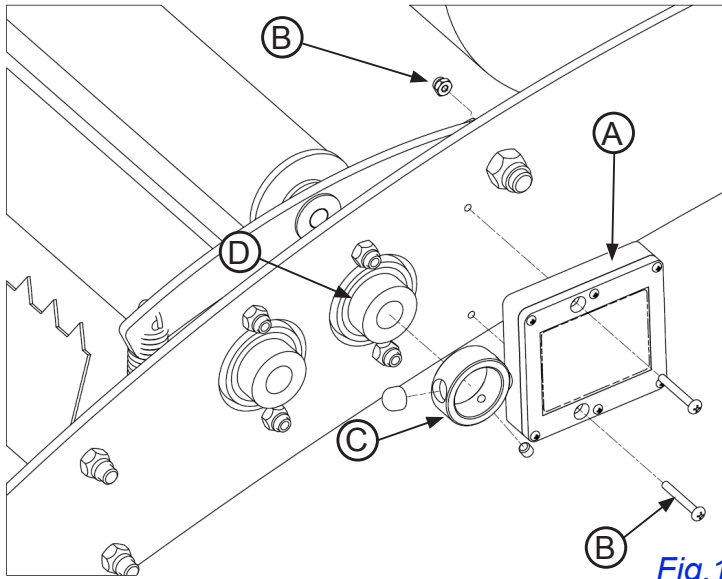

Fig.1

NOTE: When replacing batteries, **DO NOT** use rechargeable batteries. These can interfere with transmitter broadcasting.

2. Push magnet bushing (C) over closest roller bearing collar (D), backing off slightly to avoid wearing on wrap carrier. Ensure the magnet bushing is installed with set screws towards inside edge for full contact with roller bearing collar when tightened.
3. Drill holes through plastic wrap carrier frame so that when transmitter is mounted, it is 1/16" from tip of rare earth magnet. See [Fig.2](#).
4. Install transmitters on each plastic wrap carrier frame with provided machine screws and lock nuts (B). Transmitter end marked "MAGNET" positioned towards wrap carrier rollers. See decal image to left.

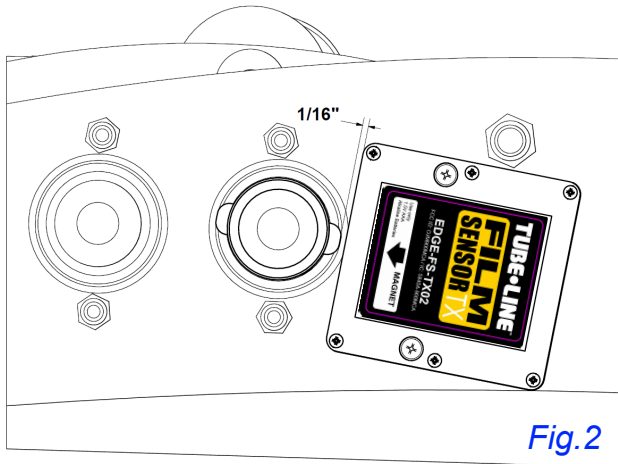

Fig.2

Wireless Film Sensor Operation

- Film sensor transmitter reads magnet bushing rotation as normal film dispensing.
- When a plastic roll empties or film breaks, magnet bushing stops rotating as no film is passing over its parent roller. The transmitter no longer senses magnet bushing rotation, signals the control panel receiver board which in turn signals the hoop controlling solenoid to cut off hydraulic flow to the hoop. This causes the wrap cycle to stop, ensuring no bales are pushed through the wrap chamber without plastic film coverage.

Section 16: Option - Dispatch Arm

Dispatch Arm Installation

Refer to [Parts Manual](#) to ensure all parts have been received.

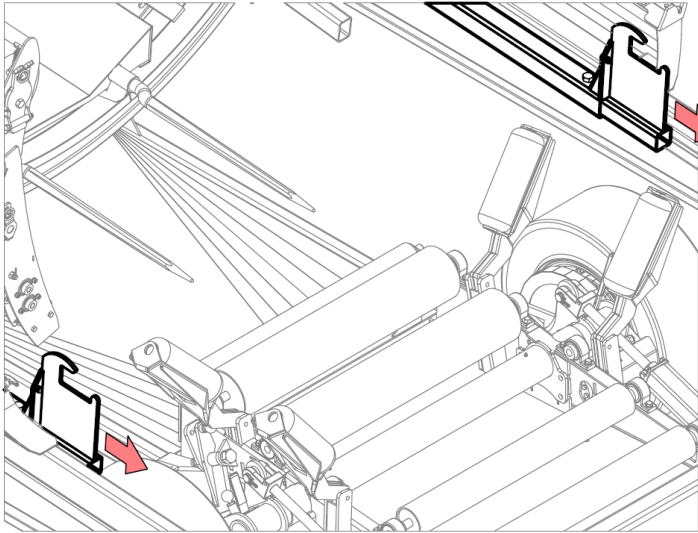

Fig.1

1. Remove standard last bale pushoff hooks from ram tubes. Keep unfastened hardware. See [Fig.1](#).
2. Insert right dispatch arm pocket into right ram tube. Lock with existing bolt and nut. See [Fig.2](#).
3. Use a lifting device to raise dispatch arm assembly.
4. Slide dispatch arm into left ram tube. Bolt with existing bolt and nut.
5. Lower dispatch arm to ensure it fits into right side pocket. See [Fig.3](#).

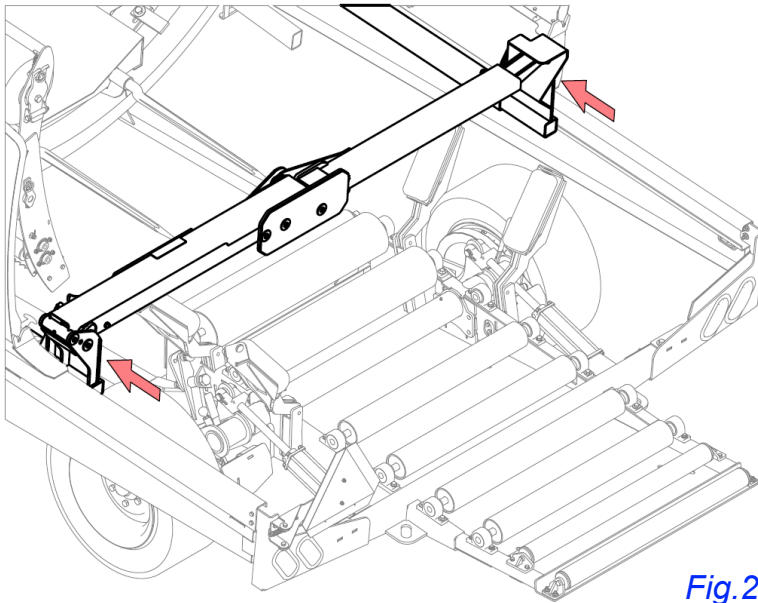

Fig.2

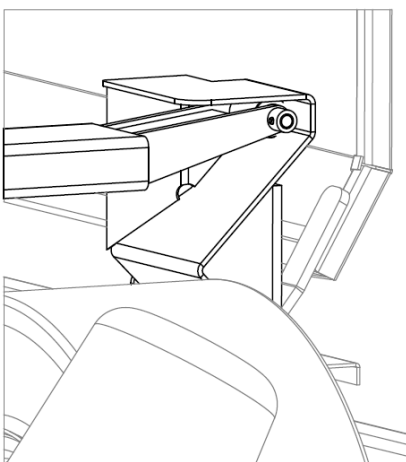
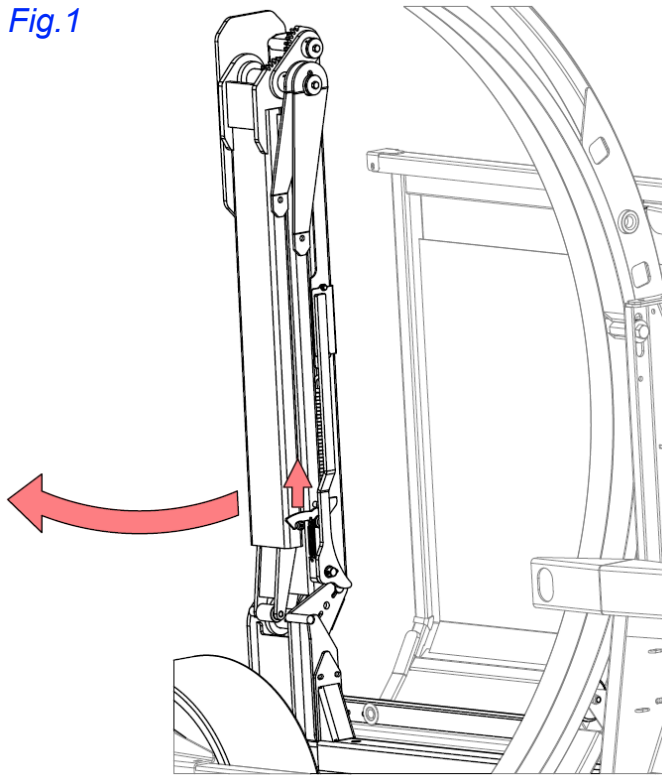

Fig.3

Dispatch Arm Operation

Fig.1



1. Unhook latch from lower inside edge of dispatch arm. See [Fig.1](#).
2. Use handle to unfold and lower the dispatch arm across the roller bed and into right side pocket.
3. Finish bale row as instructed in **Ending Bale Row**, [pg.7-3](#).
4. Raise dispatch arm to folded position with handle and lock latch if starting a new row. See [Fig.2](#).



WARNING: Keep dispatch arm in lowered position for highway transportation.

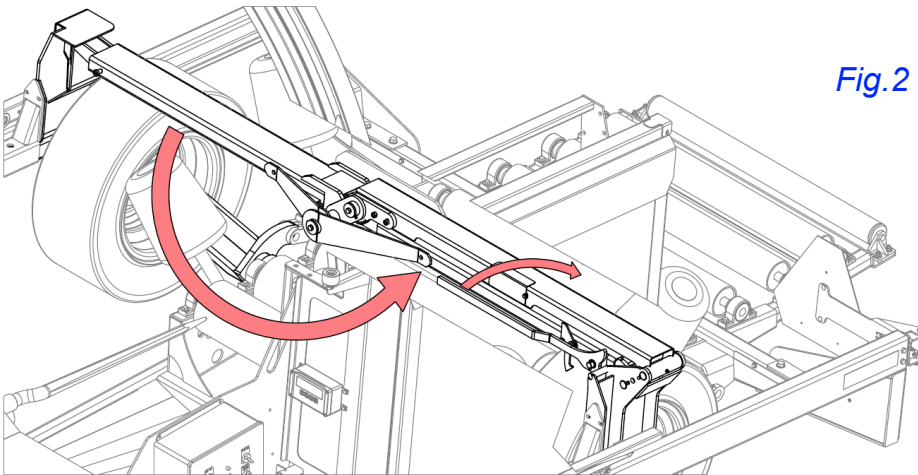

Fig.2

Section 17: Option - Guide Roller Kit

This option allows for better bale row alignment and may be necessary in uneven wrapping situations.

Guide Roller Kit Installation

Refer to [Parts Manual](#) to ensure all parts are included.

1. Slide left and right guide rollers into their respective holders.
2. Bolt in place with provided hardware.

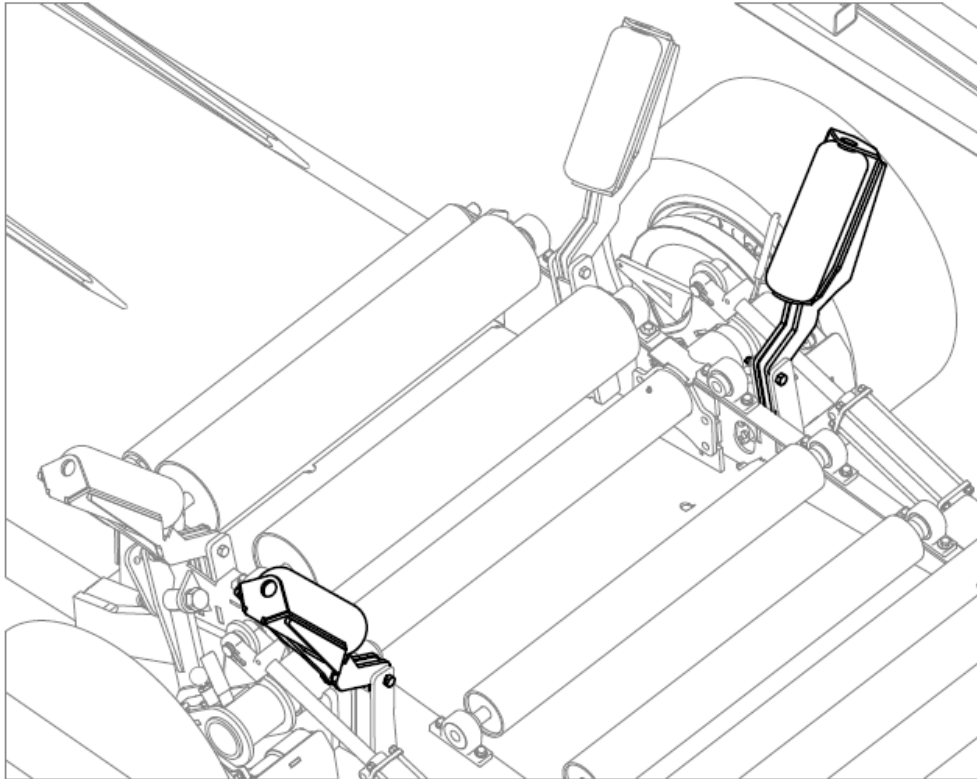

Section 18: Option - Night Light Kit

NOTE: Left and right light brackets are shipped pre-assembled. Both halogen and LED kits install the same way, only difference is the actual lights. Left side has three lights, right side has one.

Night Light Kit Installation

Refer to [Parts Manual](#) to ensure all parts are included.

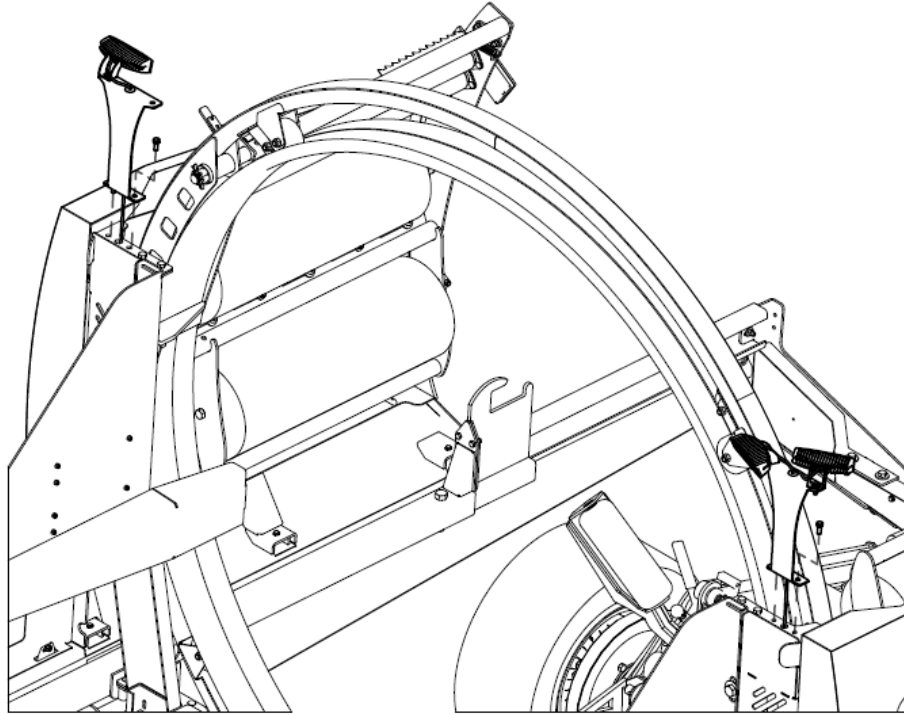

Fig.1

1. Install left side on top of left safety guard mount with provided hardware. See [Fig.1](#).
2. Install right on top of right safety guard mount with provided hardware.
3. Route night light kit wiring harness through large hole in top of safety guard mount.



WARNING: Ensure all machine power is switched off before installing electrical components.

4. Connect left and right night light wiring harness plugs to main frame harness plugs that are tied to safety guard mounts.

Night Light Kit Operation

1. Flip toggle switch on control panel to illuminate bale deck and wrap chamber. Refer to [pg.5-1](#).
2. Flip toggle switch again to turn off lights.

Section 19: Option - Twin Wrap Kit

Twin Wrap Kit Installation

Refer to [Parts Manual](#) to ensure all parts have been received.

1. Rotate hoop to a position where the twin wrap kit can be easily placed in position.



DANGER: Shutoff machine before installation.

2. Open left safety guard.
3. Place twin wrap kit on top of standard plastic film carrier.
4. Bolt in place with provided hardware. Handles must be placed through top side and fully tightened.
5. The 3 socket head bolts must be placed through bottom side. Do not fully tighten to allow tensioner to slide. See [Fig. 1](#).
6. Repeat steps 1-5 for other plastic wrap carrier.

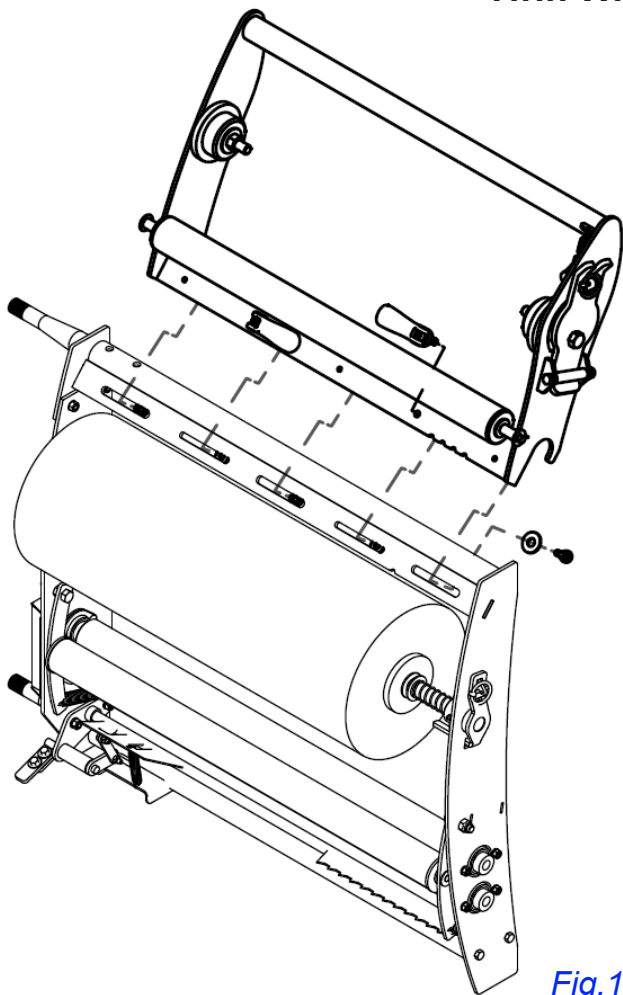

[Fig. 1](#)

Twin Wrap Kit Adjustments

1. Lift and turn handles to loosen twin wrap.
2. Slide twin wrap left or right to increase or decrease the plastic film layer overlap.
3. Turn handles to tighten twin wrap and push them down to lock in place.

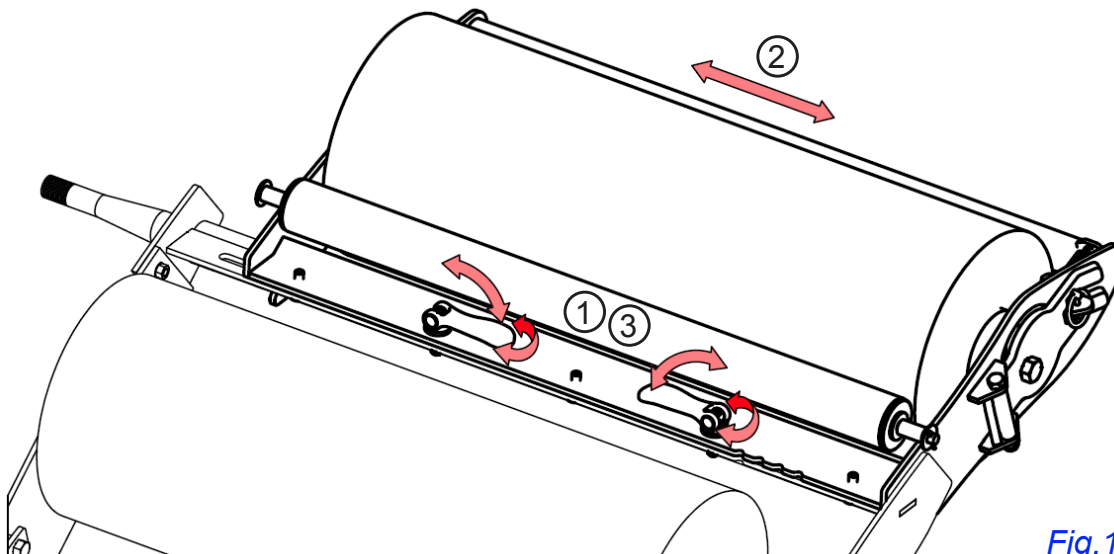

[Fig. 1](#)

Twin Wrap Plastic Film

See [Fig.1](#) to change twin wrap plastic rolls:

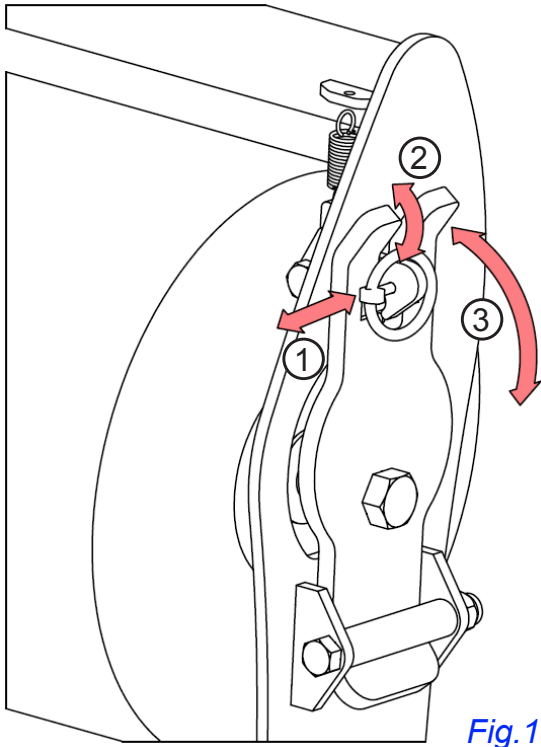

[Fig.1](#)

1. Remove linchpin.
2. Lift latch to unlock spool holder.
3. Pull spring spool holder out enough to remove the empty plastic roll from the spools.
4. Insert new plastic film roll into front spool holder.
5. Align other end of plastic film roll with spring spool holder.
6. Push spring spool holder into plastic film roll, ensure latch snaps into locked position.
7. Insert linchpin.
8. Route twin wrap plastic film over roller and under the existing standard plastic film roll. See [Fig.2](#).
9. Route both overlapping plastic film ends through standard film carrier rollers as specified on [pg.4-4](#).

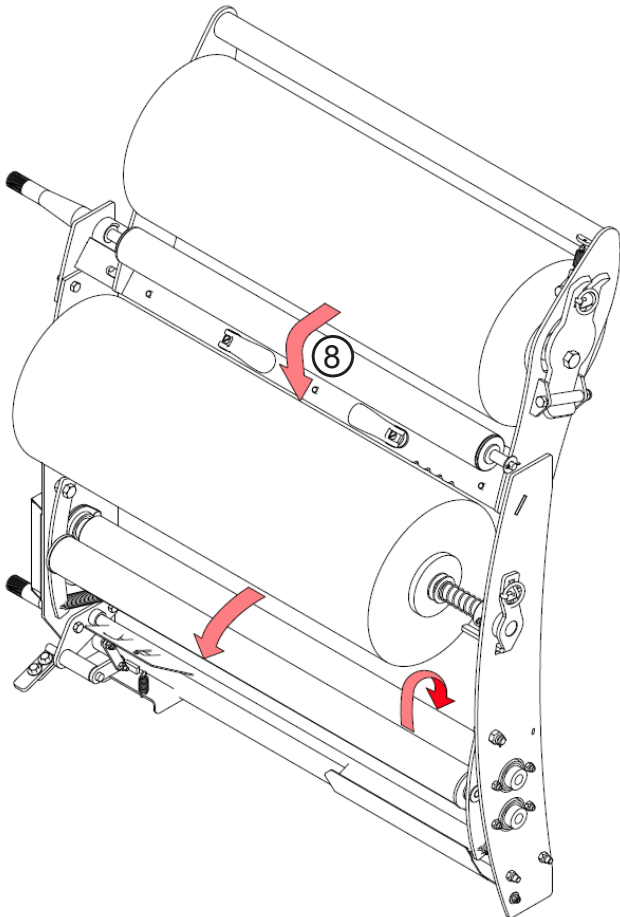

[Fig.2](#)

Section 20: Option - Laser Guidance System

Laser Guidance Installation

Refer to [Parts Manual](#) to ensure all parts are included.

To install your Laser Guidance System on a balewrapper follow these instructions:

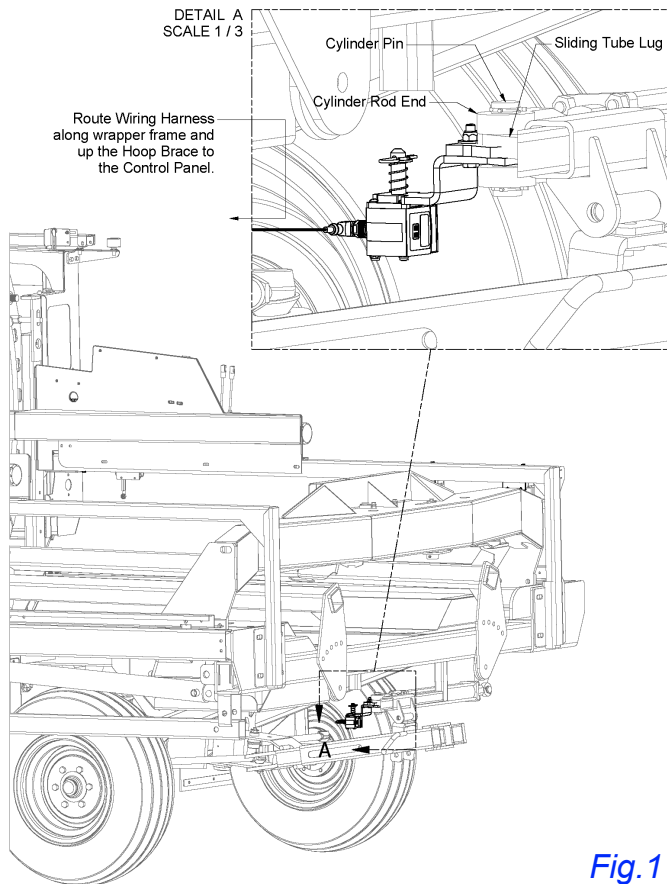

1. The laser sensor and mount assembly must be mounted to the rod side of the front steering cylinder. The pin holding the front steering cylinder rod end in place will need to be removed to allow the laser sensor mount bracket to slide between the cylinder rod end and the sliding tube lug.
2. Reinstall cylinder pin.
3. The communication cable must be routed down the door mount and hoop brace and along the balewrapper frame, up the door mount and hoop brace to the control panel. It must then be connected to the mounted laser sensor.

NOTE: It may be possible to route the communication cable along side existing wires.

4. Enable the laser guidance option using the control screen Parameters page, see [pg.6-4](#).

Fig.1

Laser Guidance Adjustment

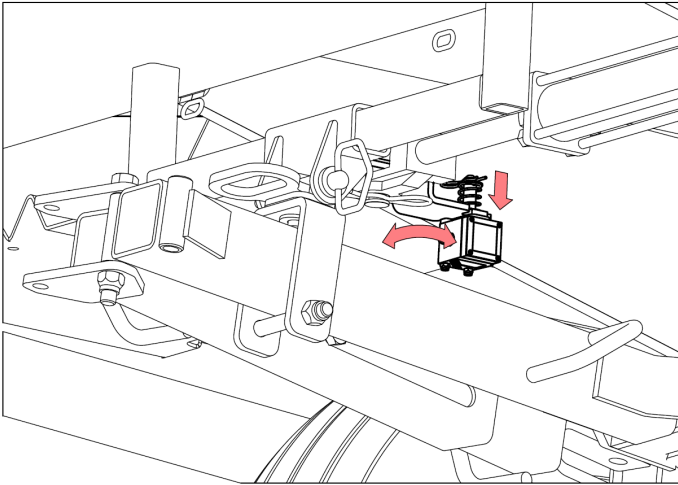

Fig.1

1. The mirrored face of the sensor must be pointing towards the row you want the wrapper to follow. The sensor can be repositioned as needed by pulling down on the sensor, then pivoting it in the correct position. See Fig.1.
2. Release the sensor. The machine screw heads holding the sensor to its mounting plate should fit neatly into the pivot plate to lock the necessary position in place.
3. After setting the laser eye to the desired direction go to the control panel screen Setup page, Fig.2, and set “Laser Steering” text box to match direction of laser eye.
4. Change value of Setup screen “Target Laser Distance [in]” text box to desired distance to guiding bale row. These can be set in increments of 4”, starting at 38”.

NOTE: The home screen sections, shown in Fig.3, “Laser Steering” and “Actual Distance” are informative only.

SETUP			
TWIN WRAP	NO	60	AUTO WRAP BALE WIDTH [IN]
TARGET WRAP LAYERS	10	42	AUTO WRAP BALE OPENING [IN]
FILM SENSOR	ENABLED	6	AUTO HOOP START DELAY [IN]
ENABLE TIMER [s]	10	0	BALE COUNT ADJUST
LASER STEERING	LEFT	42 (40 in ACTUAL)	TARGET LASER DISTANCE [IN]

Fig.2

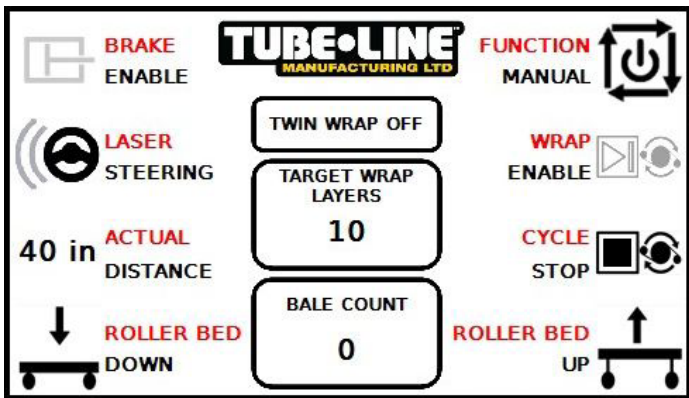

Fig.3

Section 21: Option - Roadflex Suspension Axle

NOTE: Only available for front axle. Decreases stress to machine frame and bale deck while placing bales.

Suspension Axle Installation













WARNING: Do not attempt this installation without properly bracing the machine and blocking wheels to prevent rolling. Install while machine on flat surface.

- Unbolt and remove existing front axle.
- Use hoist and a helper to lift the new axle into position.
- Use hardware from standard front axle to bolt suspension axle in place.

Imperial Torque Value Chart

UNIFIED INCH BOLT AND CAP SCREW TORQUE VALUES

SAE Grade and Head Markings	1 or 2 ^b	5	5.1	5.2	8	8.2
	NO MARK 					
SAE Grade and Nut Markings	2	5		8		
	NO MARK 					

T81162 -19-03M4109

Size	Grade 1				Grade 2 ^b				Grade 5, 5.1, or 5.2				Grade 8 or 8.2			
	Lubricated ^a		Dry ^a		Lubricated ^a		Dry ^a		Lubricated ^a		Dry ^a		Lubricated ^a		Dry ^a	
	N-m	lb-ft	N-m	lb-ft	N-m	lb-ft	N-m	lb-ft	N-m	lb-ft	N-m	lb-ft	N-m	lb-ft	N-m	lb-ft
1/4	3.7	2.8	4.7	3.5	6	4.5	7.5	5.5	9.5	7	12	9	13.5	10	17	12.5
5/16	7.7	5.5	10	7	12	9	15	11	20	15	25	18	28	21	35	26
3/8	14	10	17	13	22	16	27	20	35	26	44	33	50	36	63	46
7/16	22	16	28	20	35	26	44	32	55	41	70	52	80	58	100	75
1/2	33	25	42	31	53	39	67	50	85	63	110	80	120	90	150	115
9/16	48	36	60	45	75	56	95	70	125	90	155	115	175	130	225	160
5/8	67	50	85	62	105	78	135	100	170	125	215	160	240	175	300	225
3/4	120	87	150	110	190	140	240	175	300	225	375	280	425	310	550	400
7/8	190	140	240	175	190	140	240	175	490	360	625	450	700	500	875	650
1	290	210	360	270	290	210	360	270	725	540	925	675	1050	750	1300	975
1-1/8	400	300	510	375	400	300	510	375	900	675	1150	850	1450	1075	1850	1350
1-1/4	570	425	725	530	570	425	725	530	1300	950	1650	1200	2050	1500	2600	1950
1-3/8	750	550	950	700	750	550	950	700	1700	1250	2150	1550	2700	2000	3400	2550
1-1/2	1000	725	1250	925	990	725	1250	930	2250	1650	2850	2100	3600	2650	4550	3350

DO NOT use these values if a different torque value or tightening procedure is given for a specific application. Torque values listed are for general use only. Check tightness of fasteners periodically.

Shear bolts are designed to fail under predetermined loads. Always replace shear bolts with identical grade.

^a "Lubricated" means coated with a lubricant such as engine oil, or fasteners with phosphate and oil coatings. "Dry" means plain or zinc plated without any lubrication.

^b Grade 2 applies for hex cap screws (not hex bolts) up to 152 mm (6-in.) long. Grade 1 applies for hex cap screws over 152 mm (6-in.) long, and for all other types of bolts and screws of any length.





















Fasteners should be replaced with the same or higher grade. If higher grade fasteners are used, these should only be tightened to the strength of the original.

Make sure fasteners threads are clean and that you properly start thread engagement. This will prevent them from failing when tightening.

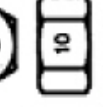
Tighten plastic insert or crimped steel-type lock nuts to approximately 50 percent of the dry torque shown in the chart, applied to the nut, not to the bolt head. Tighten toothed or serrated-type lock nuts to the full torque value.

Metric Torque Value Chart

METRIC BOLT AND CAP SCREW TORQUE VALUES

Property Class and Head Markings	4.8		8.8		9.8		10.9		12.9	
										
Property Class and Nut Markings	5		10		10		10		12	
										

Size	Class 4.8				Class 8.8 or 9.8				Class 10.9				Class 12.9			
	Lubricated ^a		Dry ^a		Lubricated ^a		Dry ^a		Lubricated ^a		Dry ^a		Lubricated ^a		Dry ^a	
	N-m	lb-ft	N-m	lb-ft	N-m	lb-ft	N-m	lb-ft	N-m	lb-ft	N-m	lb-ft	N-m	lb-ft	N-m	lb-ft
M6	4.8	3.5	6	4.5	9	6.5	11	8.5	13	9.5	17	12	15	11.5	19	14.5
M8	12	8.5	15	11	22	16	28	20	32	24	40	30	37	28	47	35
M10	23	17	29	21	43	32	55	40	63	47	80	60	75	55	95	70
M12	40	29	50	37	75	55	95	70	110	80	140	105	130	95	165	120
M14	63	47	80	60	120	88	150	110	175	130	225	165	205	150	260	190
M16	100	73	125	92	190	140	240	175	275	200	350	255	320	240	400	300
M18	135	100	175	125	260	195	330	250	375	275	475	350	440	325	560	410
M20	190	140	240	180	375	275	475	350	530	400	675	500	625	460	800	580
M22	260	190	330	250	510	375	650	475	725	540	925	675	850	625	1075	800
M24	330	250	425	310	650	475	825	600	925	675	1150	850	1075	800	1350	1000
M27	490	360	625	450	950	700	1200	875	1350	1000	1700	1250	1600	1150	2000	1500
M30	675	490	850	625	1300	950	1650	1200	1850	1350	2300	1700	2150	1600	2700	2000
M33	900	675	1150	850	1750	1300	2200	1650	2500	1850	3150	2350	2900	2150	3700	2750
M36	1150	850	1450	1075	2250	1650	2850	2100	3200	2350	4050	3000	3750	2750	4750	3500

DO NOT use these values if a different torque value or tightening procedure is given for a specific application. Torque values listed are for general use only. Check tightness of fasteners periodically.

Shear bolts are designed to fail under predetermined loads. Always replace shear bolts with identical property class.

Fasteners should be replaced with the same or higher property class. If higher property class fasteners are used, these should only be tightened to the strength of the original.

^a "Lubricated" means coated with a lubricant such as engine oil, or fasteners with phosphate and oil coatings. "Dry" means plain or zinc plated without any lubrication.

Make sure fasteners threads are clean and that you properly start thread engagement. This will prevent them from failing when tightening.

Tighten plastic insert or crimped steel-type lock nuts to approximately 50 percent of the dry torque shown in the chart, applied to the nut, not to the bolt head. Tighten toothed or serrated-type lock nuts to the full torque value.

Index

Advantages to High Moisture Hay	I
Advantages to Wrapping Bales	I
After Wrapping7-4
Auto Mode Test Run3-3
Auto Wrap Mode7-2
Auto Wrap Mode Screen Functions6-1
Bales1-1
Bale Saddle Adjustment.4-4
Balewrapper Starting7-1
Battery Hookup3-2
Control Screen Error Messages6-2
Dealer Installation3-1
Dimensions1-1
Disconnect Battery8-1
Dispatch Arm Installation	16-1
Dispatch Arm Operation.	16-2
Door Switch Adjustment.4-1
Ending Bale Row7-3
Feeding from Bale Row9-1
Film Sensor Installation	14-1
Fuel Shutoff - 13hp Engine Only8-1
General Button Functions6-1
Grease Points	10-1
Grease Timeline	10-2
Guide Roller Kit Installation.	17-1
Hydraulic Oil	10-2
Hydraulic Oil Filter	10-2
Imperial Torque Value ChartVII
Information Screen6-4
In-line Wrapper 3 Year Limited Warranty Statement (<i>Excludes Individual Wrapper</i>).	II
Laser Guidance Adjustment	20-2
Laser Guidance Installation	20-1
Lighting2-2
Manifold Solenoid Functions	11-1
Manual Mode Test Run3-3
Manual Wrap Mode Screen Functions6-2
Metric Torque Value ChartVIII
Night Light Kit Installation	18-1
Night Light Kit Operation	18-1
Observe Maximum Transport Speed.8-2
Operator's Manual	I
Optional Remote Start7-2
Orientation1-2
Parameters Screen6-4

Personal Protective Equipment2-2
Plastic Film Disposal.9-1
Plastic Film Installation4-1
Plastic Film Sensor Adjustment	14-1
Plastic Film Sensor Operation	14-2
Power Drive Installation - Dual.	12-3
Power Drive Installation - Manifold	12-1
Power Drive Installation - Single	12-2
Power Drive Installation - Wiring	12-1
Power Drive Operation	12-4
Power Unit Hookup8-1
Pre-Operating Inspection3-3
Remote Control Installation.	13-1
Remote Control Operation	13-1
Safety Decal Illustrations2-5
Safety Decal Locations2-4
Safety Guidelines.2-1
Safety Signal Words / Safety Messages.2-1
Section 1: General Information1-1
Section 2: Safety2-1
Section 3: Setup3-1
Section 4: Adjustments4-1
Section 5: Control Panel Operation5-1
Section 6: Control Screen Operation.6-1
Section 7: Operation.7-1
Section 8: Transporting Balewrapper.8-1
Section 9: Feeding9-1
Section 10: Maintenance	10-1
Section 11: Diagnostics	11-1
Section 12: Option - Power Drive	12-1
Section 13: Option - Remote Control.	13-1
Section 14: Option - Plastic Film Sensor	14-1
Section 15: Option - Wireless Plastic Film Sensor.	15-1
Section 16: Option - Dispatch Arm	16-1
Section 17: Option - Guide Roller Kit.	17-1
Section 18: Option - Night Light Kit	18-1
Section 19: Option - Twin Wrap Kit	19-1
Section 20: Option - Laser Guidance System	20-1
Section 21: Option - Roadflex Suspension Axle	21-1
Serial Number.1
Setup Screen6-3
Slow Moving Vehicle (SMV) Sign8-2
Starting a Bale Row7-1
Steering.7-2
Stopping Cycle7-2
Storage8-2

Suitable Wrapping Timeframe1-1
Suspension Axle Installation	21-1
Terminology1-2
Tire Pressure8-2
Transport Lock8-1
Troubleshoot Plastic Film and Carriers	11-2
Twin Wrap Kit Adjustments	19-1
Twin Wrap Kit Installation	19-1
Twin Wrap Plastic Film	19-2
Usage1-1
Wireless Film Sensor Operation	15-2
Wireless Film Sensor Reciever Board Installation	15-1
Wireless Film Sensor Transmitter Installation	15-2
Wrapping Site3-3
Wrapping Straw1-1



WARNING

The engine exhaust from this product contains chemicals known in the state of California to cause cancer, birth defects, or other reproductive harm.

TUBE•LINE™