

TUBE•LINE™

Tubeline Manufacturing Limited
6455 Reid Woods Drive RR #4
Elmira, Ontario, Canada N3B 2Z3

Email: sales@tubeline.ca

Fax: 519.669.5808

Tel: 519.669.9488

Toll-free (North America): 1.888.856.6613

www.tubeline.ca

Operator's Manual

Keep this manual with the machine at all times.

TL50LSV

Balewrapper

TL50LSV

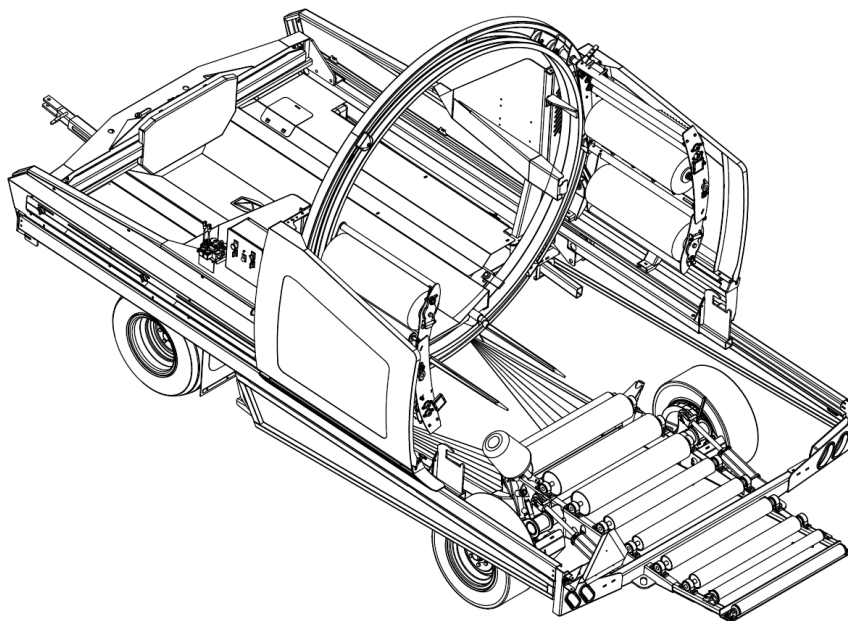

Do not attempt to operate this machine without thoroughly reviewing this manual for safe and proper operation.

Operator's Manual

Thank you for choosing the Tubeline TL50LSV Balewrapper. Our hope is that it will give you many years of productive service. This machine is designed to wrap bales in a continual line with plastic film. Please read and understand this manual and the machine before operating.

Advantages to High Moisture Hay

High moisture hay has many advantages over traditional dry hay.

High moisture hay provides:

- Lower harvesting time
- Cuts to feeding costs
- Increases ADG (Average Daily Gain)
- Minimizes storage loss
- Less reliance on favorable weather.

To learn more about this process visit <http://tubeline.ca/silage.php>

Advantages to Wrapping Bales

Using an inline bale wrapper to protect your product provides a cost and time efficient means of bale storage and limits spoilage of bales.

Serial Number

The implement serial number is located on the front left corner of the frame. (See below) This number helps us to track changes and improvements and must be mentioned when ordering parts or requesting service. For your convenience, a space has been provided inside the front cover of this manual to record the serial number, model number, purchase date, and dealer name.

Model No: _____

Serial No: _____

Date Purchased: _____

Dealer Name: _____

Engine Model No: _____

Engine Serial No: _____

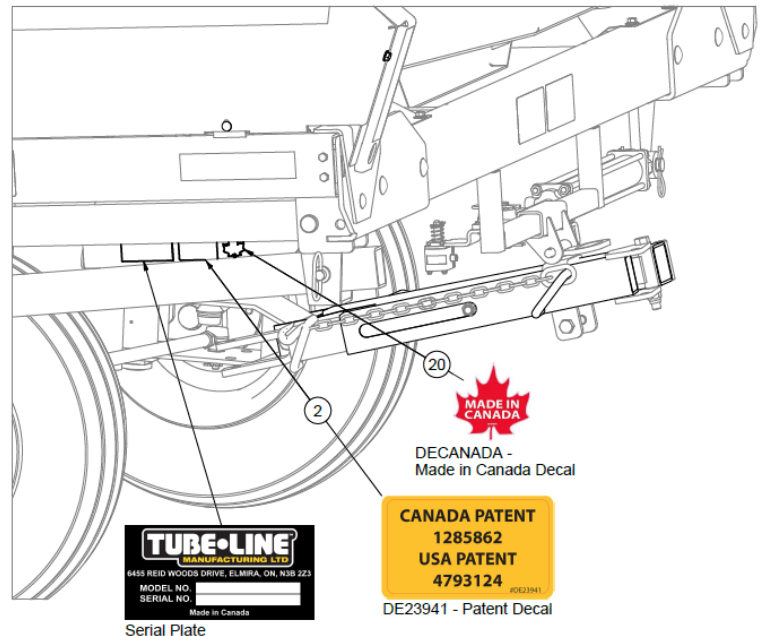



Inline Wrapper 3 Year Limited Warranty Statement *(Excludes Individual Wrapper)*

All Equipment is sold subject to mutual agreement that it is warranted by Tube-Line Manufacturing Ltd (hereinafter the company) to be free from defects in material and workmanship. The company's liability shall be limited exclusively to the original owner to replace or repair without charge, at its factory or elsewhere, at its discretion, any defects in material or workmanship which become apparent in the first year from the date on which the equipment was purchased. In the second and third year the company will supply at no charge replacement of defective parts only. Installation and freight will be at the expense of the owner.

Components supplied by third parties and not manufactured by the company will carry such warranty as extended by such parties, such as but not limited to, tires, batteries, electrical components, hydraulics and engines.

The buyer by the acceptance of the equipment will assume all liability for any damages which may result from accident, abuse or misuse by his employees or others. Any equipment that has been altered or modified without prior written authorization by the company will render the warranty null and void.

No employee or representative of the company is authorized to make changes to this warranty or grant additional warranty terms unless authorized in writing by management of the company.

The company shall not be liable for special, indirect or consequential damages of any kind including but not limited to, loss of revenue, rental replacement costs or other losses.

Normal wear and tear from normal use of the equipment is not warranted. The end user is expected to maintain and service the equipment in accordance with accepted practices. Failure to do so will void the terms of this warranty.

Warranty coverage is null and void unless Warranty Registration form has been completely filled in and is on file at Tube-Line Manufacturing Ltd.

NOTE: Newest manual version can be found at www.tubeline.ca/support

Table of Contents

Operator's Manual	I
Advantages to High Moisture Hay	I
Advantages to Wrapping Bales	I
Serial Number	I
Inline Wrapper 3 Year Limited Warranty Statement (<i>Excludes Individual Wrapper</i>)	II
Section 1: General Information	1-1
Usage	1-1
Suitable Wrapping Timeframe	1-1
Bales	1-1
Wrapping Straw	1-1
Dimensions	1-1
Orientation	1-2
Terminology	1-2
Section 2: Safety	2-1
Safety Signal Words / Safety Messages	2-1
Safety Guidelines	2-1
Personal Protective Equipment	2-2
Lighting	2-2
Safety Decal Locations	2-4
Safety Decal Illustrations	2-5
Section 3: Control Panel	3-1
Control Panel Functions	3-1
Control Panel Functions - Optional	3-2
Section 4: Adjustments	4-1
Door Switch Adjustment	4-1
Bale Ram Limit Switch Functions	4-1
Bale Ram Limit Switch Adjustments	4-2
Plastic Film Installation	4-3
Section 5: Hydraulic Functions	5-1
Flow Control Adjustment	5-1
Directional Control Valve Functions	5-1
Steer Speed Needle Valve Adjustment	5-2
Section 6: Setup	6-1
Dealer Installation	6-1
Battery Hookup	6-2
Pre-Operating Inspection	6-3
Manual Mode Test Run	6-3
Auto Mode Test Run	6-3
Wrapping Site	6-3

Section 7: Operation	7-1
Balewrapper Starting	7-1
Starting a Bale Row	7-1
Auto Wrap Mode	7-2
Steering	7-2
Stopping Cycle	7-2
Optional Remote Start	7-2
Ending Bale Row	7-3
After Wrapping	7-4
Section 8: Transporting Balewrapper	8-1
Transport Lock	8-1
Disconnect Battery	8-1
Fuel Shutoff - 13hp Engine Only	8-1
Power Unit Hookup	8-1
Slow Moving Vehicle (SMV) Sign	8-2
Observe Maximum Transport Speed	8-2
Tire Pressure	8-2
Storage	8-2
Section 9: Feeding	9-1
Feeding from Bale Row	9-1
Plastic Film Disposal	9-1
Section 10: Maintenance	10-1
Grease Points	10-1
Grease Timeline	10-2
Hydraulic Oil	10-2
Hydraulic Oil Filter	10-2
Section 11: Diagnostics	11-1
Control Panel Relays	11-1
Electric Hydraulic Sequence of Operation	11-1
Manifold Port Connections	11-2
Troubleshoot Plastic Film and Carriers	11-3
Section 12: Option - Power Drive	12-1
Power Drive Installation - Hydraulic Control Circuit	12-1
Power Drive Installation - Single	12-2
Power Drive Installation - Dual	12-3
Power Drive Operation	12-4
Section 13: Option - Remote Control	13-1
Remote Control Installation	13-1
Remote Control Function	13-1
Option - Remote Control Start Add-on*	13-2
Remote Start Add-on Installation	13-2
Remote Start Add-on Operation	13-3
Section 14: Option - Plastic Film Sensor	14-1
Film Sensor Installation	14-1
Plastic Film Sensor Adjustment	14-2

Plastic Film Sensor Operation	14-2
Section 15: Option - Wireless Plastic Film Sensor	15-1
Wireless Film Sensor Receiver Board Installation	15-1
Wireless Film Sensor Transmitter Installation	15-2
Wireless Film Sensor Test	15-2
Wireless Film Sensor Operation	15-2
Section 16: Option - Dispatch Arm	16-1
Dispatch Arm Installation	16-1
Dispatch Arm Operation	16-2
Section 17: Option - Guide Roller Kit	17-1
Guide Roller Kit Installation	17-1
Section 18: Option - Night Light Kit	18-1
Night Light Kit Installation	18-1
Night Light Kit Operation	18-1
Section 19: Option - Twin Wrap Kit	19-1
Twin Wrap Kit Installation	19-1
Twin Wrap Kit Adjustments	19-1
Twin Wrap Plastic Film	19-2
Section 20: Option - Laser Guidance System	20-1
Laser Guidance Installation	20-1
Laser Guidance Wiring	20-2
Laser Guidance Adjustment	20-3
Laser Guidance Control Screen Functions	20-3
Main Menu Screen	20-3
Laser L Screen	20-3
Main Menu: Count Bales Screen	20-4
Section 21: Option - Roadflex Suspension Axle	21-1
Suspension Axle Installation	21-1
Imperial Torque Value Chart	VII
Metric Torque Value Chart	VIII

Intentionally Left Blank

Section 1: General Information

Usage

This machine is designed to wrap round bales in a continual row with plastic film.

Suitable Wrapping Timeframe

Use a hard-core baler to make the well-shaped and firm bales necessary for successful wrapping. Bales are best wrapped as soon as possible after baling. If bales are left unwrapped they will sag and lose shape. Heating will start soon after baling and protein quality will be lost. It is desirable to wrap within four hours. In an emergency, the bales can be left 12 to 16 hours.

The Tubeline wrapper makes timely harvest possible by reducing the dependence on the weather. It is much easier to get to wilt silage than to make dry hay. This also extends the working day, as the correct moisture to bale extends earlier and later in the day.

For more information visit <http://tubeline.ca/silage.php>

Bales

The TL50LSV will wrap round bales **up to 6'**. This machine is **NOT** intended to wrap square bales.

Wrapping Straw

Only two layers of plastic are necessary to weather-protect straw with the TL50LSV. Dry straw may be wrapped continually without spaces. Straw with moisture is best wrapped with spaces in the plastic.

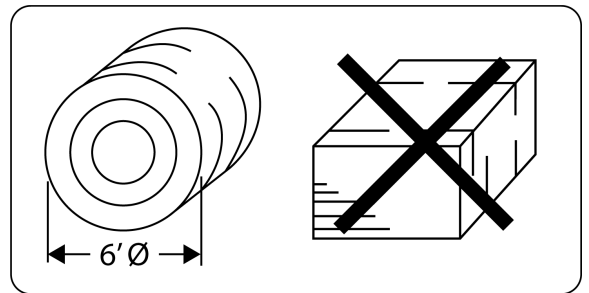

Dimensions

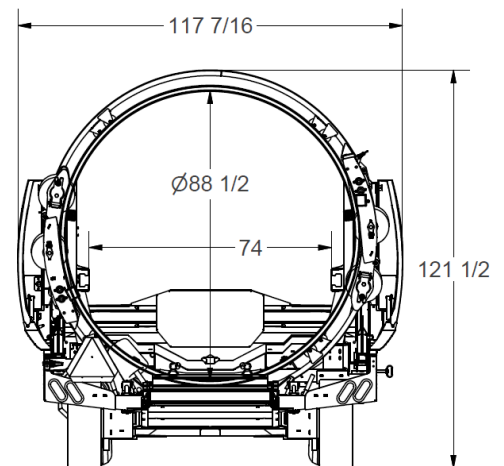
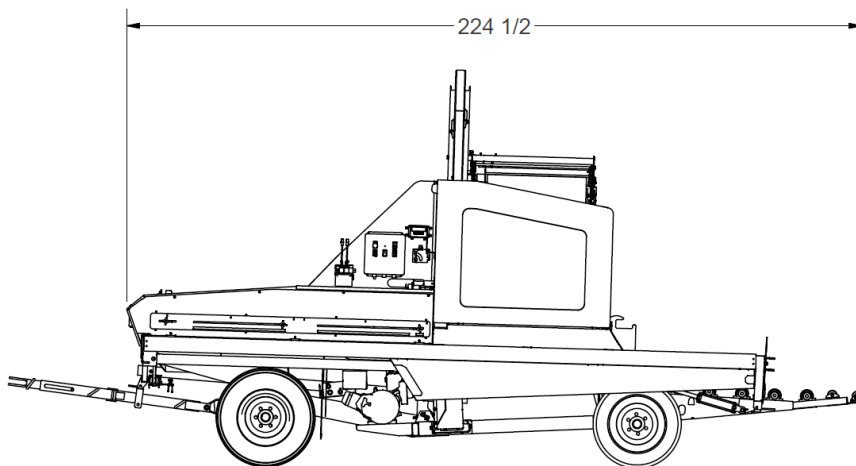

Orientation

Directional references in this manual are dependant on the operator's position from a forward pointed position while towing this machine.

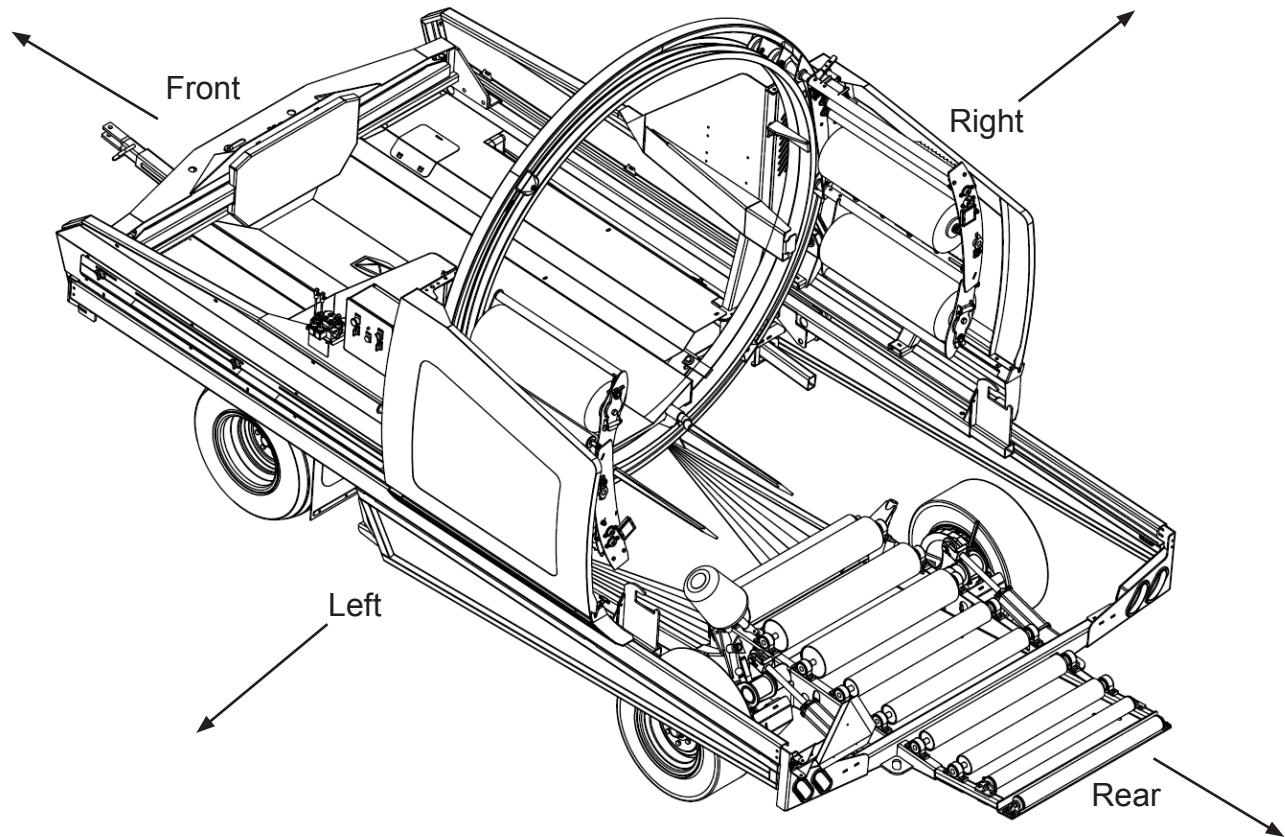

Terminology

Common terms used in this manual.

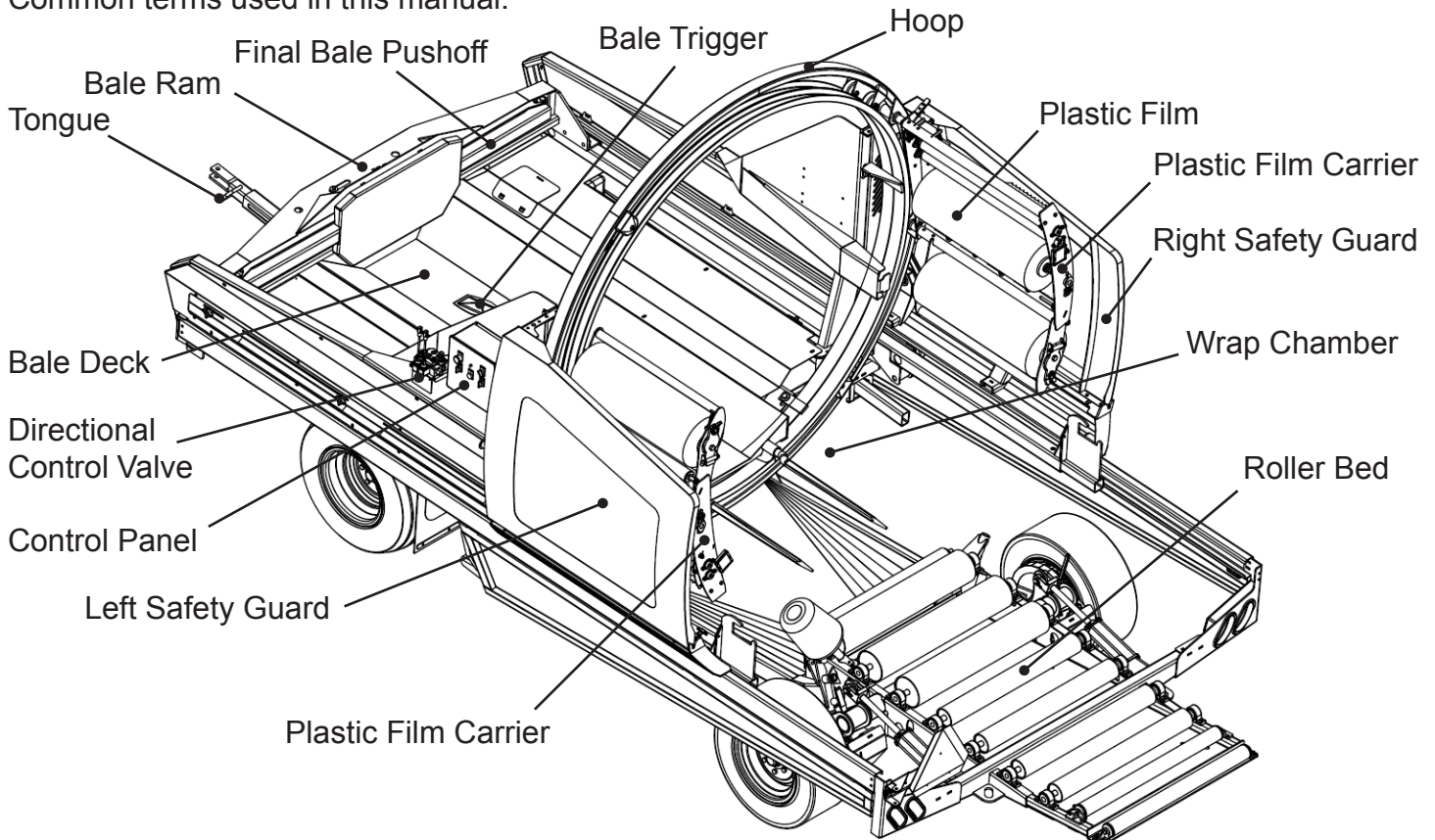

Section 2: Safety

NOTE: This safety alert symbol is found throughout this manual to call attention to instructions involving yourself and others working around the machine.

Failure to follow these instructions can result in injury or death.



This symbol means:

- **Attention!**
- **Become Alert!**
- **Your Safety is involved!**

Safety Signal Words / Safety Messages

CAUTION: Indicates a potentially hazardous situation that may result in injury.

WARNING: Indicates a potentially hazardous situation that could result in serious injury or death.

DANGER: Indicates a hazardous situation that needs to be avoided. Operator needs to be aware of these dangers. High probability of serious injury or death.

NOTE: Indicates an informative non-safety related message.

Safety Guidelines

Take the necessary precautions to avoid injury or death. These include:

- Have training and train new operators.
- Review the safety instructions with all users annually.
- Know where safety decals are and what they convey.
- **DO NOT** paint over, remove or deface any safety signs or warning decals on your equipment.
- Replace damaged and/or missing safety decals.
- **DO NOT** operate without fully installed shields.
- Reinstall any removed shields **BEFORE** operating.
- Inspect machine before operating.
- **DO NOT** operate this machine while under the influence of drugs or alcohol.
- **DO NOT** let children ride or operate this machine.

Personal Protective Equipment



WARNING: Wear work boots, gloves, and safety glasses when maintaining or repairing machine.

WARNING: Wear work boots and ear protection when operating machine.

DANGER: Do not wear loose clothing when operating of maintaining the TL50SLV.



Lighting

This machine is equipped with lights and reflectors as required by the most stringent government and ASAE specifications. They connect to power unit's 7-pin receptacle.

7 Pin Connector Wiring:

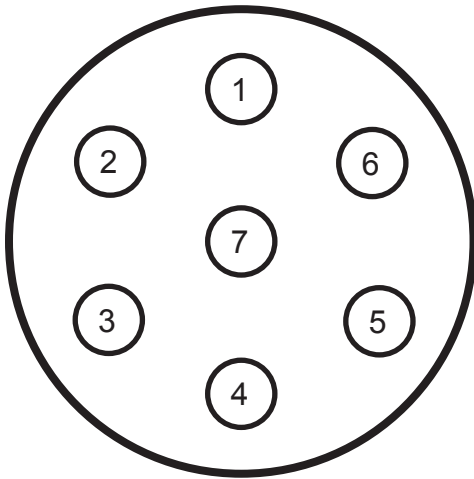

7-Pin Connector Front

PIN	WIRE	FUNCTION
1	White	Ground
2	N/A	N/A
3	Yellow	Amber Running Light / Left Turn
4	N/A	N/A
5	Green	Amber Running Light / Left Turn
6	Brown	Red Brake Lights
7	N/A	N/A

Clearance Markers

Part No: DEAMBER

Part No: DERED

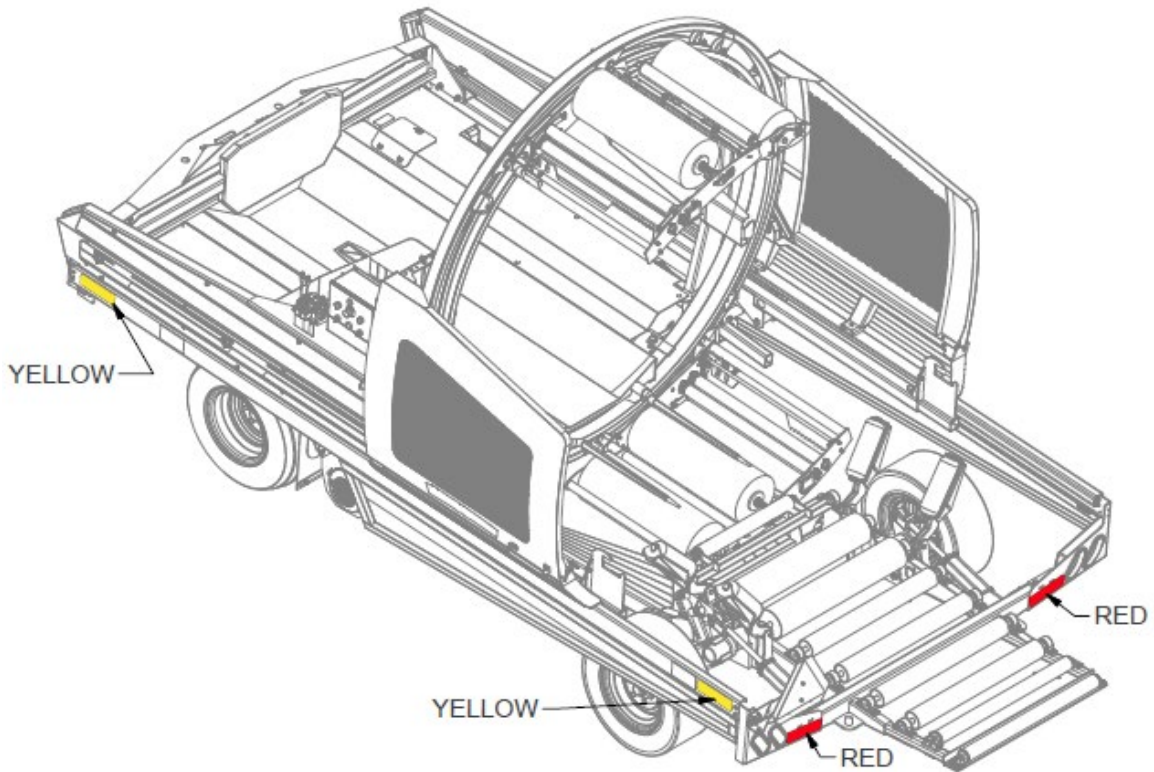
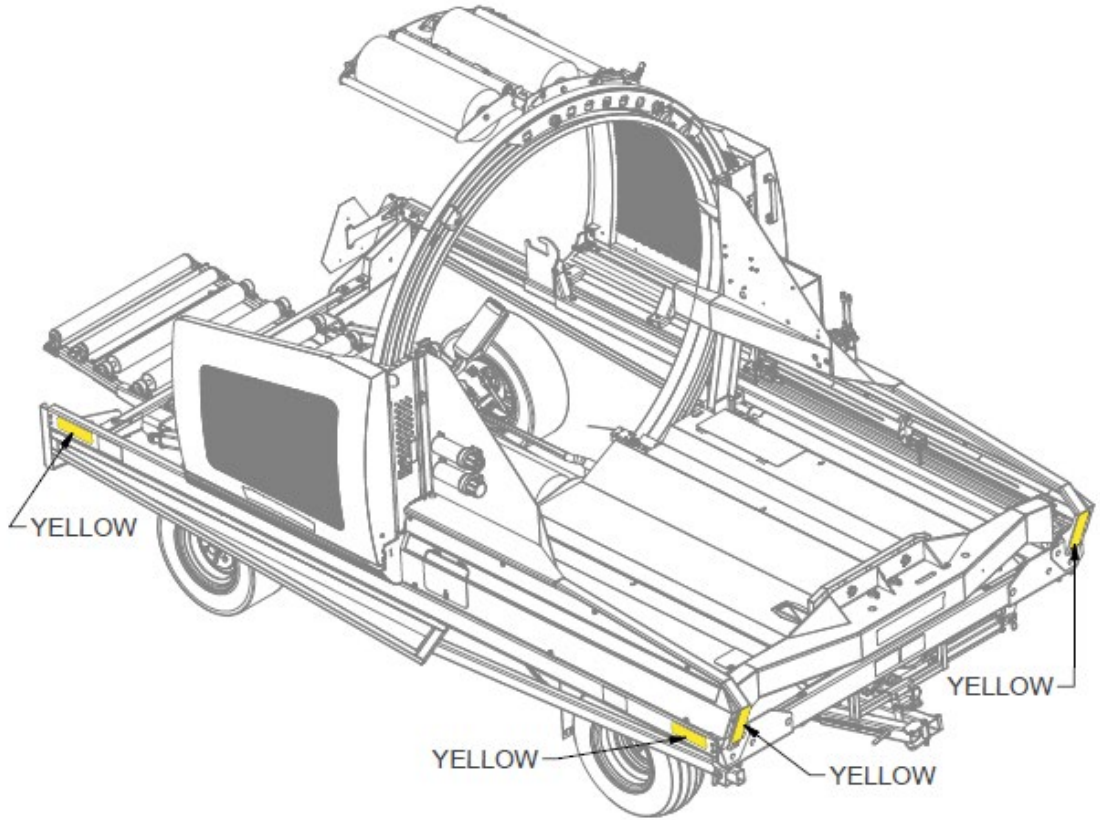
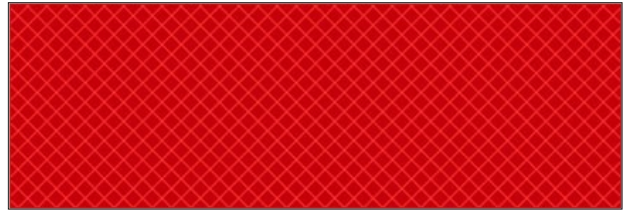
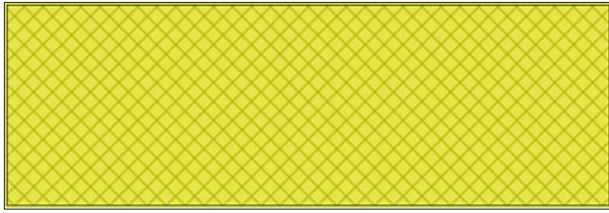

Safety Decal Locations

NOTE: Decals shown are not to scale.

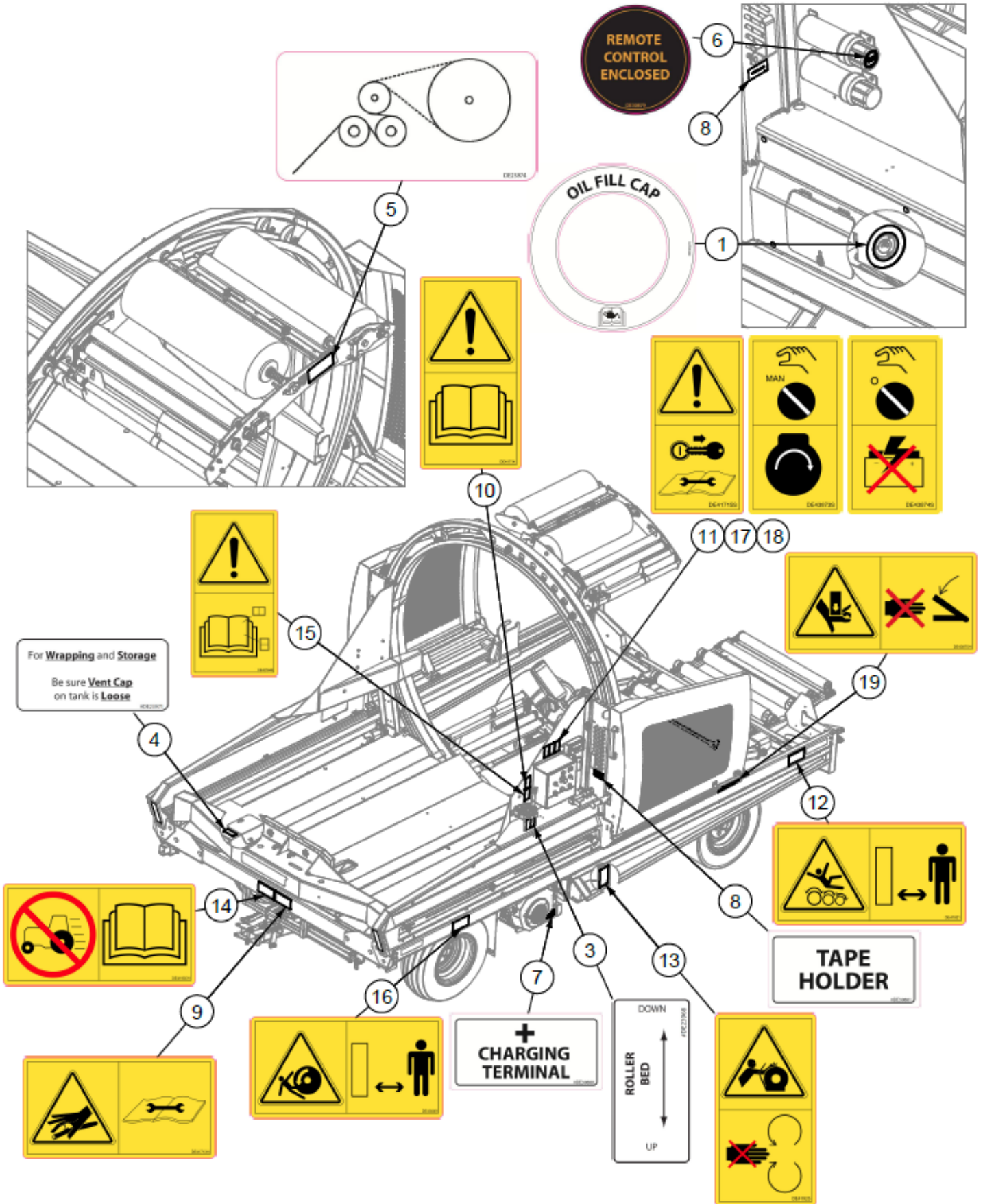

ITEM	QTY	PART NUMBER	DESCRIPTION
1	1	DE30871	Oil Fill Decal
2	1	DE23941	Canada/USA Patent Decal
3	1	DE23968	Roller Bed Decal
4	1	DE23971	Wrapping and Storage Decal
5	2	DE23974	Wrap Instruction Decal
6	1	DE30879	Remote Enclosed Decal
7	1	DE30880	Charging Terminal Decal
8	2	DE30881	Tape Holder Decal
9	1	DE41713H	ISO Decal - High Pressure Fluid Horizontal
10	1	DE41714S	ISO Decal - Read Operator's Manual
11	1	DE41715S	ISO Decal - Remove Key Before Repair
12	2	DE41921	ISO Decal - Do Not Stand on Rollers
13	1	DE41925	ISO Decal - Hoop Wheel Entanglement
14	1	DE41935H	ISO Decal - Transport Speed Limit
15	1	DE42784S	ISO Decal - Read OM Decal Section
16	2	DE43049	ISO Decal - Wheel Crush
17	1	DE43873S	ISO Decal - Engine Start in MAN
18	1	DE43874S	ISO Decal - Panel OFF Before Boosting
19	1	DE43875H	ISO Decal - Hand Crush
20	1	DECANADA	Decal Made In Canada

Safety Decal Illustrations



Part No: DE23941 Item: 2 (See [pg.1](#))
Canada, United States patent information decal.

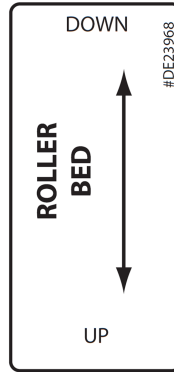
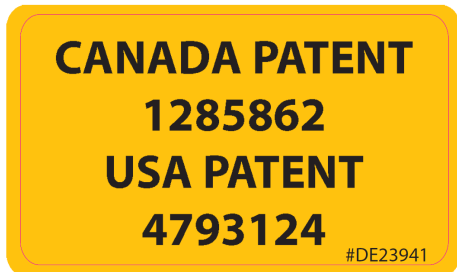

Part No: DE23968 Item: 3

Decal shows hydraulic lever function for raising or lowering the rear roller bed.

Part No: DE23971 Item: 4

Loosen vent cap on top of fuel tank to release any fume build-up.

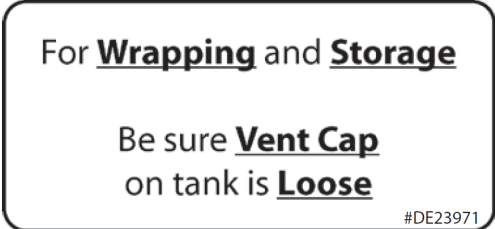

Part No: DE23974 Item: 5

Side view of proper plastic film routing through bale wrap carrier.

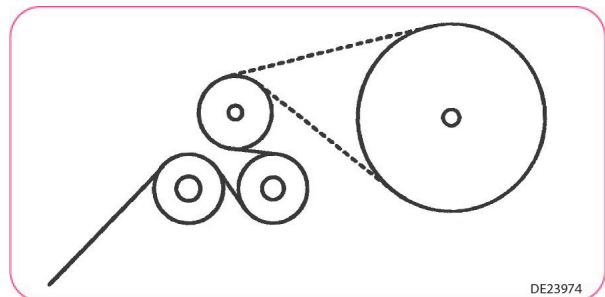

Safety Decal Illustrations

Part No: DE30879 Item: 6

Remote Control Enclosed decal.



Part No: DE30880 Item: 7

Positive charging terminal for use a battery boost.



Part No: DE30881 Item: 8

Wrap tape can be stored on this holder.



Part No: DE41713H Item: 9

Do not use hand to check for hydraulic leaks, alternatively use a piece of cardboard.

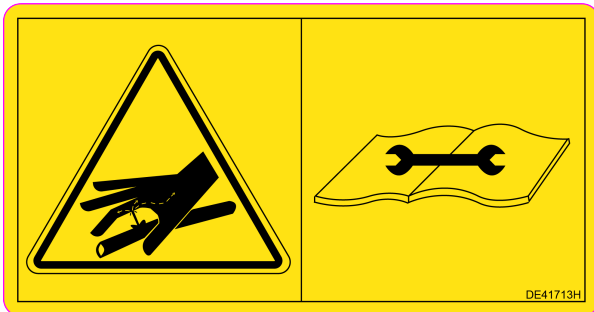

Part No: DE41714S Item: 10 Part No: DE41715S Item: 11

Read this manual and learn the machine functions before attempting to wrap bales.

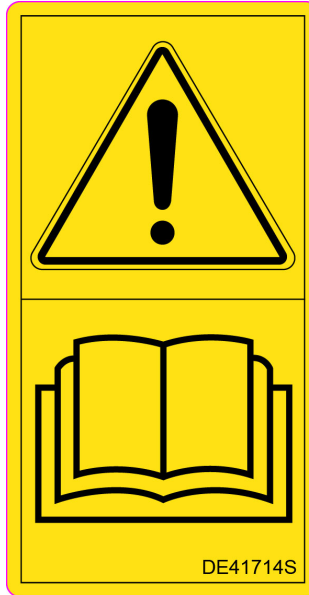

Read this service manual before attempting repairs, remove key from engine before attempting repairs.

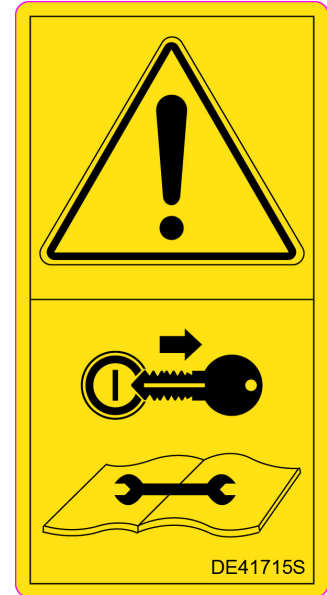

Part No: DE41921 Item: 12

Do not stand on rollers, stand clear of machine while in operation. Use caution when attempting repairs in this area.

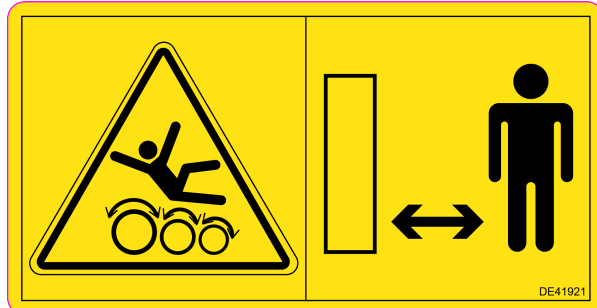

Part No: DE41713H Item: 9

Do not use hand to check for hydraulic leaks, alternatively use a piece of cardboard.

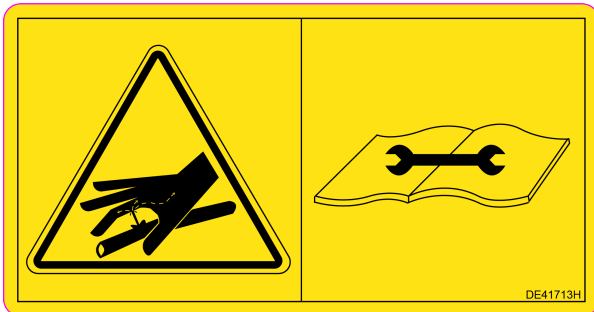

Part No: DE41925 Item: 13

Entanglement hazard, do not remove wheel drive shield while engine running.



Safety Decal Illustrations

Part No: DE41935H Item: 14

Do not exceed top speed of 32km/h (20mph) while transporting this machine.

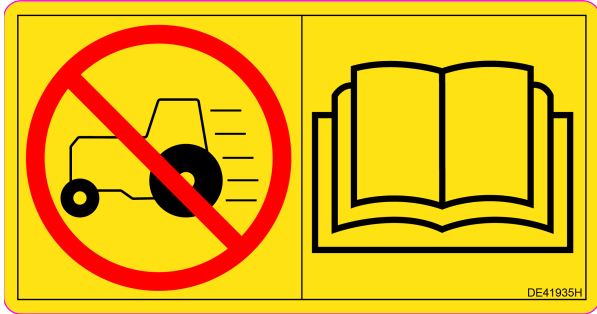

Part No: DE42784S Item: 15

Read the decal section of the operator's manual to understand potential hazards to avoid.

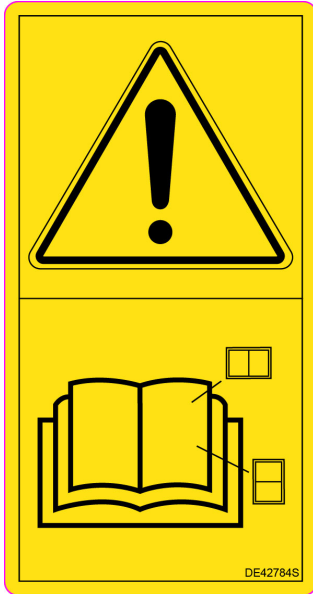

Part No: DE43059 Item: 16

Keep clear of wheels when machine in operation and transportation.

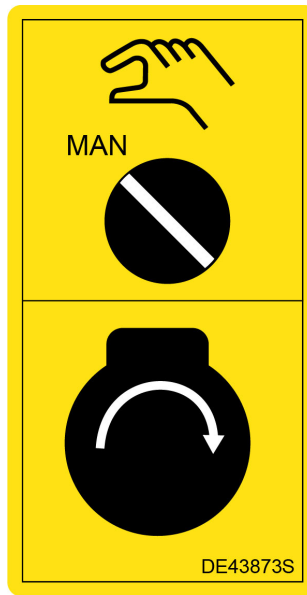
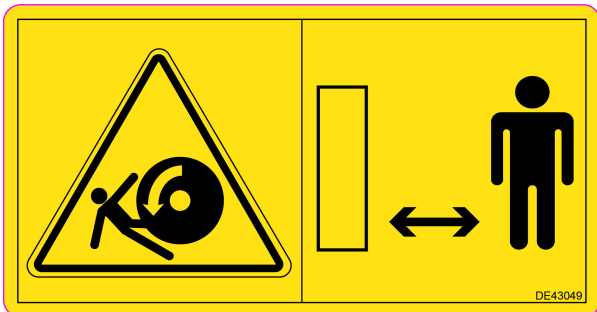

Part No: DE43873S Item: 17

Turn control panel to manual wrap mode (MAN) before starting engine.

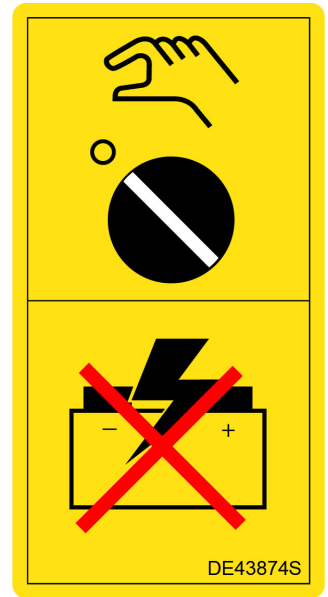

Part No: DE43874S Item: 18

Turn off engine power and control panel before boosting battery.

Part No: DE43875H Item: 19

Use handle when lowering pivoting safety guard to avoid pinching or crushing hands.

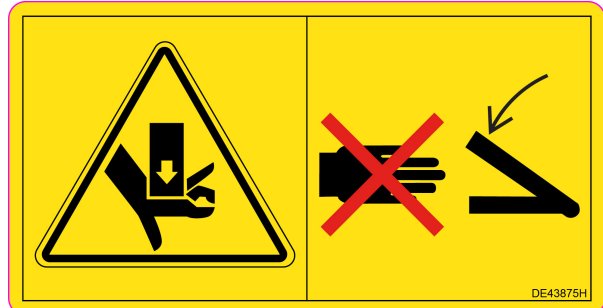

Part No: DECANADA Item: 20 (See pg.1)

Manufacturer of origin decal.



Part No: DE23967 (Req. Powerdrive Option)

Decal shows hydraulic lever function for driving the machine forward or reverse.

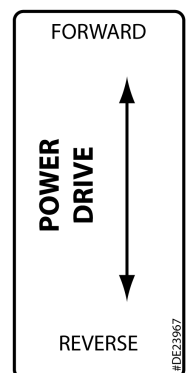

Intentionally Left Blank

Section 3: Control Panel

Control Panel Functions

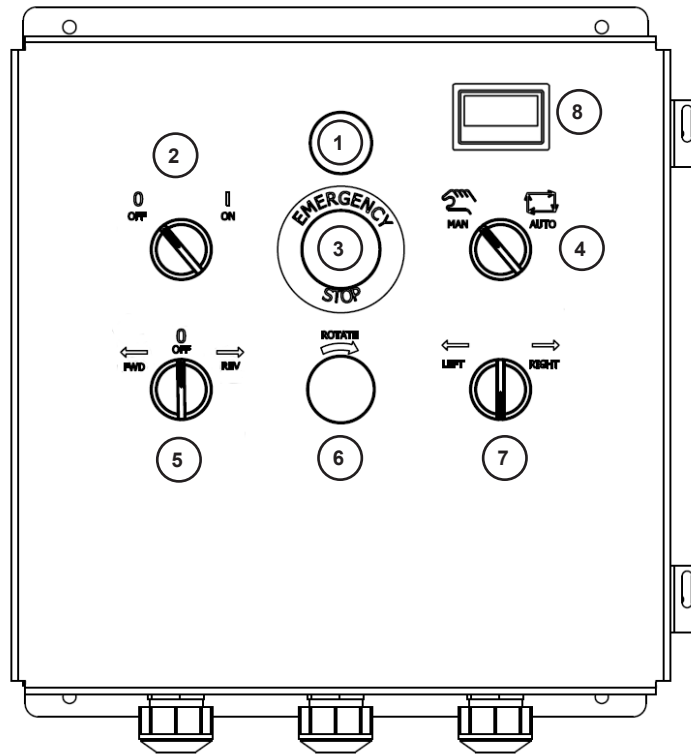

1. Manual Wrap Mode Light

Blinks red to indicate bale wrapper is in manual wrap mode.

2. 2-way ON-OFF Switch

Switch controls panel power. Turn left to cut power, turn right to power on control panel, switch will light up green.

3. Emergency stop Push-Twist Release Knob (E-stop)

Push E-stop knob to cut power to entire bale wrapper, including the engine. Twist knob to end emergency stop.

4. 2-way MAN-AUTO Wrap Mode Switch

Turn switch left to engage Manual wrap mode. Turn switch right to engage Auto Wrap mode.

5. 3-way Center Return Ram FWD-REV Switch

This switch will return to default **OFF** position when released. Turn switch to **REV** (REV = reverse) to move a bale through the wrap chamber in manual wrap mode. Turn switch to **FWD** (FWD = forward) to move bale ram towards front of the wrapper (home position).

6. Hoop Rotate Push Button

In manual wrap mode push and hold button to rotate hoop, applying plastic film to advancing bale.

7. 3-way Center Return LEFT-RIGHT Steering Switch

This switch will return to default neutral position when released. Turn switch left or right to steer the bale wrapper left or right. This function applies to both wrap modes.

Control Panel Functions - Optional

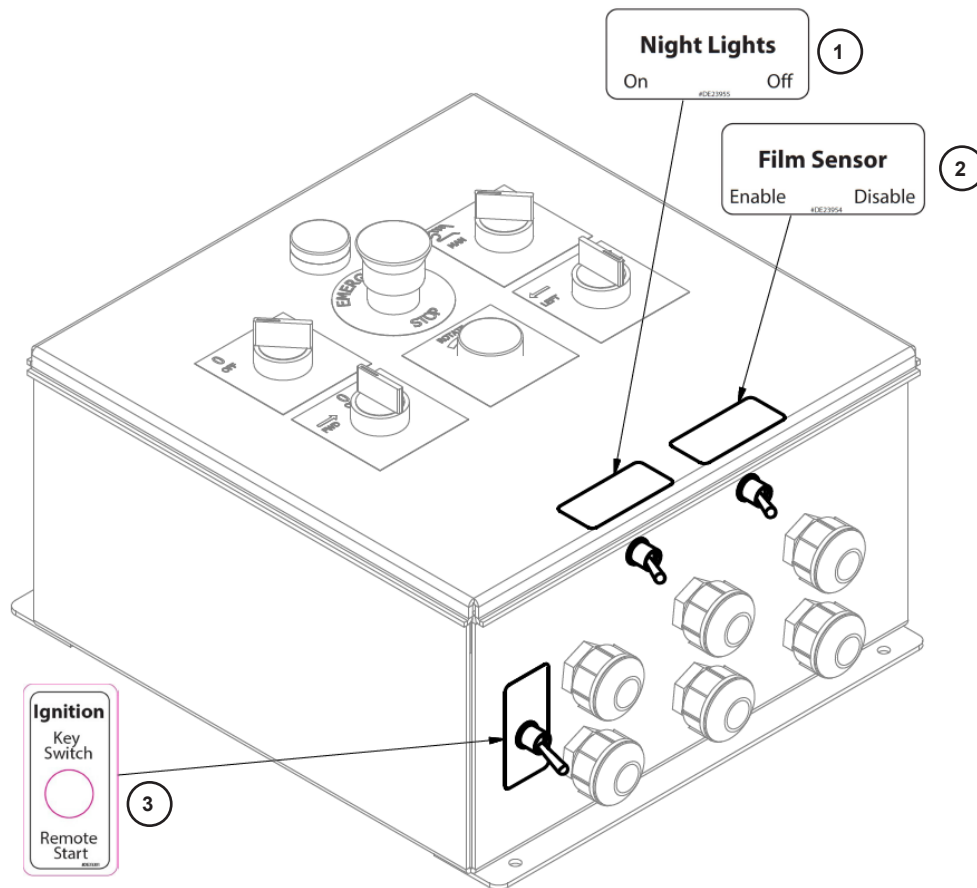

1. Night Light Toggle Switch

Switch toggle to left side to turn on Night Light option, control panel must also be on.

2. Film Sensor Toggle Switch

Switch toggle to left side to enable Film Sensor option, control panel must also be on.

3. Remote Start Toggle Switch

Switch toggle to front position use key switch, disabling Remote Start option or switch toggle to back position to enable Remote Start option (does not disable standard engine key switch start). Control panel must also be on.

Section 4: Adjustments

Door Switch Adjustment

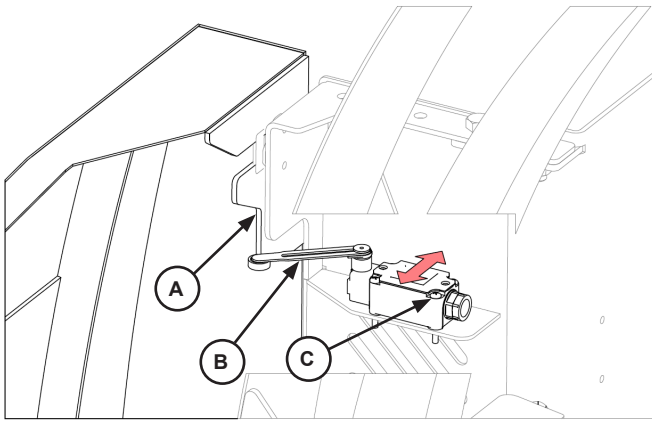

Top tab (A) of left safety guard must be fully closed and contact the door switch arm (B) to engage auto wrap mode. See [Fig. 1](#).

- Loosen 4 machine screws (C) and slide door switch forwards if door switch does not contact left safety guard tab.

Loosen 4 machine screws (C) and slide door switch towards rear of machine if door switch arm contacts safety guard tab before safety guard is fully lowered.

Bale Ram Limit Switch Functions

A. Bale Ram Reverse - Final Pushoff Limit Switch

Returns bale ram to home position when tripped in auto wrap mode. No function in manual wrap mode.

B. Hoop Start Limit Switch

Starts hoop rotation in auto wrap mode when tripped. No function in manual wrap mode.

C. Bale Ram Home Limit Switch

Completes auto bale wrapping cycle by stopping bale ram retract when tripped.

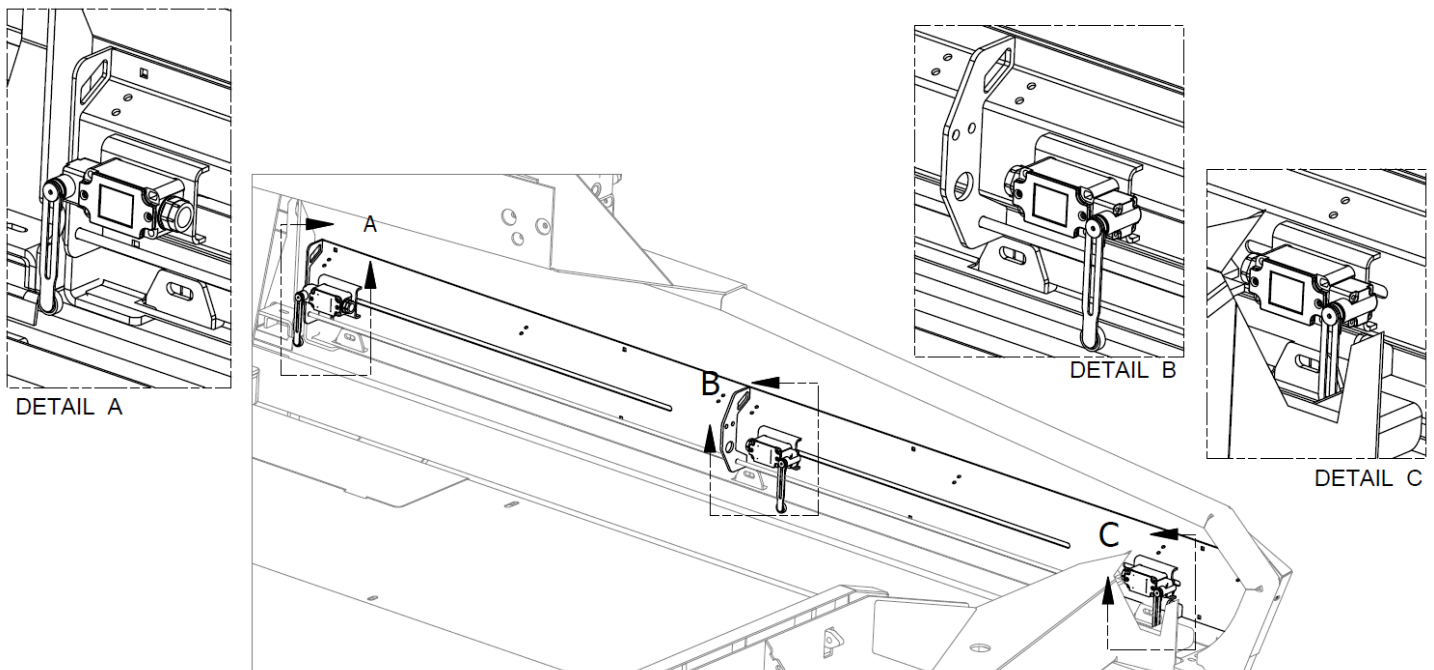

Bale Ram Limit Switch Adjustments

Limit switches can be adjusted to optimize auto wrap mode, allowing for quicker cycles times. To adjust:

- Twist knob towards front to loosen.
- Slide limit switch along its track slot.
- Twist knob towards rear to tighten limit switch.

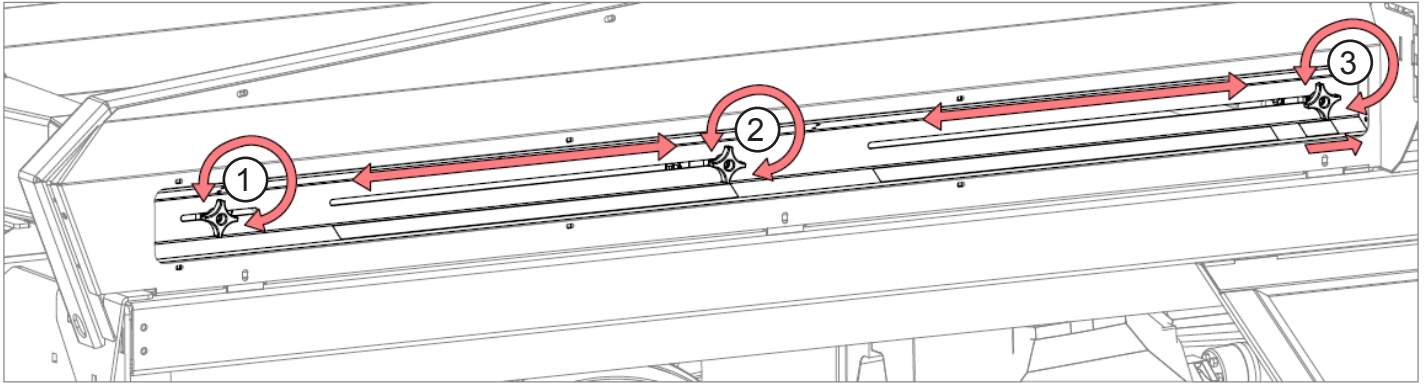

1. Move switch towards front or back to adjust desired bale ram home position. When bale ram returns to this position the engine will idle down. Ram cylinders should not completely retract.
2. Move switch towards front or back to adjust how far bale ram pushes bale through wrap chamber before hoop starts to rotate.
Set to engage as soon as loaded bale contacts bale currently in wrap chamber. This will allow extra plastic film on the joint of the bales before they start moving through the wrap chamber.
3. Move switch towards front or back to adjust how far bale ram extends through wrap chamber before returning to the front home position.
4. Set limit switch to trip when bale joint is halfway through the wrap chamber.
5. Set limit switch to fully extended for final bale pushoff operation, refer to [pg.7-3](#).



Plastic Film Installation

DANGER: Switch control panel to manual wrap mode before changing plastic rolls. Never leave it in auto wrap mode as co-operator may set a new bale on the table or engage wrap cycle with remote.

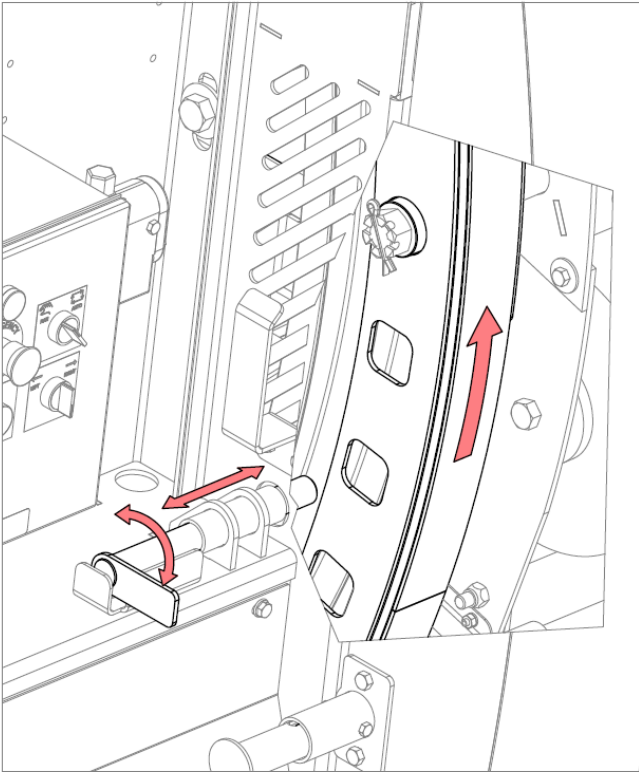

Fig.1

Plastic has a natural tack. In the event of the plastic being stored for an extended period of time the tack may migrate to the opposite side. To test for tacky fold plastic inside to inside and pull apart. Fold opposite way (top to top) to determine tackier side.

The roll of plastic should be installed with the tack against the bales.

The two metal stretcher rolls rotate at different speeds. This causes the plastic to be stretched. Plastic goes over the slow roller first and faster roll second.

1. Rotate hoop manually until empty plastic wrap carrier can be accessed from the left safety guard position. See [Fig.1](#).
2. Lift handle and insert hoop lock pin through hole in hoop to lock plastic wrap carrier to desired height. See [Fig.1](#).
3. Unfasten rubber latch from inner rear of left safety guard. See [Fig.2](#).

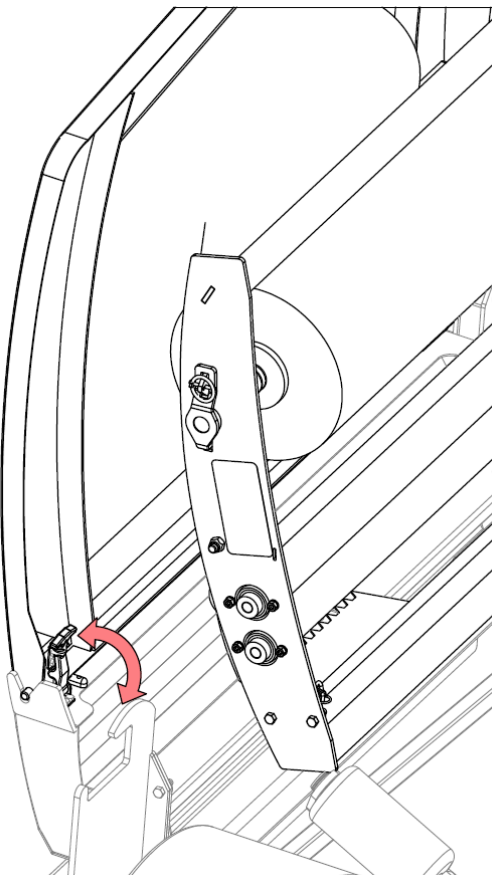

Fig.2

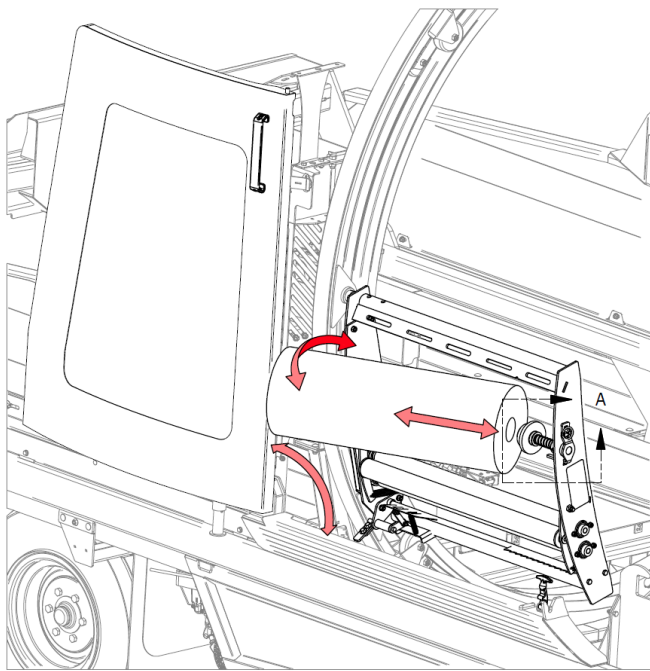
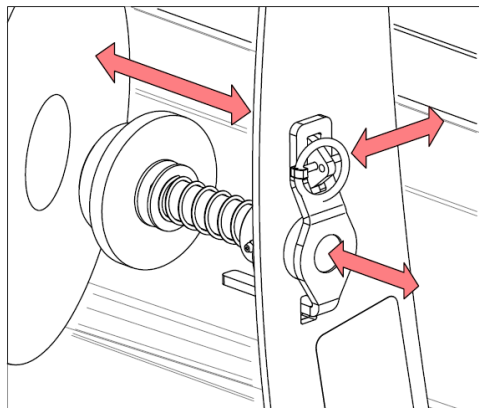

Fig.3

4. Lift left safety guard 90° to open position. See Fig.3.
5. Remove linchpin from rear of plastic wrap carrier. See Fig.4.
6. Remove empty plastic wrap cartridge from plastic wrap carrier by compressing sliding spring spool.
7. Press one end of new plastic wrap roll into sliding spring spool. See Fig.3.
8. Swing free end of plastic wrap roll into plastic wrap carrier, aligning hole over stationary spool.
9. Once aligned the sliding spring spool should snap into locked position.



DETAIL A

Fig.4

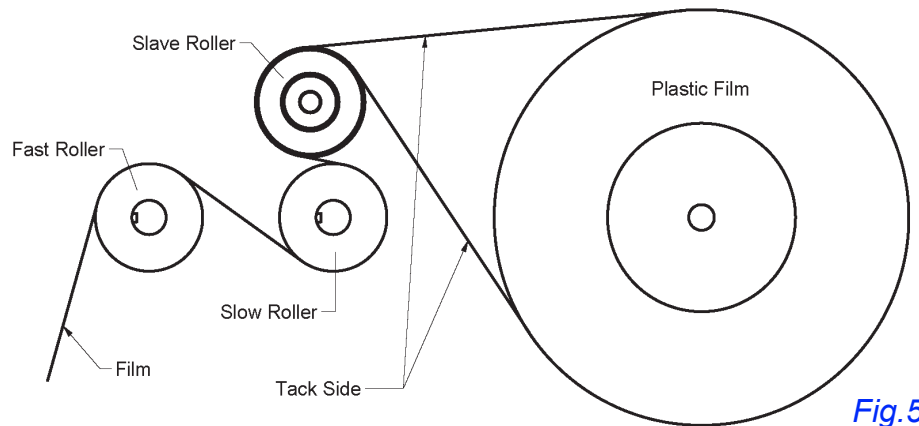

Fig.5

10. Reinsert linchpin through sliding spring spool to secure new plastic wrap roll.
 11. Slide hoop lock pin out of hoop to resume wrap operation. See Fig.1.
 12. Route loose end of plastic wrap roll through 3 bottom rollers as shown in Fig.6 and decal located on rear side of plastic wrap carrier. See Fig.5.
 13. Tie loose end of plastic to bale guide hook.
 14. Close left safety guard, secure with rubber latch.
- NOTE:** Rotate hoop and repeat steps 1-14 if other plastic wrap carrier requires reloading.

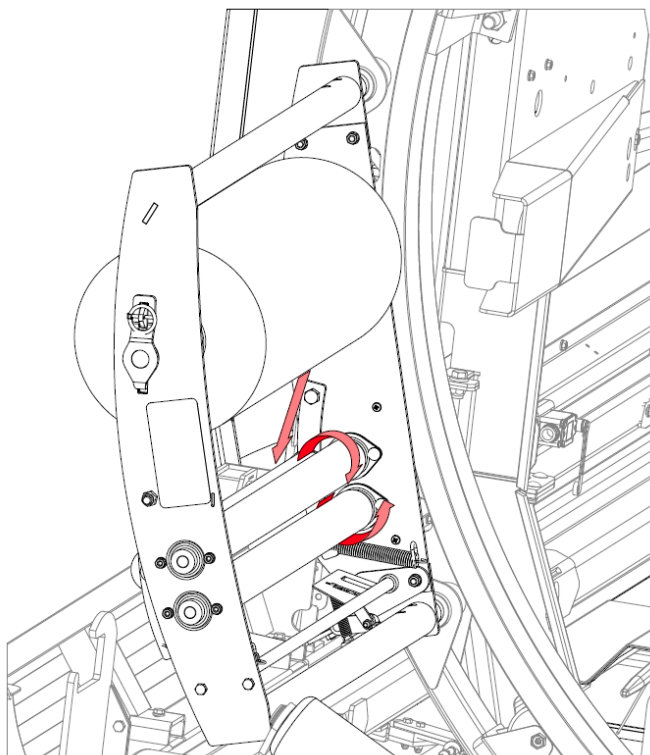
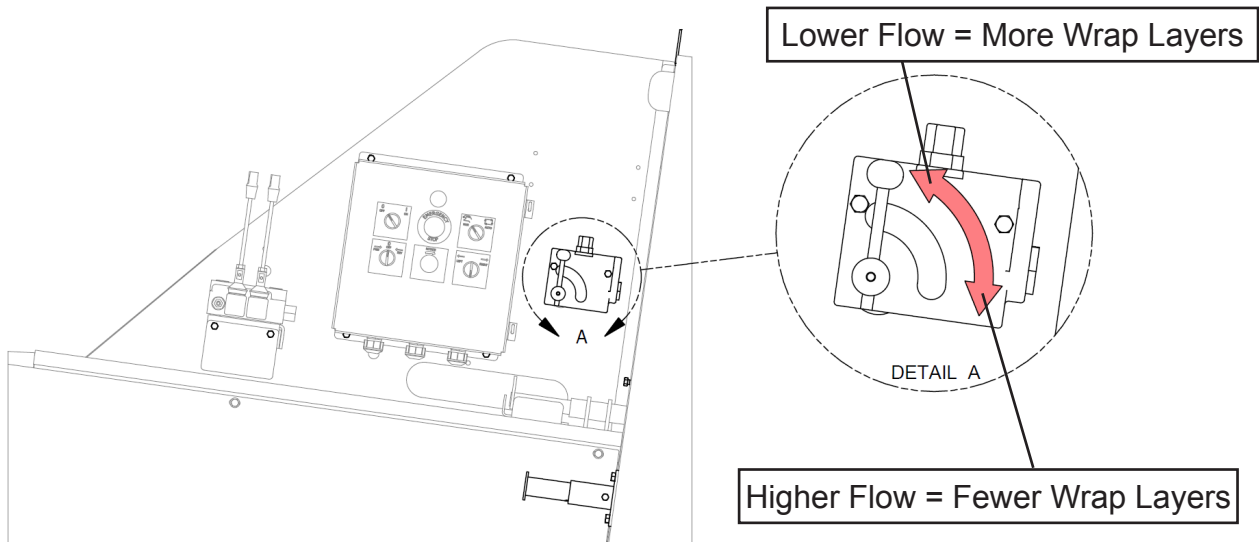

Fig.6

Section 5: Hydraulic Functions

Flow Control Adjustment

The flow control valve located next to the control panel controls the speed of the bale ram. Setting it to a lower flow allows for more plastic film wrap layers per bale, while increasing the flow speeds up the wrap cycle but limits the amount of plastic film wrap layers that can be applied to each bale.



Optional Power Drive FWD-REV

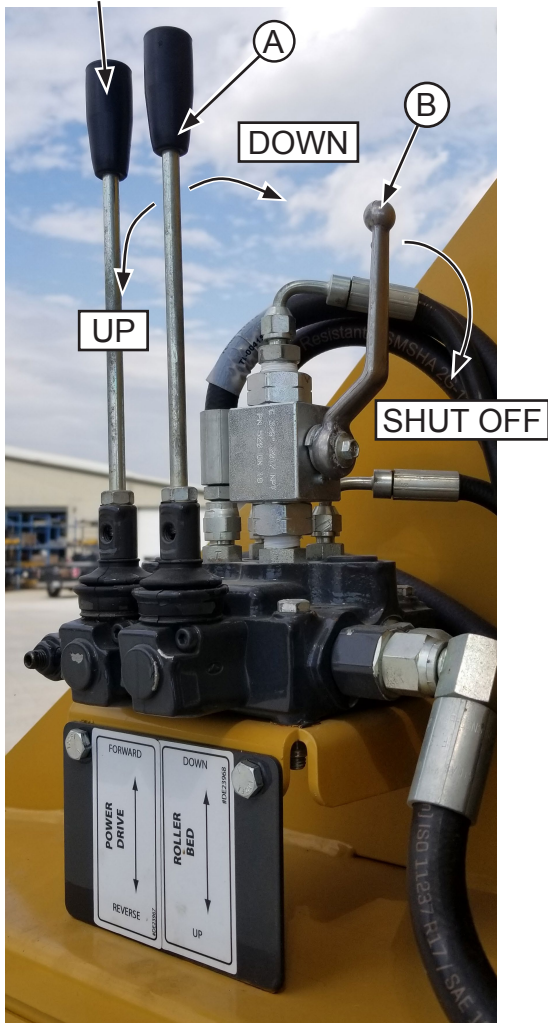

Directional Control Valve Functions

NOTE: Standard directional control valve only has one lever located on side closest to control panel.

- Push roller bed lever **(A)** to lower the rear cam axle which also lowers the roller bed.
- Pull roller bed lever to raise the rear cam axle which also raises the roller bed.
- Pull ball valve handle **(B)** down with roller bed raised to prevent gradual lowering the roller bed.
- Lift ball valve handle to resume hydraulic flow to rear axle cylinders.

NOTE: Refer to [pg. 12-1](#) for Optional Power Drive details.

Fig.1 Shown with optional Power Drive lever.

Steer Speed Needle Valve Adjustment

The needle valve (**A**) is located behind the engine on port P2 of the manifold. It is used to control the speed of steering.

- Rotate right to restrict hydraulic flow which slows the steering speed.
- Rotate left to allow more hydraulic flow, speeding up steering.

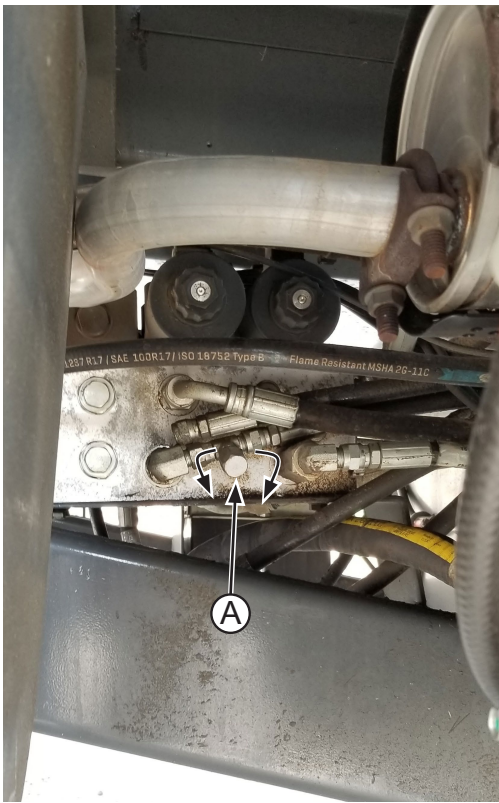

Section 6: Setup

Dealer Installation

Upon delivery the following parts will need to be installed to make the TL50LSV field ready:

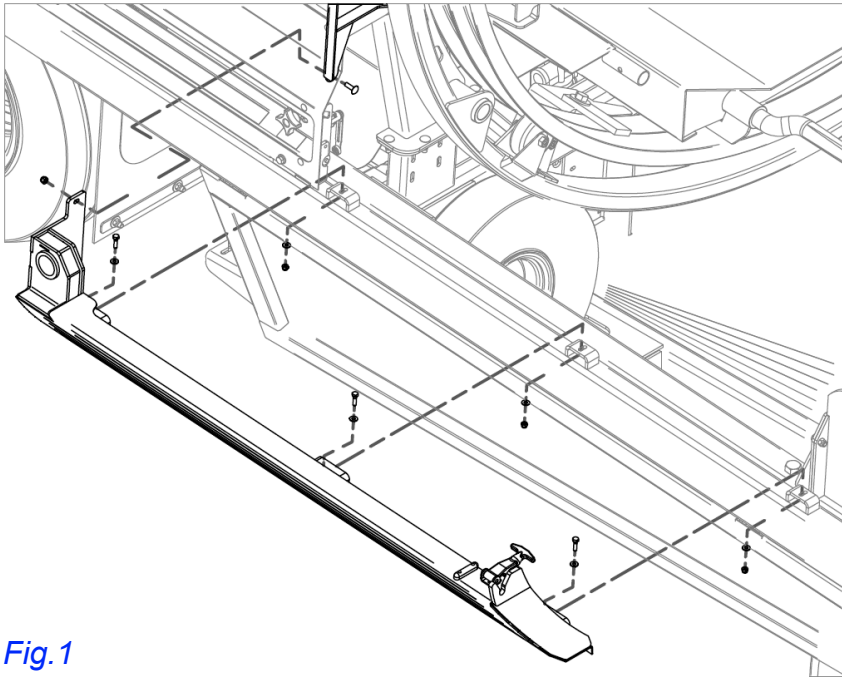

Fig.1

1. Refer to [Parts Manual](#) to ensure all hardware and parts have been delivered.
2. Remove all banded parts from either bale deck or roller bed.
3. Install bottom safety guard mounts using bolts, washers and nuts. Left side shown in [Fig.1](#), right side is the same.

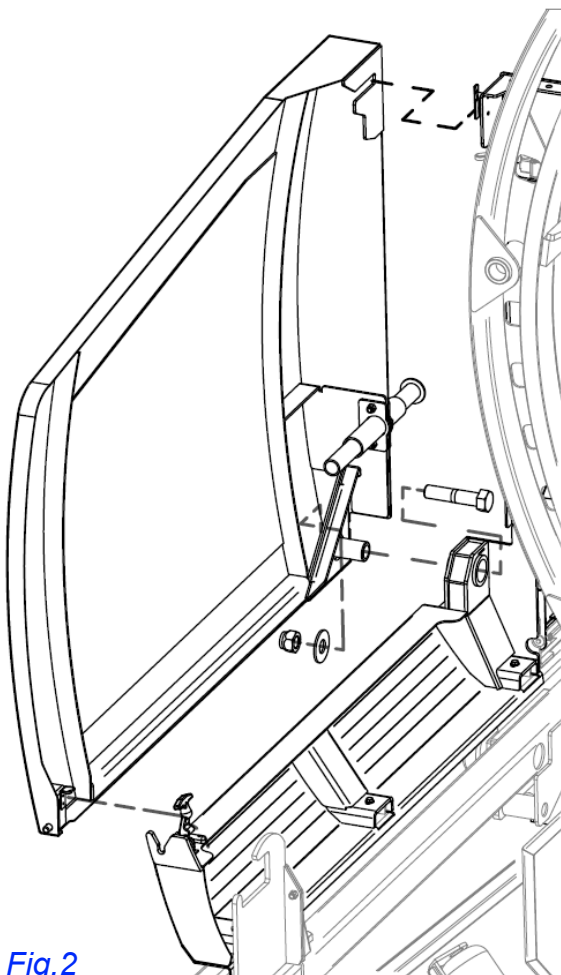

Fig.2

4. Install left safety guard by bolting at pivot point. Do not over tighten. See [Fig.2](#).
5. Close pivoting left safety guard top slot over safety guard mount hook.
6. Check left safety guard range of motion.
7. Lock rubber latch at rear of safety guard.
8. Ensure door switch contacts left safety guard when in closed position. Refer to [Adjustments, pg.4-1](#).

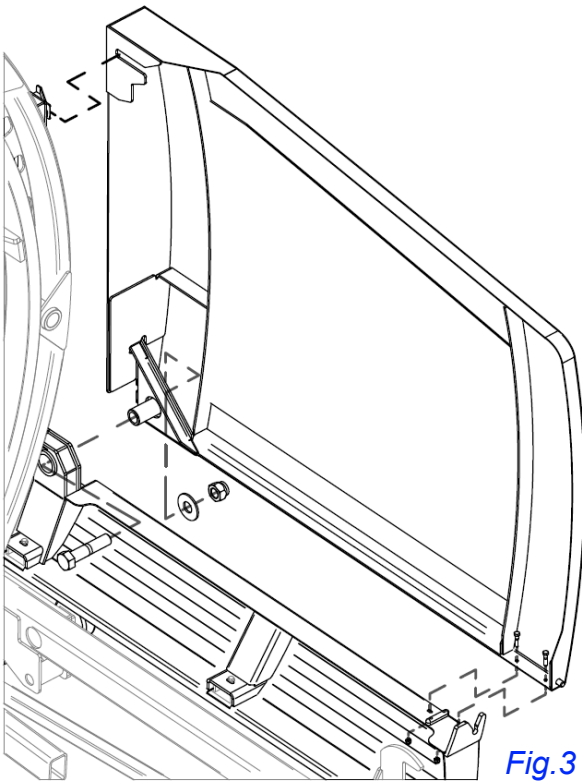

Fig.3

9. Install right maintenance safety guard by bolting at pivot point. Do not over tighten. See [Fig.3](#).
10. Close right maintenance safety guard top slot over safety guard mount hook.
11. Bolt rear of safety guard with bolts and lock nuts.
12. Install Dispatch Arm option, if applicable. Refer to [pg.14-1](#).

Battery Hookup



Fig.1

TL50LSV bale wrappers are shipped with the battery disconnected for safety reasons.

1. Locate battery at middle right of balewrapper. See [Fig.1](#).
2. Reconnect by simply bolting unhooked positive (+) red cable to its matching battery terminal (**A**).
3. Confirm TL50LSV's functions are working properly. Refer to [Control Panel Functions, pg.3-1](#).

Pre-Operating Inspection

Before wrapping at a new site:

- Check oil tank level. Fill to 1/4" from top of sight gauge.
- Check gas tank level.
- Check Tire Pressure.
- Complete a walk around inspection.
- Check engine for hazardous flammable material buildup.
- Check guarding is secure.

Manual Mode Test Run

Test machine in Manual wrap mode without bales and without plastic film rolls installed.

1. Start engine, refer to [Balewrapper Starting, pg.7-1](#).
2. Turn on control panel, refer to [pg.3-1](#).
3. Advance bale ram towards hoop chamber by turning FWD-REV control panel switch to **REV**.
4. While holding bale ram switch in **REV**, engage Hoop Rotate button to test hoop rotation speed.
5. Release REV bale ram switch and Hoop Rotate when bale ram reaches fully extended position.
6. Return the bale ram to front of bale wrapper ("Home" position) by turning **FWD-REV** bale ram switch to **FWD** (forward).

Auto Mode Test Run

Test machine in Auto mode without bales and without plastic film rolls installed.

1. Switch control panel to auto mode, refer to [pg.3-1](#).
2. Press the bale trigger using a pole inserted between the bale ram and the bale deck.



DANGER: DO NOT attempt to engage the bale trigger by hand.

3. The TL50LSV balewrapper should automatically follow the sequence of the manual wrap mode without the manual operation of the control panel.

Wrapping Site

- Select a site that will allow room to make an adequate bale row length.
- Site should be free of grass and debris which can attract rodents that damage plastic film.
- There should be space for at least 50 bales in a row.
- Select a site that is accessible in winter conditions and does not flood in the spring.
- Avoid soft ground, as the wrapper will not move forward smoothly if it is sinking into the ground.
- Wrap on level ground or a slight uphill grade for best bale row compaction.

Intentionally Left Blank

Section 7: Operation

Balewrapper Starting

Fig.1 20hp shown.

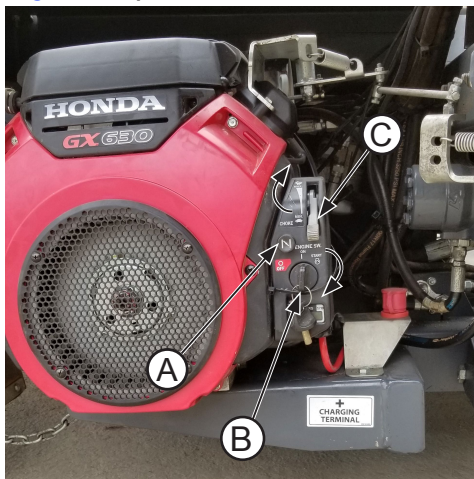

1. Read engine manual to familiarize yourself with its functions.
2. Choke **(A)** engine if cold starting.
3. Turn engine key **(B)** to START until engine runs. Do not hold more than 5 seconds.
4. Slowly throttle **(C)** engine as it warms up.
5. Switch control panel on and select manual wrap mode, refer to [pg.3-1](#).

Starting a Bale Row

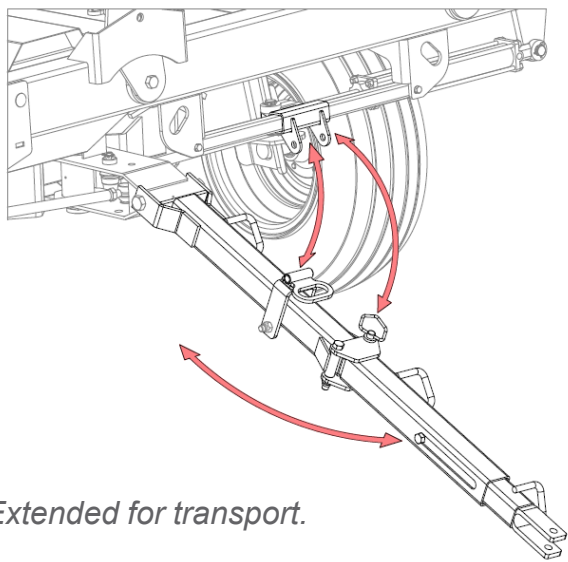

Extended for transport.

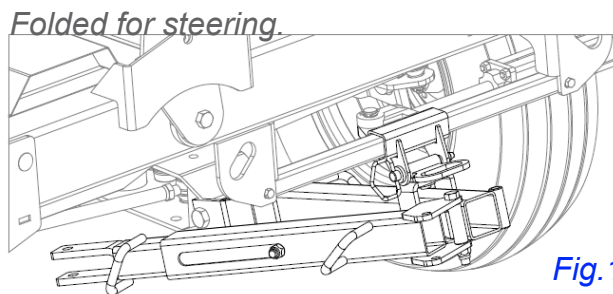

Folded for steering.

Fig.1

1. Place wrapper at start of desired row.
1. Disengage transport lock, see [pg.8-1](#).
2. Raise rear cam axle with directional control valve. See [pg.5-1](#).
3. Fold tongue and pin to steering slider tube. See [Fig.1](#).
4. Confirm balewrapper is steering straight.
5. Place several unwrapped bales at end of row to act as stop, thus creating compacted bale row.
6. Lift first bale to height that will allow endcap to be placed over end of bale.
7. Place first bale onto bale deck.
8. Run first few bales through wrap chamber using manual mode and with the rear cam axle raised. See [Fig.2](#).
9. Adjust limit switches using first bale as a gauge on current job's bale size.
10. Lower rear cam axle to ground before engaging auto wrap mode.



Fig.2

Auto Wrap Mode

1. Switch balewrapper control panel to auto wrap mode. Refer to [pg.3-1](#).
2. Use lifting machine to set bales on the bale deck. Bales must be placed on top of bale trigger to start the auto wrap cycle.
3. As bale ram returns to front of balewrapper continue placing bales onto bale deck until reaching the last bale of row.

Steering

The TL50LSV balewrapper is equipped with electric over hydraulic steering to keep the balewrapper headed in desired direction or to direct the wrapper around obstacles. For steering operation refer to [Control Panel Functions, pg.3-1](#).

CAUTION: Wrap on flat even surface to prevent balewrapper from drifting out of line.

NOTE: Prevent air pockets in bale row by avoiding sharp turns.

NOTE: Steering speed can be adjusted with the needle valve at the manifold block. Refer to [Hydraulic Functions, pg.5-2](#).

Steering can be done remotely with optional remote control. Refer to [pg.12-1](#).

Manual steering is not required with optional laser guidance system. Refer to [pg.18-1](#).

Stopping Cycle

If a problem occurs after the cycle has started in automatic wrap mode, turn **AUTO-MAN** control panel switch to **MAN**. Refer to [pg.3-1](#).

Press control panel emergency stop to completely shut down balewrapper. Refer to [pg.3-1](#).

Optional Remote Start

Push the **STOP** button on the hand unit to stop the cycle. After the problem is rectified, finish the rest of the cycle in the manual wrap mode and then return to auto wrap mode. If you press start button on the hand unit it will also start the ram forward again but if the ram has passed the hoop start switch the hoop will not start with the ram. Refer to [pg.12-2](#).

Ending Bale Row



Fig. 1

1. Switch balewrapper control panel to manual wrap mode. Refer to [pg.3-1](#).
2. Move bale ram return limit switch to end of slot.
3. Lift last bale to height necessary to place end cap on side facing front of bale wrapper.

NOTE: If placing last bale on wrapper with forked implement tape puncture holes to avoid bale spoil.

4. Place last bale on bale deck and manually push and wrap bale. See [Fig.1](#).
5. Stop the ram and wrap several more layers on the end of the bale.

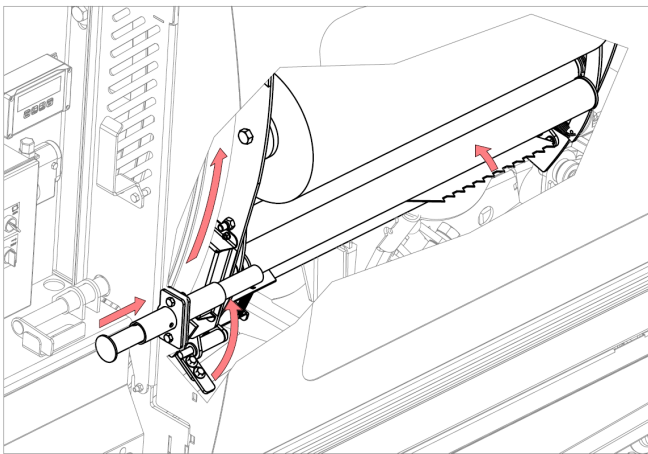

Fig.2

6. Cut plastic film by pressing and holding the film snap while rotating the hoop. See [Fig.2](#).
7. Push last bale to end of bale ram stroke.
8. Return bale ram to front home position.
9. Lift ram home latch from locked position. See [Fig.3](#).
10. Extend the final bale pushoff by pivoting the handle under the ram to the opposite side of the machine. See [Fig.4 & 5](#).

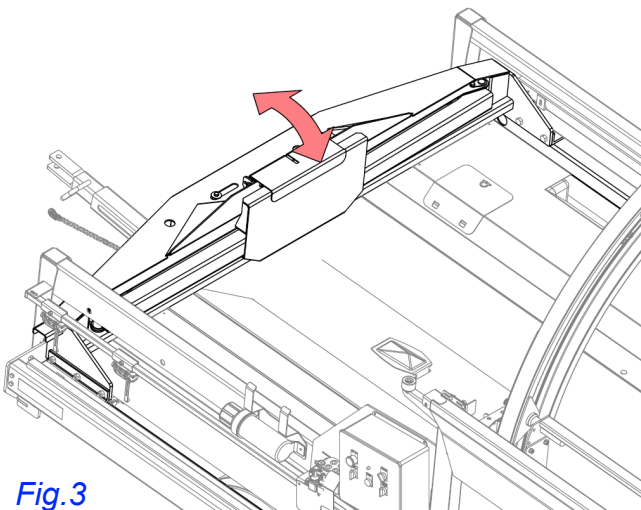

Fig.3

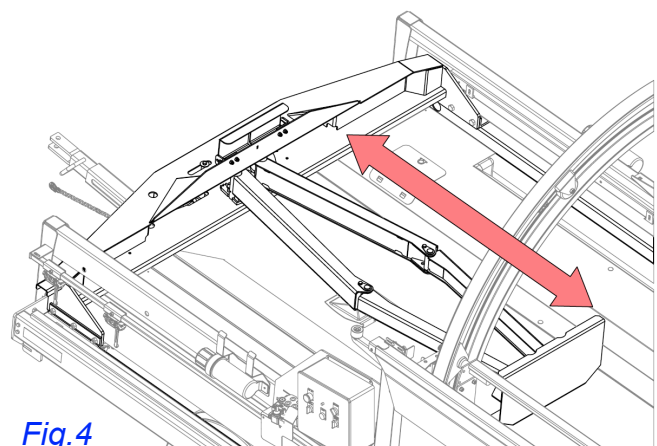

Fig.4

Fig.5

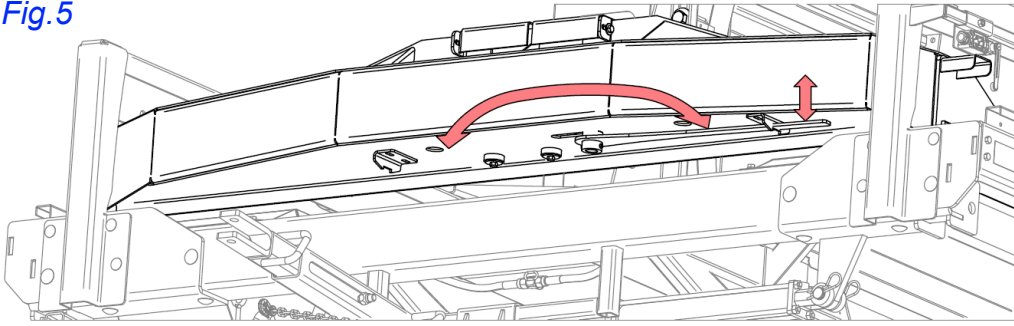
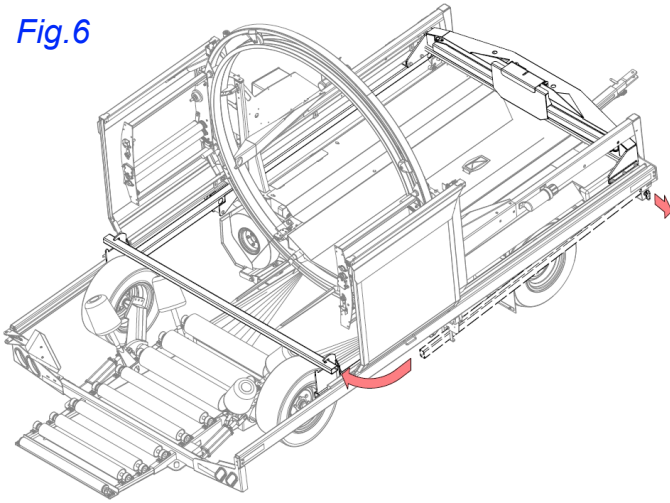

Fig.6



11. Move the bale row through the wrap chamber and onto the roller bed using the REV switch. Refer to [pg.3-1](#).
12. Retract the bale ram to front home position by pressing the forward button on the control panel.
13. Return final bale pushoff to closed position using handle under ram.
14. Flip ram home latch down over bale ram plate.
15. Open the safety doors, remove 2 x 3 tube from its mounts on right side of the wrapper and lay it across the top of the pushoff hooks. See [Fig.6](#).

NOTE: Replace the pin in holder to avoid losing it.

16. Run the bale ram once more to completely push bales free of bale wrapper tail.

17. Open the safety doors, remove and store the 2 x 3 tube in storage brackets. Secure at front with lock pin.

NOTE: Bale wrappers equipped with optional dispatch arm do not require 2 x 3 tube. Refer to [Dispatch Arm Operation pg.14-2](#).

After Wrapping

Inspect wrapped bale row for any holes on plastic film. Patch with tape if necessary. Label bale row with information such as wrap date, moisture percentage, foliage type, etc.

Section 8: Transporting Balewrapper

Transport Lock

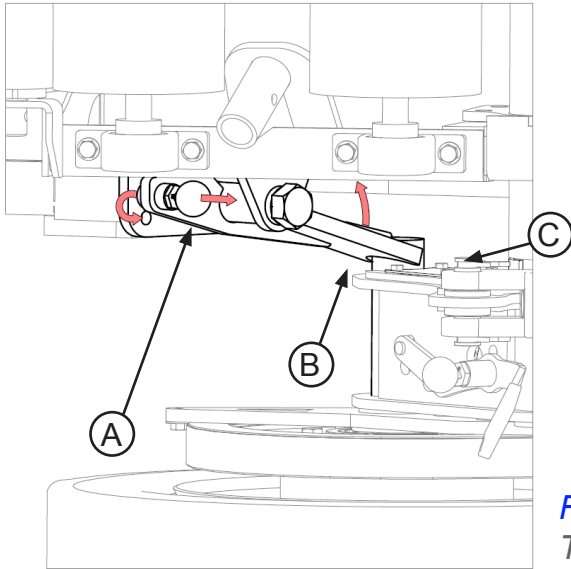

- Raise rear cam axle. Refer to [Directional Control Valve, pg.5-1](#).
- Engage transport lock by lifting spring pin (A) and swinging lock arm (B) over transport lock shaft (C). See [Fig.1](#).

Fig.1

Transport lock shown in locked position.

Disconnect Battery

Disconnect positive (+) red cable from battery located on right side of machine. Refer to [pg.6-1](#).

Fuel Shutoff - 13hp Engine Only

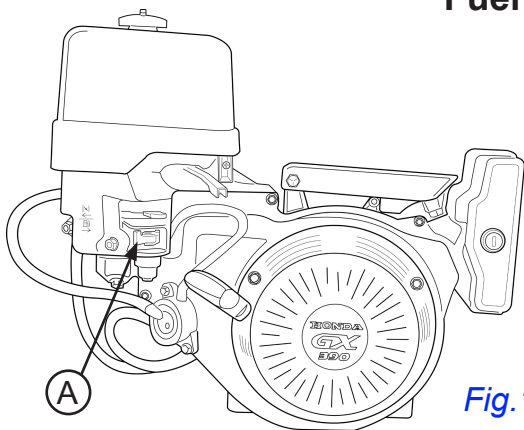

Fig.1

DANGER: Balewrappers equipped with 13hp Honda GX390 engine must have fuel valve (A) shutoff before transporting to avoid fuel spillage and engine damage. See [Fig.1](#).

Power Unit Hookup

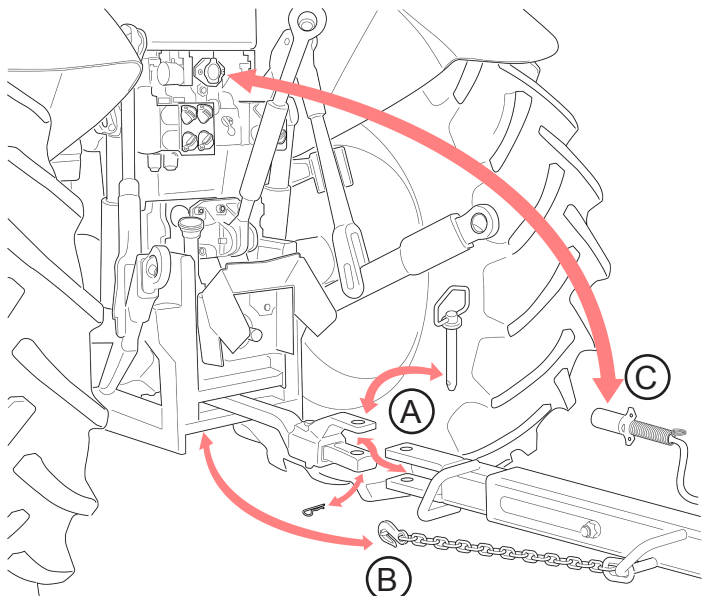
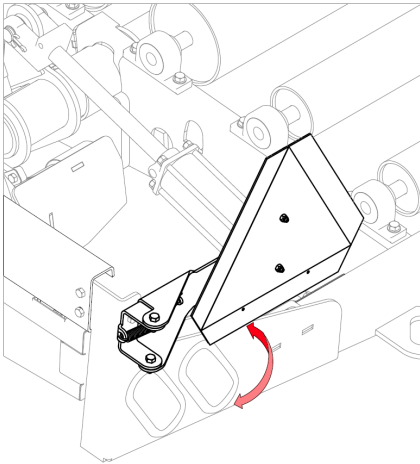

Fig.1

- Undo steering, unfold tongue and insert lock pin.
- Hitch tongue (A) to power unit drawbar with pin.
- Fasten safety chain (B) securely to power unit.
- Insert balewrapper's 7-pin connector (C) into power unit's matching receptacle. Refer to [Lighting & Marking, pg.2-2](#).
- Make sure parking brake is released before driving away.

Slow Moving Vehicle (SMV) Sign



Swing SMV sign back into closed rear facing transport position if it has been flipped out during wrapping operation.

Observe Maximum Transport Speed

The maximum transport speed for this implement is 32 km/h (20 mph).

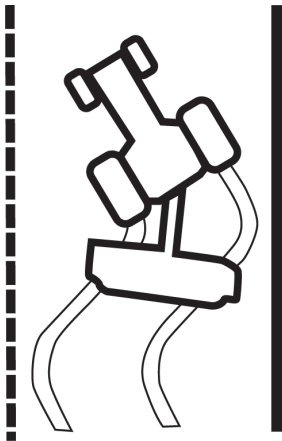

DANGER: Exceeding the implements maximum transport speed can result in:

- Loss of control of the tractor/implement combination.
- Reduced or no ability to stop during braking.
- Implement tire failure.
- Damage to the implement structure or its components

WARNING: Reduce speed when towing under adverse surface conditions, when turning, and when on inclines. Do not attempt transport if the fully loaded implement weighs more than 1.5 times the weight of the tractor.

DANGER: Do not allow riders on machine while transporting or operating.

DANGER: Do not climb on the bale deck or inside the wrap chamber while engine running.

Tire Pressure

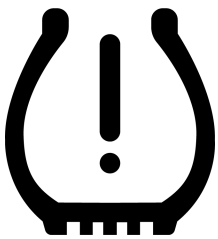

- Maintain proper tire pressure of 36 psi at all times.
- Do not over fill.
- Replace tires with same type if possible, or with same outside diameter.

Storage

- Extend the longevity of your machine store in sheltered area out of the elements and on a flat surface.
- Chock wheels after parking.
- Refer to [Maintenance Section](#) for recommended service and maintenance
- Cover balewrapper if necessary or preferred.

Section 9: Feeding

Feeding from Bale Row

Plastic film wrap will break away from bale row without cutting when removing bales. Remove any remaining plastic film from bale before placing into your feeder or feed area.

In general, exposed end bale will not spoil for 1-2 days in warmer weather and atleast a week in colder weather. Remainder of wrapped bale row should not spoil with an exposed end.

Plastic Film Disposal

Follow these instructions for proper plastic film disposal:

- Collect and dispose all plastic film in an Environmentally Friendly manner.
- Use recycling services when available.
- Do not burn plastic film.
- Do not contaminate enviroment with loose plastic film.

Section 10: Maintenance

Grease Points

Grease decals on machine signify an area to occasionally grease. Use a high quality EP grease.

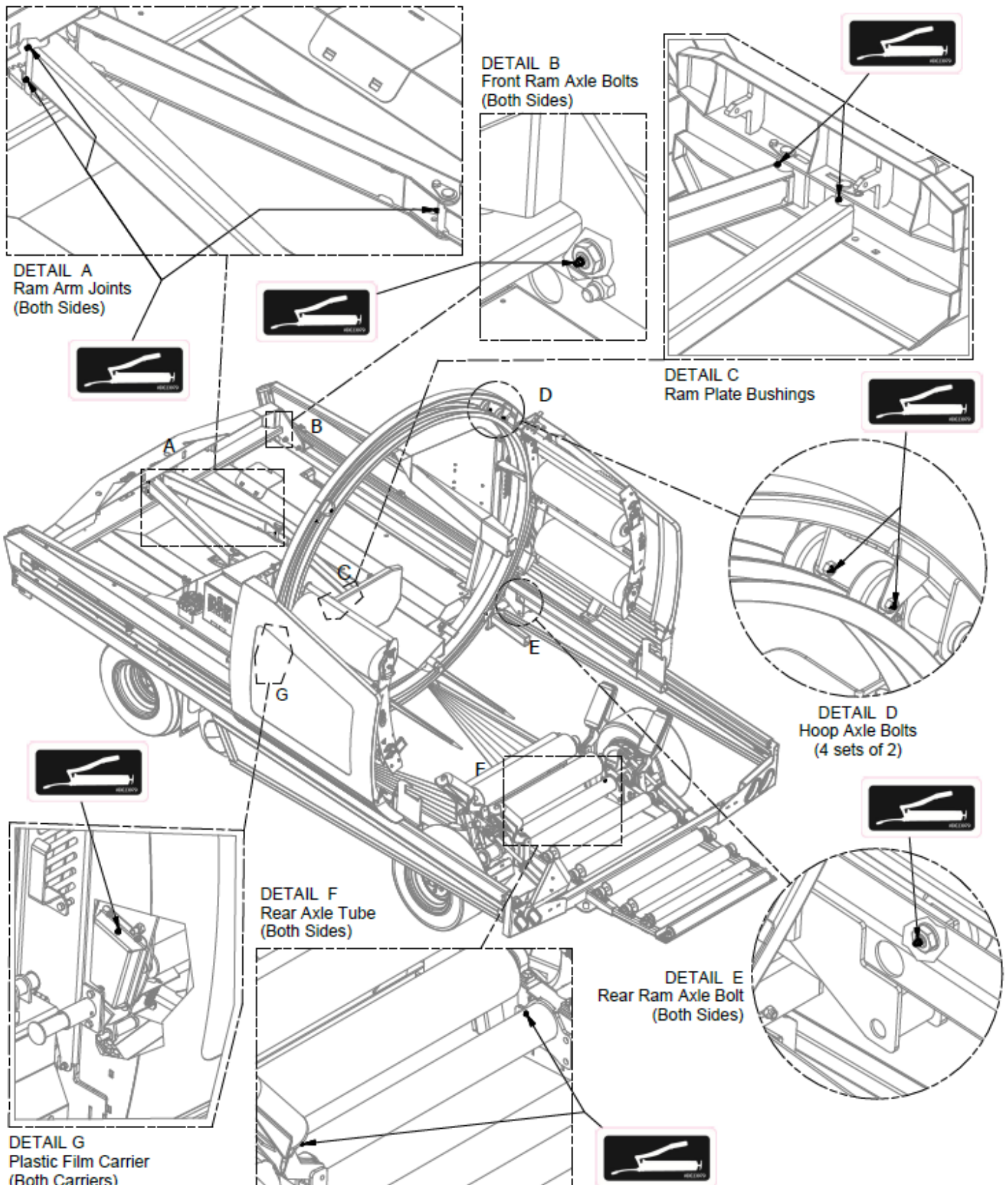

Grease Timeline

DETAIL	AREA	TIMELINE
A	Ram Arm Joints	Monthly
B	Front Ram Axle Bolts	Weekly
C	Ram Plate Bushings	Monthly
D	Hoop Axle Bolts	Twice Daily, 8 Bolts
E	Rear Ram Axle Bolts	Weekly
F	Rear Axle Tube	Monthly
G	Plastic Wrap Carriers / Gear Covers	Monthly

Hydraulic Oil

Use AW32 SAE10 hydraulic oil. Hydraulic oil tank is located in the middle of the balewrapper, under the bale deck. Check oil level gauge from right side of machine, see [Fig.1](#). Fill through cap mounted on rear of right fender, see [Fig.2](#). Do not fill oil tank more than 1/4" from top of oil fill gauge.

Follow recommended procedure in engine manual for proper engine maintenance and oil fill location.

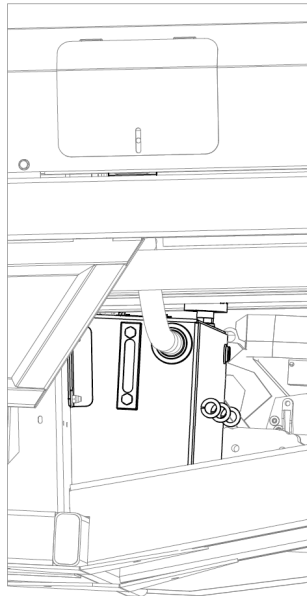

Fig.1

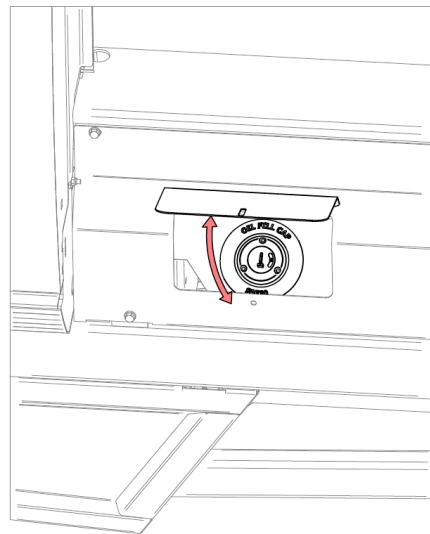
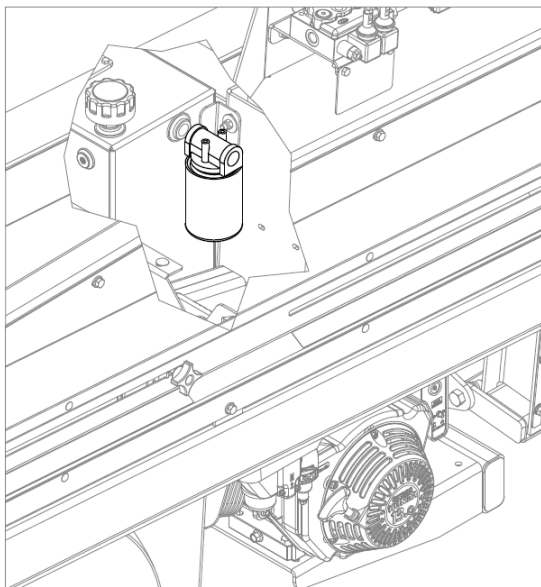

Fig.2

Hydraulic Oil Filter



Oil filter is mounted on left side of oil tank behind engine. Replace oil filter after 60 hours of operation. See chart below for recommended oil filter replacement.

FILTER CROSS REFERENCE	
FILTER	REFERENCE
Stauf	SF6520
Gresen	F22001
Fram	P1653-A
Fleetguard	HF6510
Cross	1A9021

Section 11: Diagnostics

Control Panel Relays

Electric Solenoid valves can be manually operated by pushing a small punch into the end of spool and holding it in. **Do Not Use a Hammer!**

Inside of Control Panel control relays are numbered CR1 to CR5 from left to right.

Relay CR1 is wired to table trigger. CR1 will activate solenoid valve to extend ram cylinder. CR2 is wired to switch at the front slider, when ram is extended to this switch CR2 will close, energizing the wrap motor valve. Ram cylinder will extend and wrap motor will turn until ram comes in contact with slider switch at rear, then CR1 and CR2 will turn off and CR3 will turn on. Wrap motor will stop and ram cylinder will retract until ram cylinder trips the limit switch at the front end of table. All control will then turn off.

Testing can be done by pushing trigger plate and waiting until machine goes through the wrap cycle, or you can push small square button on the front of relay 1 and let machine go through cycle.

When control relays are activated a small light goes on inside the relay.

When running machine through the cycle and wrapper motor or the cylinders do not work, check flow control valve to see if flow is going to both motor and cylinder.

Engine is stopped by grounding ignition, in case of ignition failure make sure that stop switch wire is not grounded to frame and engine is not in stop position. Steering is controlled by switch right/left on control panel through CR4 and CR5 activating coil A or B on steering solenoid valve.

With valves in neutral position, control panel on/off switch in off position, engine running fluid is pumped through manifold valve and returned to reservoir.

Wrap cycle fluid flows from power beyond port on 2 spool valve to flow control, and is split into 2 circuits one circuit goes to double solenoid valve for ram cylinder, the other circuit goes to single solenoid valve for hydraulic motor.

Electric Hydraulic Sequence of Operation

1. With valves in neutral position, control panel on/off switch in off position, engine running fluid is pumped through valve stack and returned to reservoir.
2. Wrap cycle fluid flows from power beyond port on 2 spool valve to flow control, and is split into 2 circuits one circuit goes to double solenoid valve for ram cylinder, the other circuit goes to single solenoid valve for hydraulic motor. By moving flow control handle more or less fluid will flow to cylinder or motor ie. As more fluid flows to cylinder less fluid will flow to motor and vise-versa.
3. Electric control panel- **MAN-AUTO** switch turned to **MAN**. Turn **ON-OFF** switch to **ON**, then red LED will light up indicating 12V power is on at control circuits, with engine running. Turn **FORWARD** switch in to energize solenoid A on double solenoid valve. Ram cylinder will extend. Turn **REVERSE** switch to energize solenoid B on same valve. Ram cylinder will retract. Push **ROTATE** button in and hydraulic motor will run. **FOR-REV** and **PUSH** buttons have to be held to operate, by releasing them action will stop. Engine throttle has linkage to slow engine down when ram is all the way to the front. Spring on linkage will speed engine up as soon as Ram cylinder starts to extend.

4. When **MAN-AUTO** switch is turned to **AUTO**, **FOR-REV** and **ROTATE** switches no longer function. Depress trigger switch located on bale table, Ram hydraulic valve is energized. The Ram cylinder will extend and engine will speed up. When Ram extends to front slider, this switch will energize the single solenoid valve and turning the wrap motor. When Ram is extended to the limit switch at the end of stroke, single solenoid valve and double solenoid valve "A" will turn off. Solenoid B will energize causing Ram cylinder to retract until it trips limit switch at the front end of bale table, solenoid "B" will turn off, the Ram cylinder will stop and engine will idle down.
5. Steering is done by steering switch, right/left activating steering double solenoid valve A or B. This valve will work in either manual or automatic mode.

Manifold Port Connections

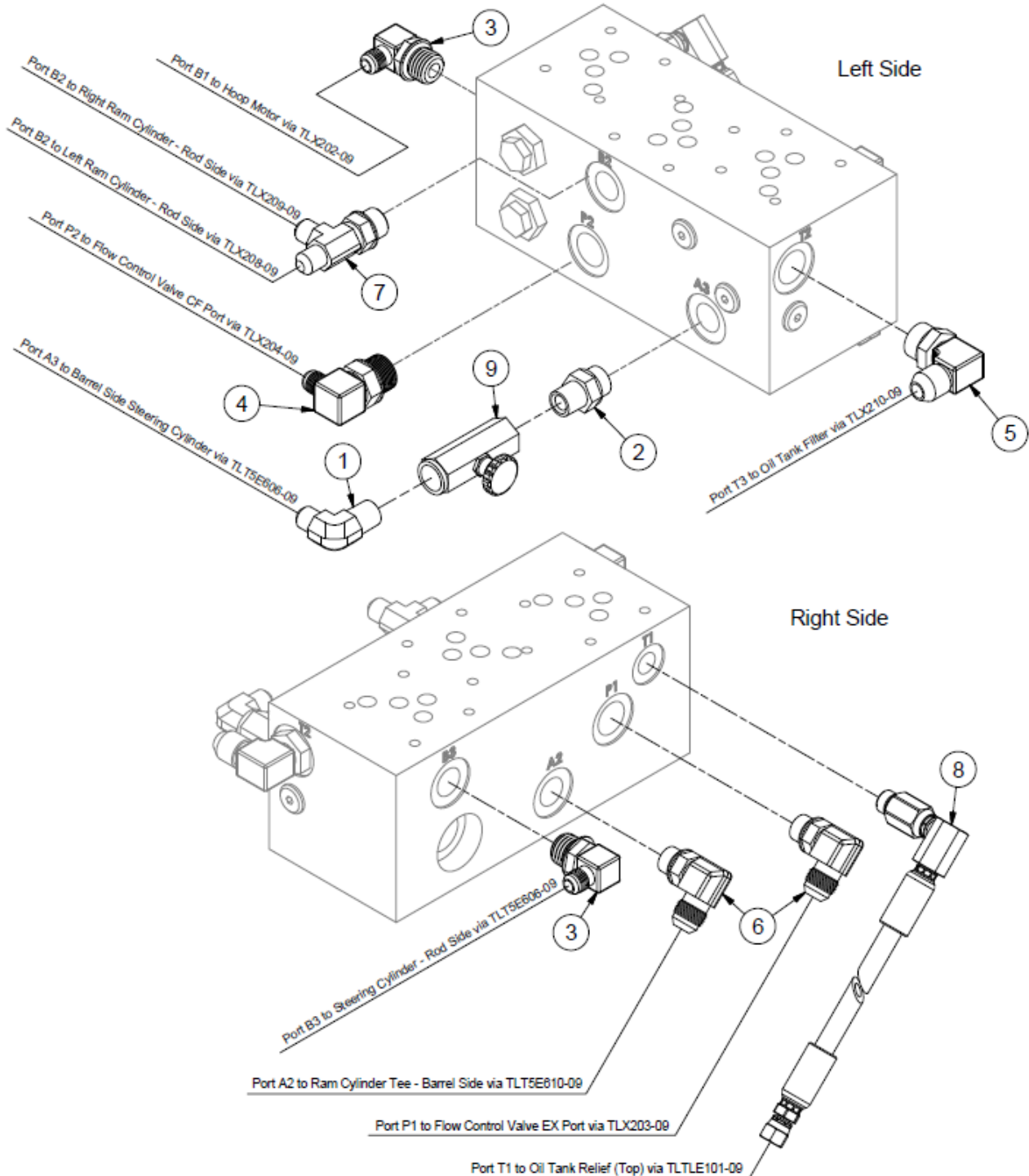

Troubleshoot Plastic Film and Carriers

1. Plastic film rips while wrapping:

- Hot weather causing adhesive tack buildup on rollers. Remove the adhesive with soap and water.
- Spray plastic wrap carrier rollers **(A)** with WD40.
- Store plastic rolls in a cool dry place before use.

OR

- Poor quality plastic, use a brand with good tear resistance.

2. Wrinkles in wrapped plastic with seams between layers visible:

- Check to determine if the plastic is properly routed through the carrier rollers. Install the plastic film rolls according to the Plastic Installation diagram, refer to [pg.4-4](#).

3. Plastic film carrier rollers not turning freely:

- Bearings have too much end pressure. Loosen the bolts holding the bearing.

OR

- Roller gears **(B)** meshed too tight. Slightly loosen one set of bearing bolts. Using a hammer and punch, lightly tap the bearing away from the other roller.



CAUTION: Do not use a hammer on the aluminum stretcher rolls.

4. Plastic film sticks to bale spears and tears the plastic inside the bale.

- Ensure bale sit firmly on the bale deck, bale spears should deflect the hay somewhat.

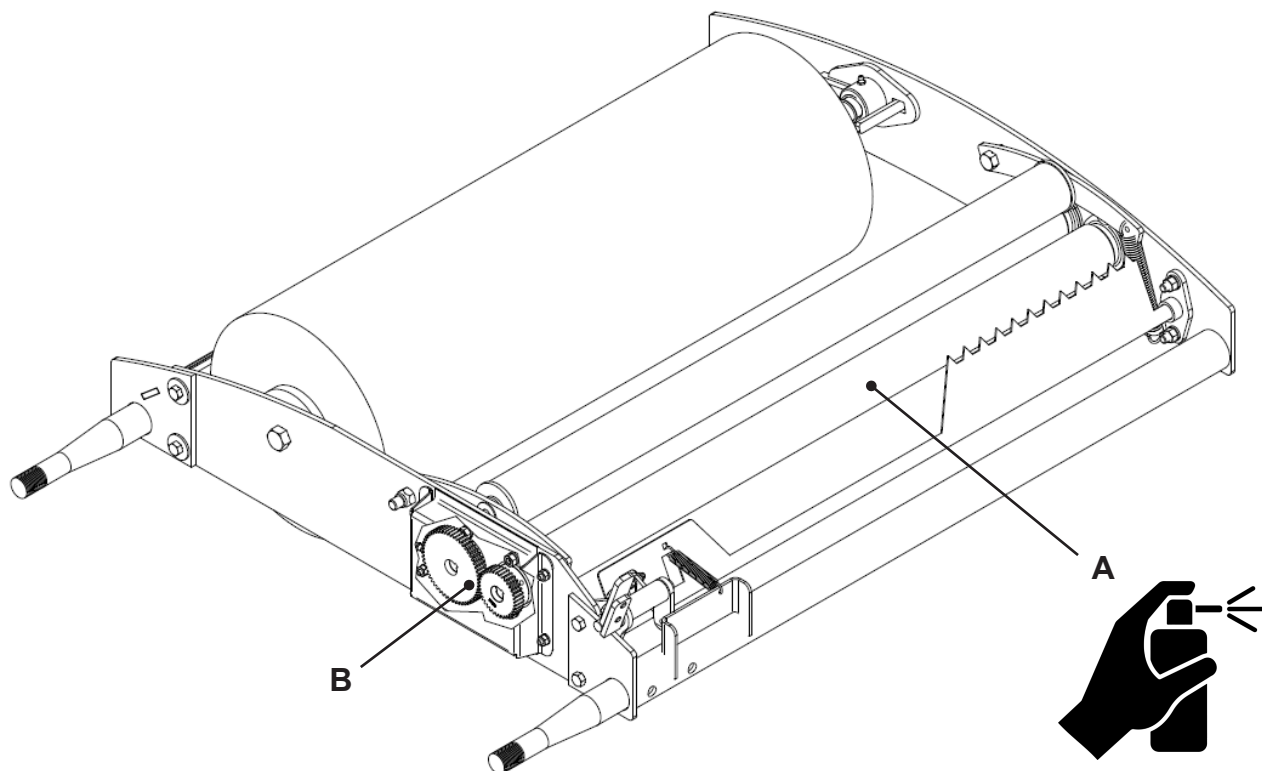

Section 12: Option - Power Drive

Refer to [Parts Manual](#) to confirm that you have all the parts necessary for this option.

Ensure bale wrapper is turned off and suitably parked before installing this option.

NOTE: Fully tighten all hose and hydraulic fittings after installation before attempting to operate. If needed, top up hydraulic oil tank.

Apply Power Drive decal (A) under hydraulic spool valve, to left of existing roller bed decal.

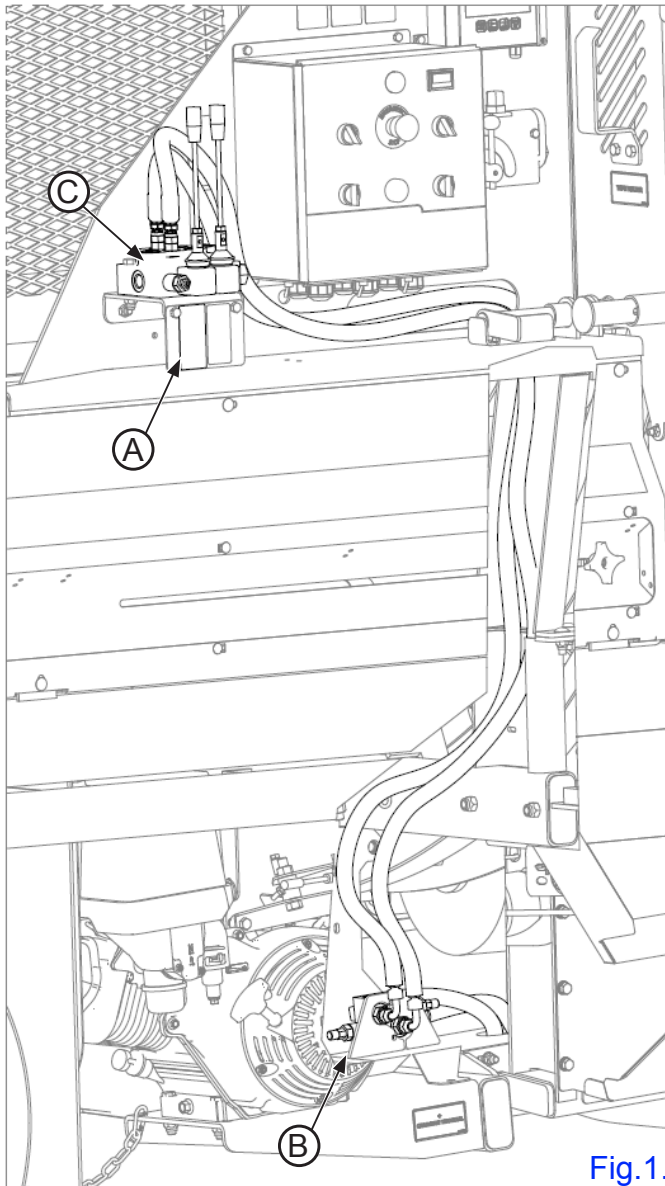

Fig.1.

Power Drive Installation - Hydraulic Control Circuit

1. Mount crossover relief valve (B) with supplied bolts and nuts to plate in front of the hoop drive wheel.
2. Insert two HF6400-6-8 fittings in outside facing crossover relief valve ports and two HF6801-6-8 fittings to inner facing ports.
3. Remove caps from top left ports (towards front of machine) of hydraulic spool valve (C).
4. Insert two HF6400-6-6 hydraulic fittings into hydraulic spool valve ports.
5. Route the two hoses marked "41512" from the hydraulic control valve to outer face of crossover relief valve. Make sure the ends with 90° fittings are towards the crossover relief.
6. Connect hose ends to hydraulic fittings:
 - Front left hydraulic spool valve fitting to bottom crossover relief valve fitting.
 - Rear left hydraulic spool valve fitting to top crossover relief valve fitting.

Power Drive Installation - Single

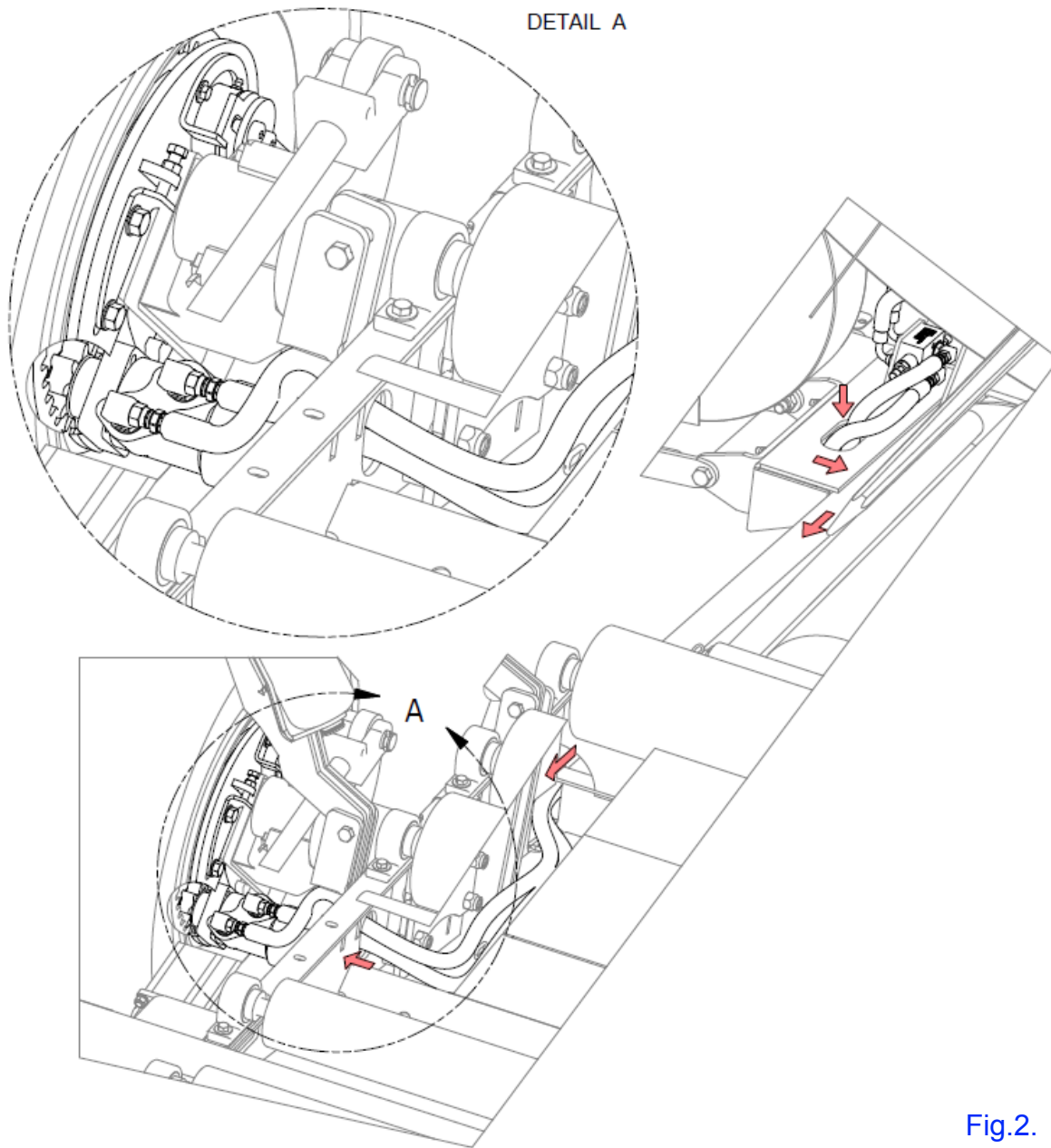

Fig.2.

1. Chock rear tires and disengage parking brake if it is set.
2. Remove existing brake pad from parking brake bracket. Reuse bolts to fasten supplied hydraulic motor as shown in Fig.2.
3. Ensure power drive gear sprocket meshes with the rim gear by engaging/ disengaging parking brake handle.
4. Route two hoses marked "26919" from crossover relief valve through hoop wheel mount and side frame tube to middle of roller bed, then through the left roller bed mount plate to the hydraulic motor. Make sure 90° hose ends are towards crossover relief valve. See arrows in Fig.2.
5. Connect hoses as follows:
 - Bottom crossover relief valve fitting to hydraulic motor fitting closest to wheel.
 - Top crossover relief valve fitting to hydraulic motor fitting furthest from wheel.

Power Drive Installation - Dual

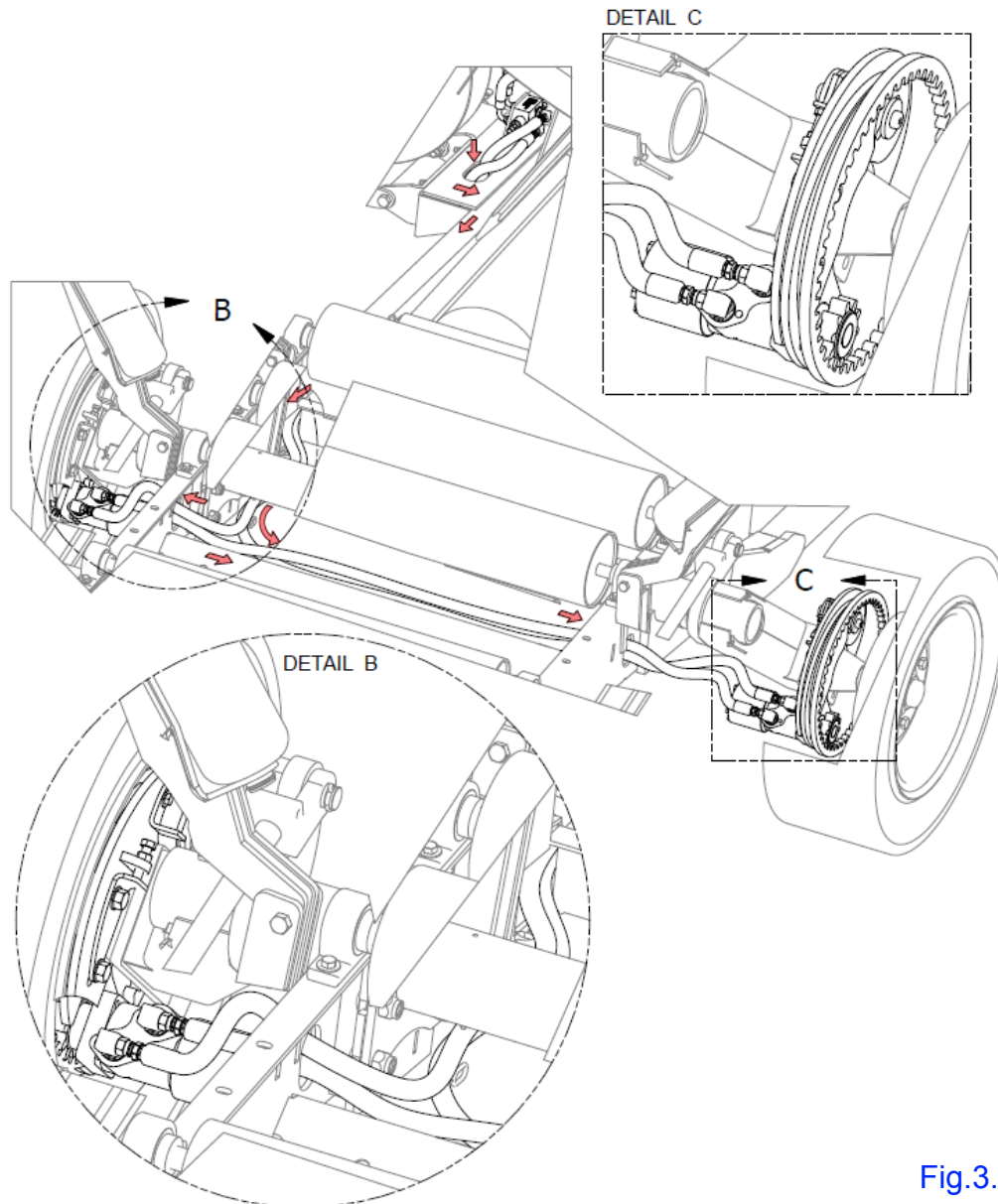
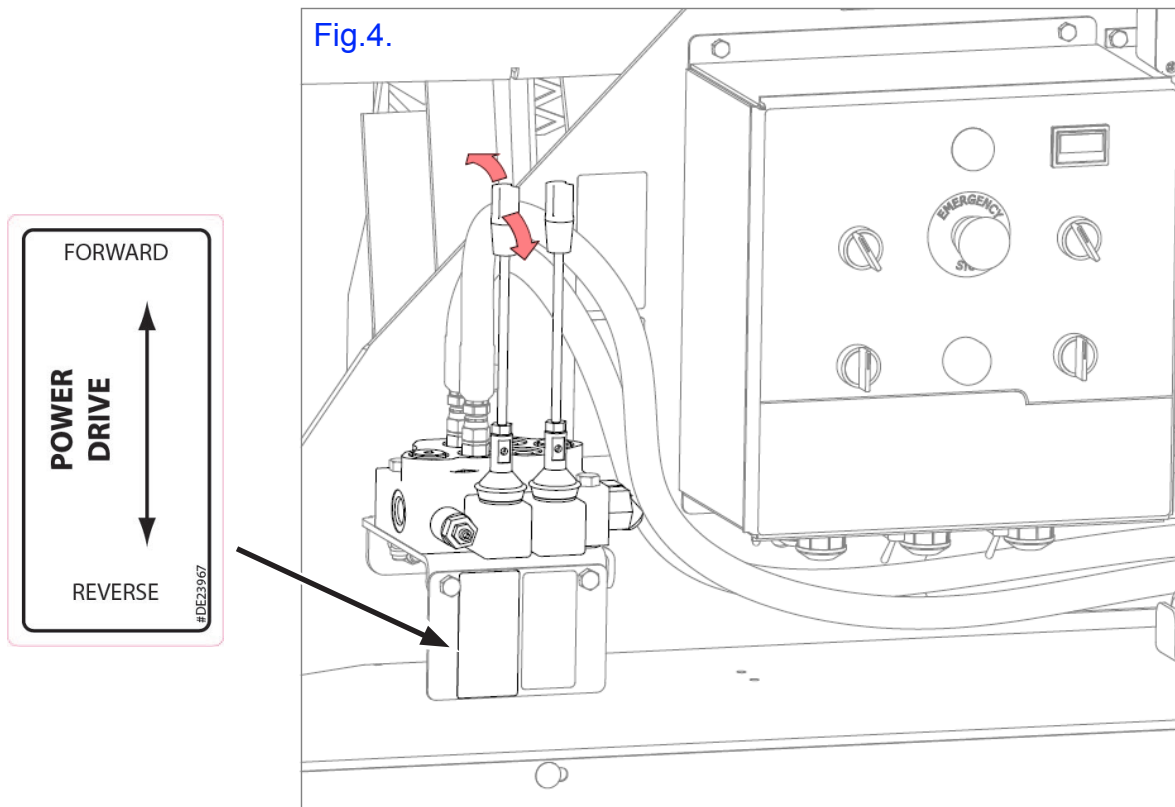

Fig.3.

1. Chock rear tires and disengage parking brake if it is set.
2. Remove existing brake pad from parking brake bracket. Reuse bolts to fasten supplied hydraulic motor as shown in Fig.3.
3. Bolt right side power drive bucket to right side of rear axle with supplied bolts and nuts. See [Parts Manual](#) for full assembly breakdown. **NOTE:** Right rear tire may need to be removed.
4. Ensure power drive gear sprockets mesh with rim gears by engaging/ disengaging handles.
5. Route hoses from crossover relief valve through hoop wheel mount and side frame tube to middle of roller bed, then through the left roller bed mount plate to the hydraulic motor. Make sure 90° hose ends are towards crossover relief valve. See arrows in Fig.3.
6. Connect hoses as follows:
 - Hose “26919” - Bottom crossover relief valve fitting to left hydraulic motor fitting closest to wheel.
 - Hose “44904” - Top crossover relief valve fitting to right hydraulic motor fitting closest to wheel.
 - Hose “44903” - Via shortest distance between left and right hydraulic motors.

Power Drive Operation



Push left handle of hydraulic spool valve inwards to drive machine forward and pull handle down to reverse machine as desired.

Releasing handle will return it to neutral position and stop the bale wrapper from travelling further.

Section 13: Option - Remote Control

Remote Control Installation

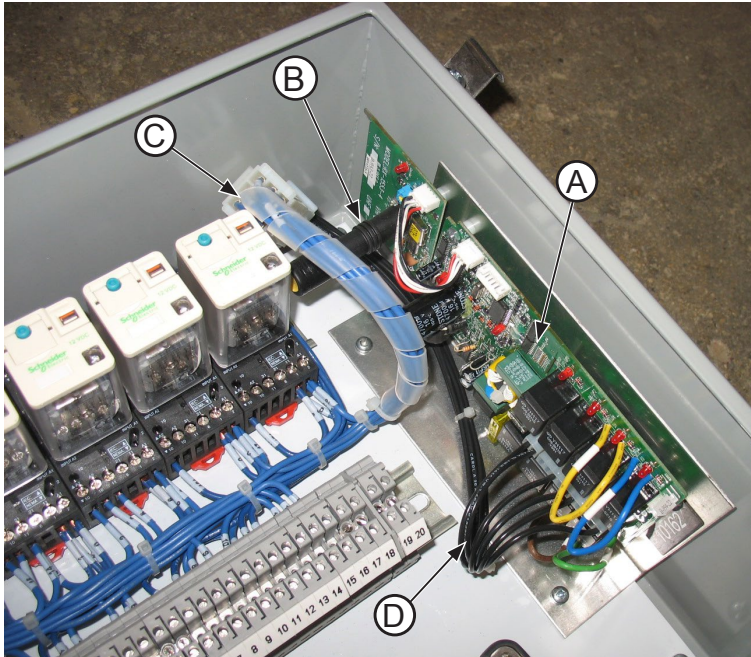

- Bolt receiver circuit board assembly (A) to inside rear right of control box with antenna (B) towards top.
- Locate the 6 wire pigtail (C) inside the control panel.
- Remove the jumper plug from control panel pigtail (D) and connect the remote control board pigtail.

NOTE: All remote control units use the same frequency, no programming is required.

NOTE: Remote requires 2 AA batteries. Avoid rechargeable batteries, as the chemicals in these interfere with remote signals.

Remote Control Function

ON/OFF – Turns handheld unit on/off (detent has no function).

START – Starts the wrap cycle (unplug the table switch if you prefer to start each cycle with this button), this will not restart the hoop if cycle is broken after Hoop Start was triggered.

STOP – Stops the wrap cycle (if the table switch is not unplugged and it has a bale holding it down, it is necessary to hold stop until the circuit is broken by switching to manual mode at the control panel).

LEFT - Steers left.

RIGHT - Steers right.

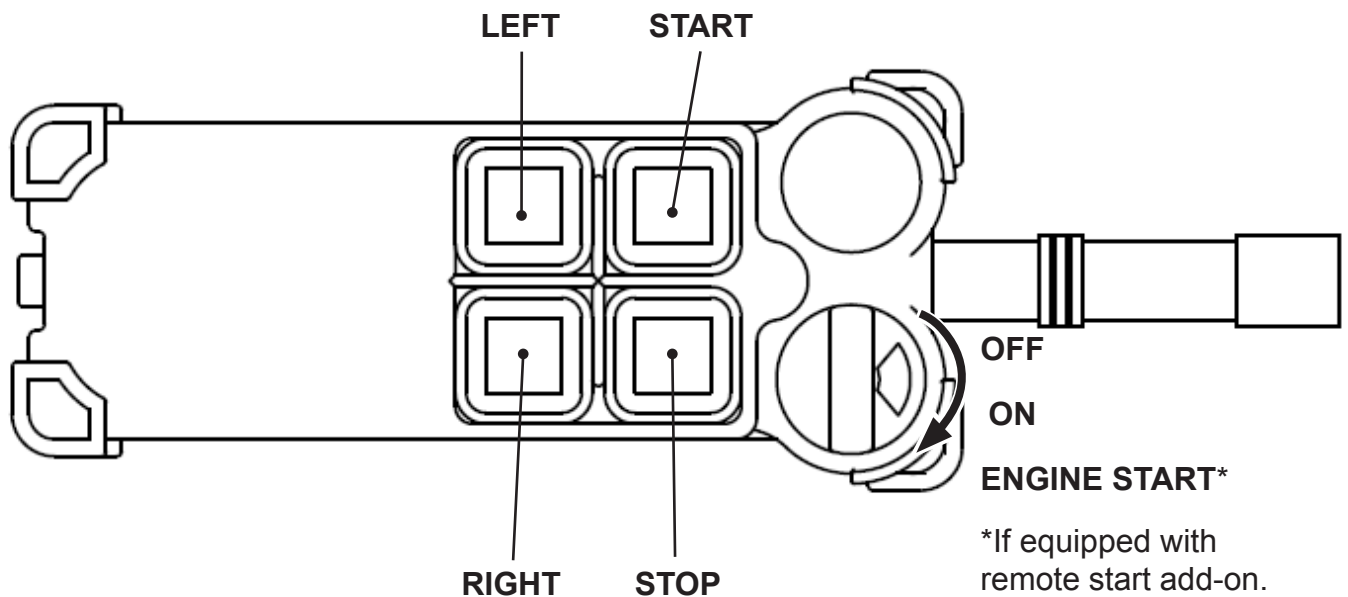

Option - Remote Control Start Add-on*

* To order this option you must have a remote control [see previous page(s)]

Remote Start Add-on Installation

Read the following instructions before attempting to install.

Make sure you have both remote switch **(A)** and power wire **(B)**.

1. After making sure your wrapper's engine and control panel are switched off, open your control panel and unplug the 2 white pin plugs.
2. Connect the provided power wire **(B)** into the top number 7 port on the control panel terminal strip. Splice this new wire into the existing number 7 wire to install.
3. The silver capped end on the provided wire **MUST** be threaded into this plug **AND** this port. (Fins on the cap will hold the wire in place once inserted).
4. Plug 2 white existing plugs into the 2 white plugs on the provided remote start switch **(A)**.

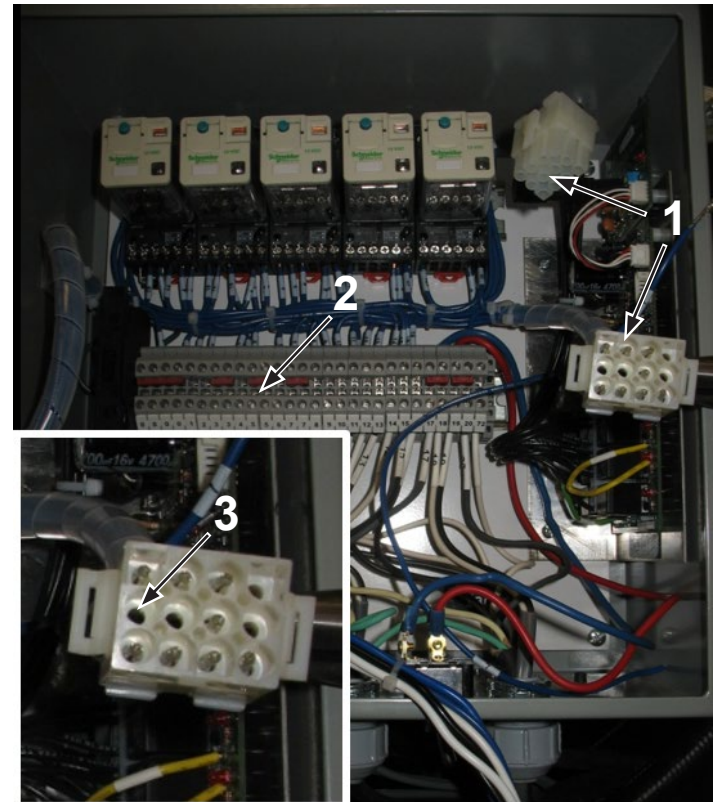
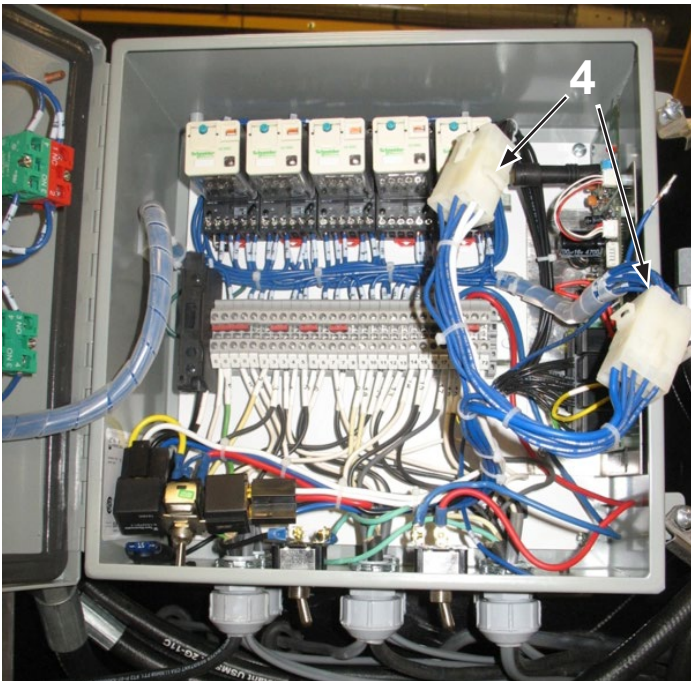
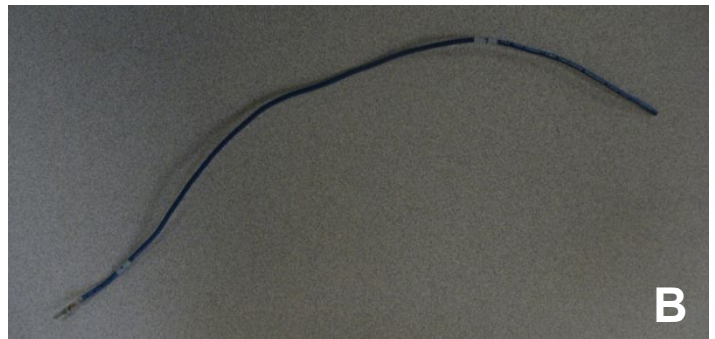

5. Unscrew one of the hex jam nuts from the bottom of the switch on the remote start.
6. Drill 1/2" hole into bottom of control panel if your machine is older than serial # 13R058. If newer, remove black plug.
7. Slide the switch through the hole in the bottom of the control panel and refasten the hex jam nut you took off in step 6.
8. Close the control panel.
9. Apply provided decal to bottom of control panel, over installed switch.

Remote Start Add-on Operation

Your new remote start is now complete.

To use this feature follow these steps:

1. Flip switch on bottom of control panel to Remote Engine Start.
2. Twist the green dial on your orange remote past the ON position. (You may have to hold it open for a moment, especially if cold starting).
3. If the machine doesn't start you may want to engage the throttle slightly.

For troubleshooting please contact your local dealer or contact us using the information provided on [pg.11](#) of this manual.

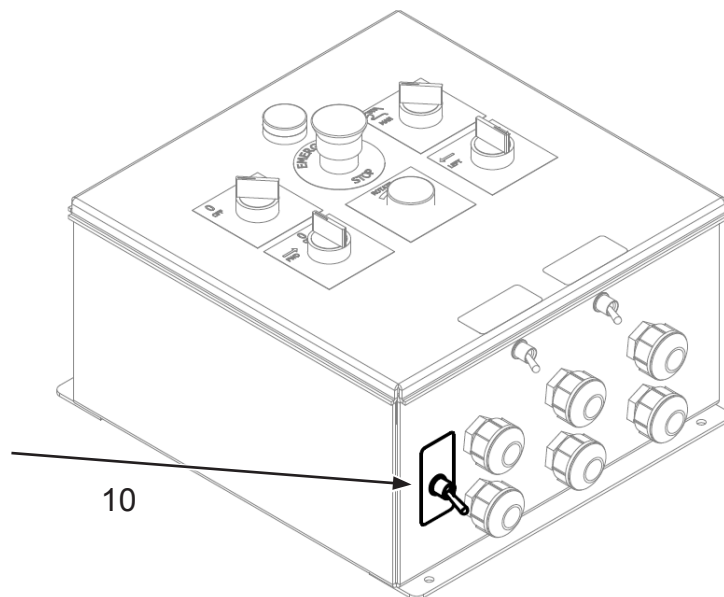
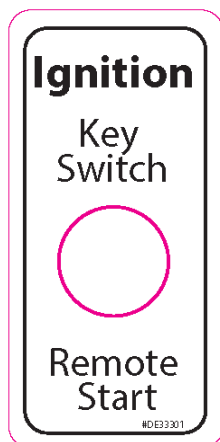
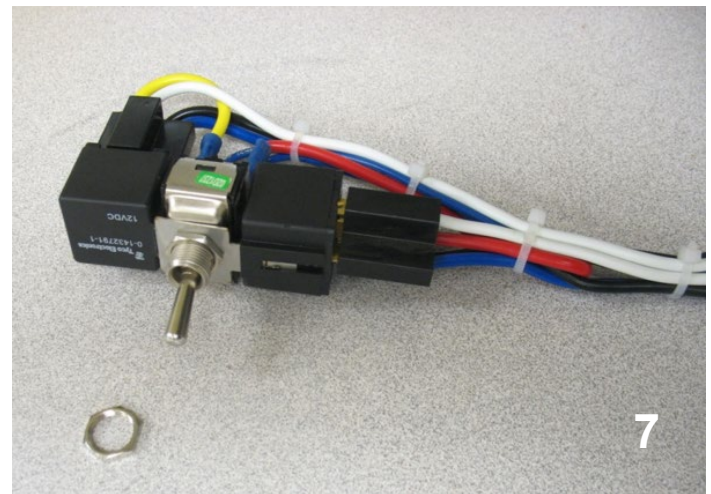
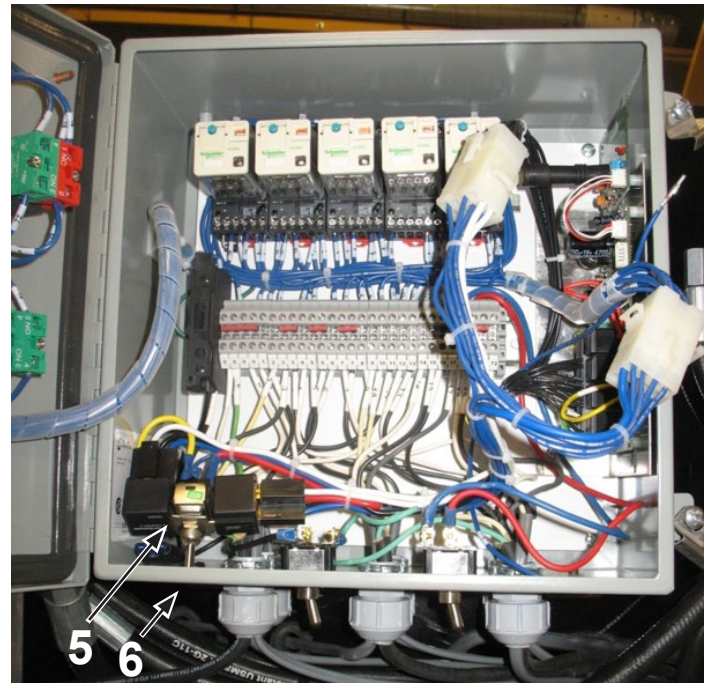

Section 14: Option - Plastic Film Sensor

Film Sensor Installation

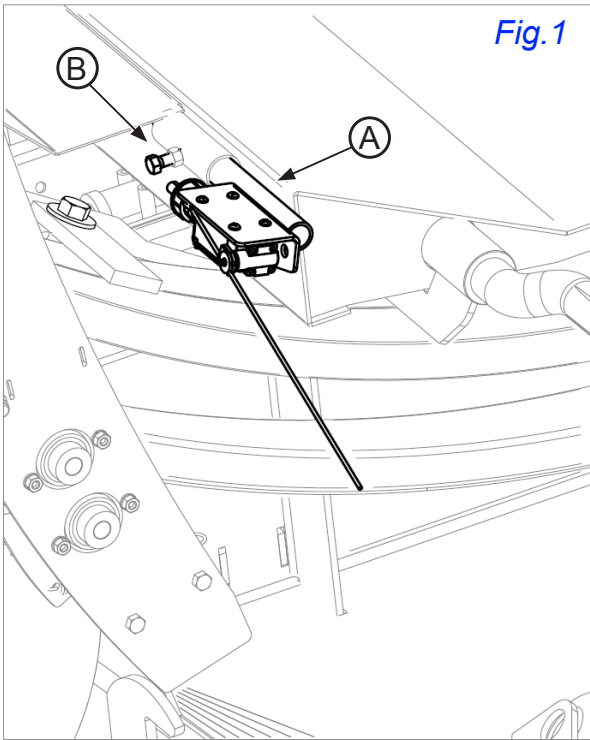

Ensure all parts have been received. Refer to [Parts Manual](#).

1. Install film sensor bracket **(A)** by sliding into frame tube and locking with provided bolt **(B)**. See [Fig. 1](#).
2. Locate the “Film Sensor” wire attached to frame.
3. Remove plug from frame film sensor wire.
4. Connect frame film sensor wire plug and film sensor switch harness.
5. Install provided toggle switch in the control panel. Blue wire should be towards left side of control panel. See [Fig. 2](#).
6. Remove the jumper wire between control panel terminal 18 and 19. See [Fig. 3](#).
7. Connect toggle switch blue wire to control panel terminal 18.
8. Connect toggle switch red wire to control panel terminal 19.

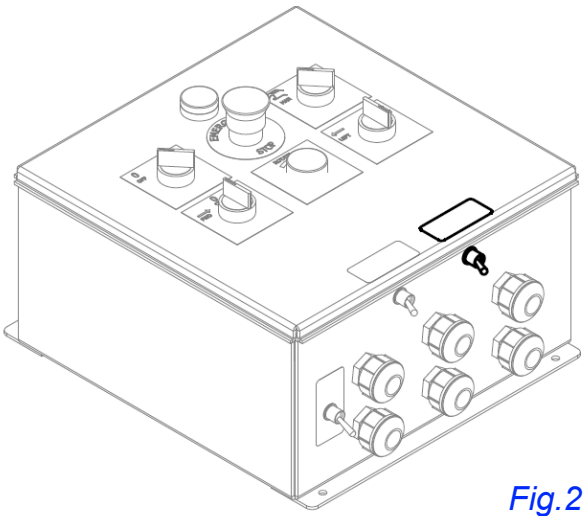
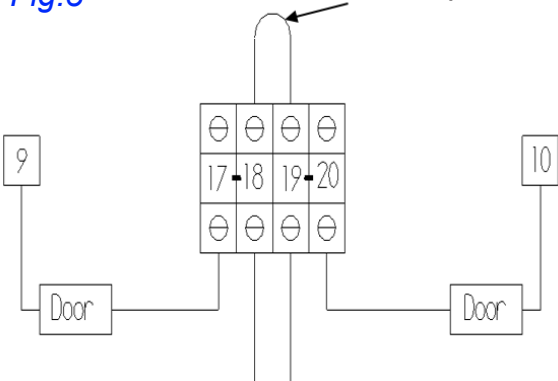

Fig. 3

Remove Jumper Wire



Plastic Film Sensor Adjustment

Sensor wire must be adjusted so that only one layer of plastic is covering the end of the wire while wrapping. Adjustment can be made on the bracket and on the sensor wire. The end of the sensor wire behind the switch can be bent to allow the wire in front of the switch to drop down far enough to trip the switch when no plastic is present.

NOTE: Use measurements as initial guide only.

- Measure length of wire from the hoop face (see previous page)
- 9.5" wire = approx. 3" between wraps = 8-9 layers per bale
- 9.5" wire should stop hoop rotation just after an empty tensioner passes the wire
- Lengthen wire 3" for 4 layers of wrap or 1.5" for 6 layers
- Shorten wire by 1.5" for 10 layers per bale

NOTE: As a guide, if the hoop stops before an empty plastic film carrier passes the film sensor wire, the wire is too short and if the hoop does not stop with one empty plastic film carrier the film sensor wire is too long.

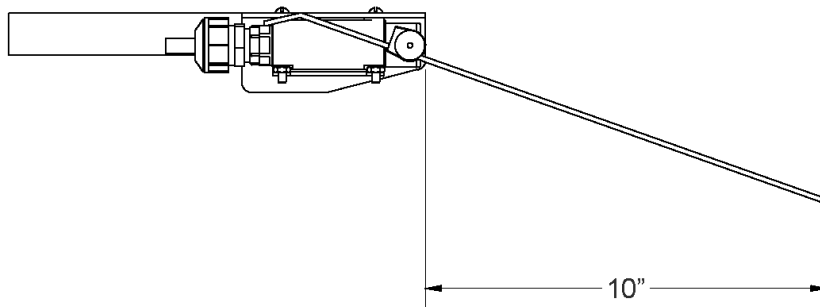

Plastic Film Sensor Operation

- Flip Film Sensor toggle switch to "Enable" on control panel. See [pg.3-2](#).
- Make sure plastic film sensor wire is on top of plastic film after installing new plastic rolls.
- Plastic film sensor wire drops when plastic film roll empties or breaks, causing wrap cycle to stop.

Section 15: Option - Wireless Plastic Film Sensor

Wireless Film Sensor Receiver Board Installation

Fig.1

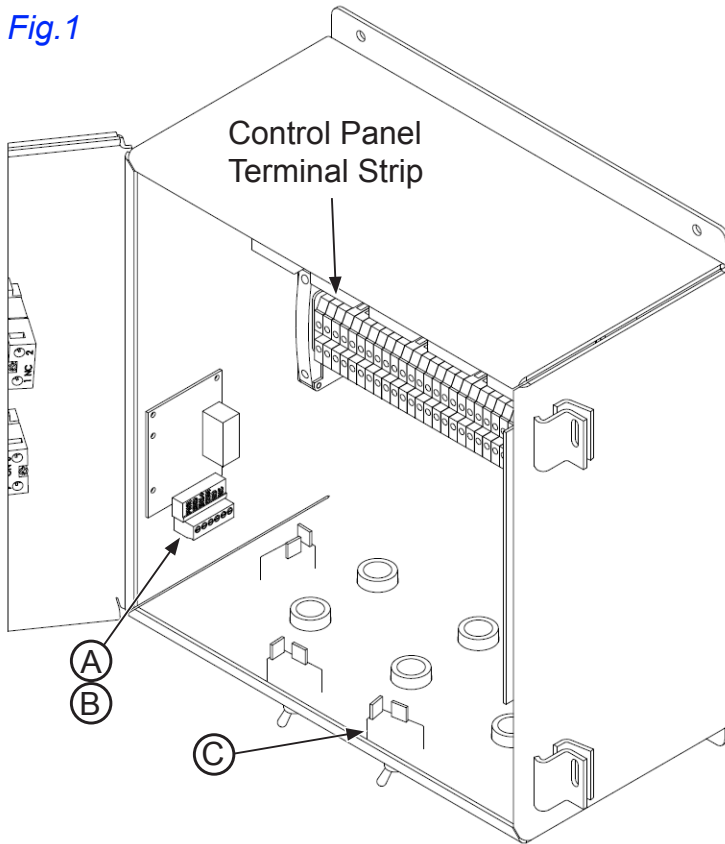

Ensure all parts have been received. Refer to [Parts Manual](#).

1. Install film sensor receiver board (A) to inside left edge of control panel using velcro strips. Receiver's green terminal block (B) should be on the bottom. See Fig.1.
2. Install toggle switch (C) if your machine does not already have one. See Fig.1.
3. Remove existing white wire (D) from control panel terminal "10". Connect to toggle switch rear terminal. (Rear toggle switch terminal jumps to COM terminal on receiver board, wire marked "SW".) See Fig.2.
4. Connect receiver board terminal NC to control panel terminal 10 via toggle switch's left terminal.)
5. Connect loose GND black wire from receiver board to any control panel "0" terminal.
6. Connect loose black IN 1+ wire from receiver board to control panel terminal "1".
7. Connect loose black PWR wire from receiver board to control panel terminal "7".

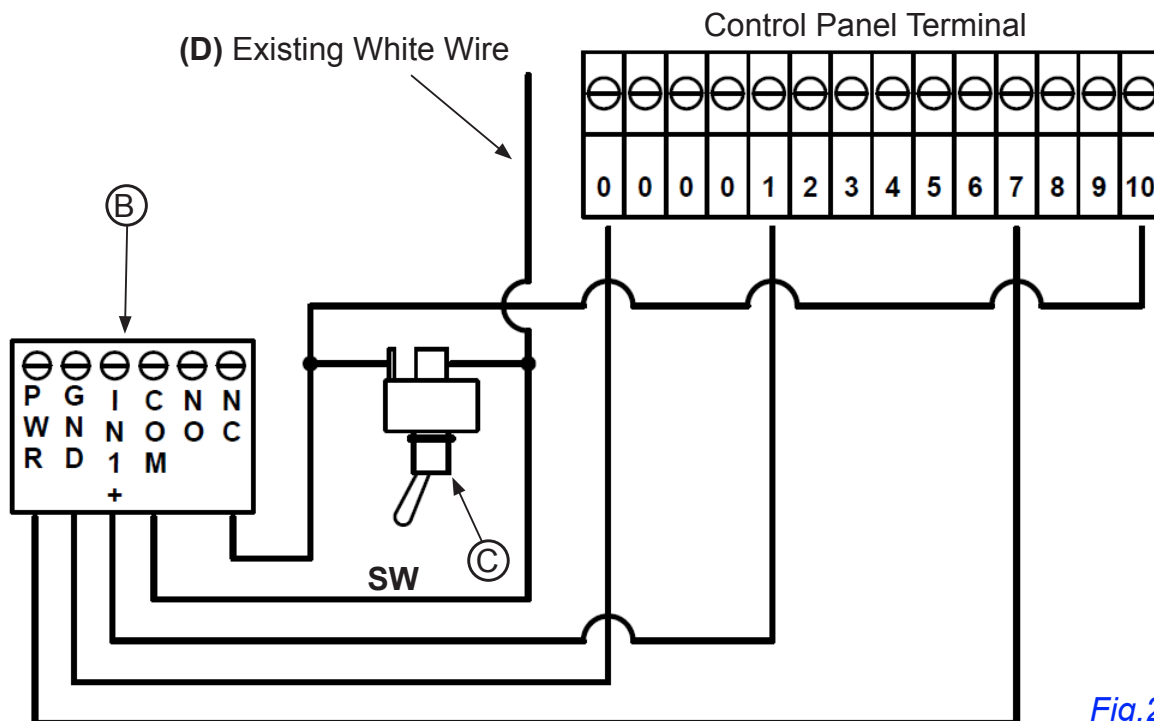

Fig.2

Wireless Film Sensor Transmitter Installation

Ensure all parts have been received. Refer to [Parts Manual](#).

1. Ensure two (2) 1.5V AAA alkaline batteries are inserted into each transmitter (A). See [Fig.1](#).

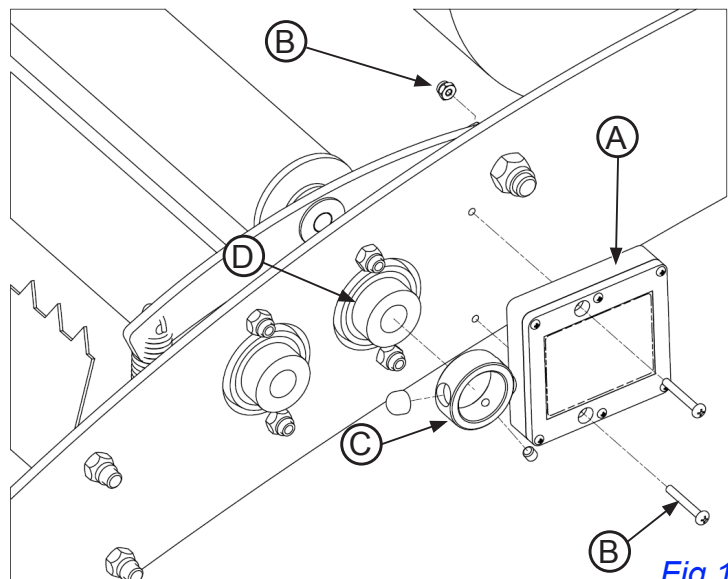

Fig.1

NOTE: When replacing batteries, **DO NOT** use rechargeable batteries. These can interfere with transmitter broadcasting.

2. Push magnet bushing (C) over closest roller bearing collar (D), backing off slightly to avoid wearing on wrap carrier. Ensure the magnet bushing is installed with set screws towards inside edge for full contact with roller bearing collar when tightened.
3. Drill holes through plastic wrap carrier frame so that when transmitter is mounted, it is 1/16" from tip of rare earth magnet. See [Fig.2](#).
4. Install transmitters on each plastic wrap carrier frame with provided machine screws and lock nuts (B). Transmitter end marked "MAGNET" positioned towards wrap carrier rollers. See decal image to left.

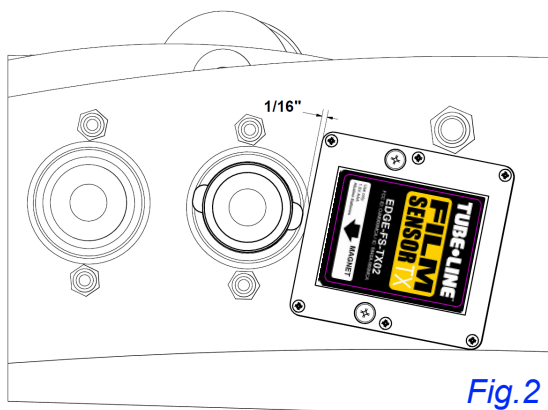

Fig.2

Wireless Film Sensor Test

- Flip Film Sensor toggle switch to "Enable" on control panel. See [pg.3-2](#).
- To test Film Sensor turn on control panel and open lid.



DANGER: Do **NOT** attempt with engine running!

- Activate first two relays (E) by pressing small green buttons, do not lift locking tabs.
- Hand turn plastic wrap carrier aluminum rollers briefly to simulate normal wrap operation. When rollers stop turning the two relays should deactivate.

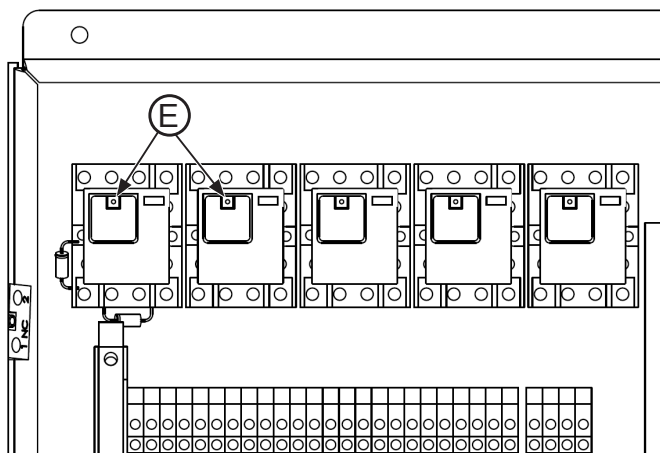

Fig.3

Wireless Film Sensor Operation

- Film sensor transmitter reads magnet bushing rotation as normal film dispencing.
- When a plastic roll empties or film breaks, magnet bushing stops rotating as no film is passing over its parent roller. The transmitter no longer senses magnet bushing rotation, signals the control panel reciever board which in turn signals the hoop controlling solenoid to cut off hydraulic flow to the hoop. This causes the wrap cycle to stop, ensuring no bales are pushed through the wrap chamber without plastic film coverage.

Section 16: Option - Dispatch Arm

Dispatch Arm Installation

Refer to [Parts Manual](#) to ensure all parts have been received.

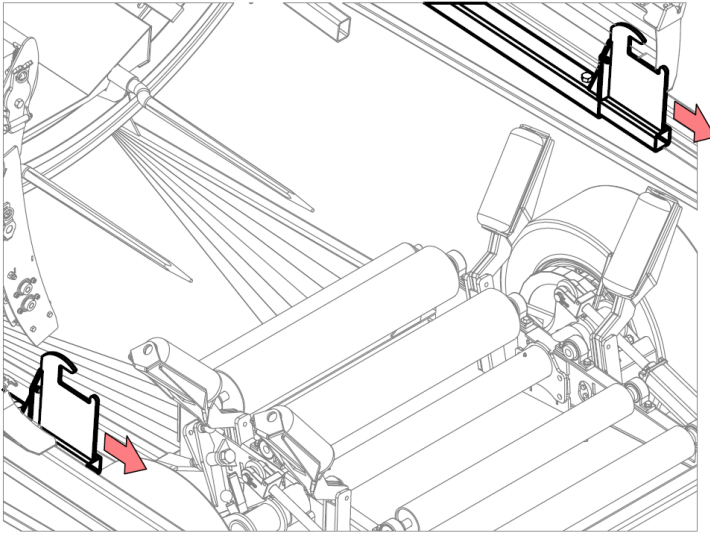

Fig.1

1. Remove standard last bale pushoff hooks from ram tubes. Keep unfastened hardware. See [Fig.1](#).
2. Insert right dispatch arm pocket into right ram tube. Lock with existing bolt and nut. See [Fig.2](#).
3. Use a lifting device to raise dispatch arm assembly.
4. Slide dispatch arm into left ram tube. Bolt with existing bolt and nut.
5. Lower dispatch arm to ensure it fits into right side pocket. See [Fig.3](#).

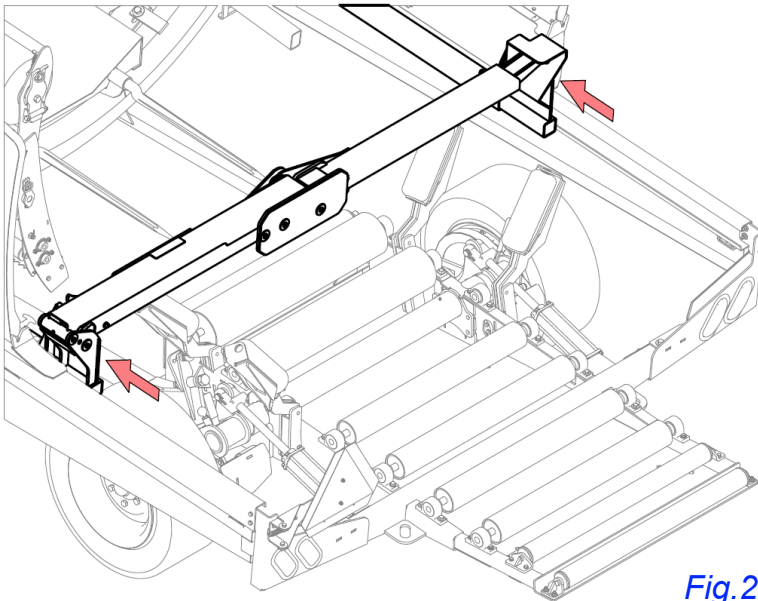

Fig.2

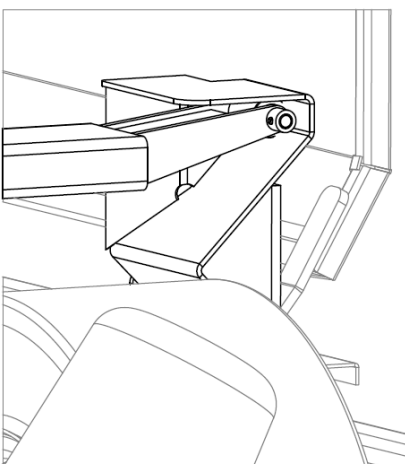
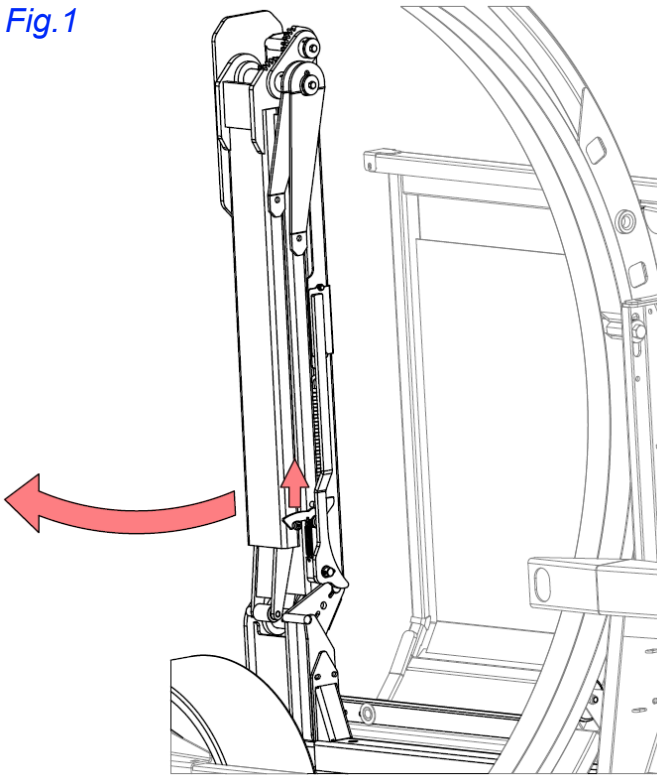

Fig.3

Dispatch Arm Operation

Fig.1



1. Unhook latch from lower inside edge of dispatch arm. See Fig.1.
2. Use handle to unfold and lower the dispatch arm across the roller bed and into right side pocket.
3. Finish bale row as instructed in [Ending Bale Row](#) on [pg.7-3](#).
4. Raise dispatch arm to folded position with handle and lock latch if starting a new row. See Fig.2.



WARNING: Keep dispatch arm in lowered position for highway transportation.

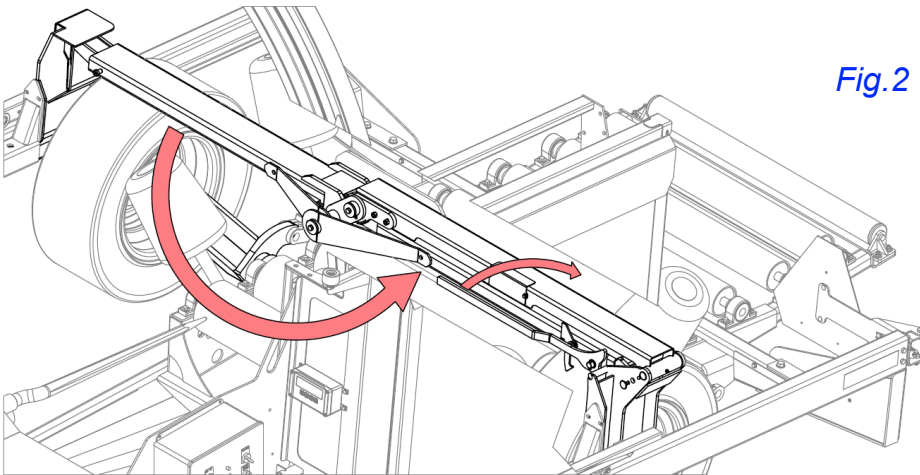

Fig.2

Section 17: Option - Guide Roller Kit

This option allows for better bale row alignment and may be necessary in uneven wrapping situations.

Guide Roller Kit Installation

Refer to [Parts Manual](#) to ensure all parts are included.

1. Slide left and right guide rollers into their respective holders.
2. Bolt in place with provided hardware.

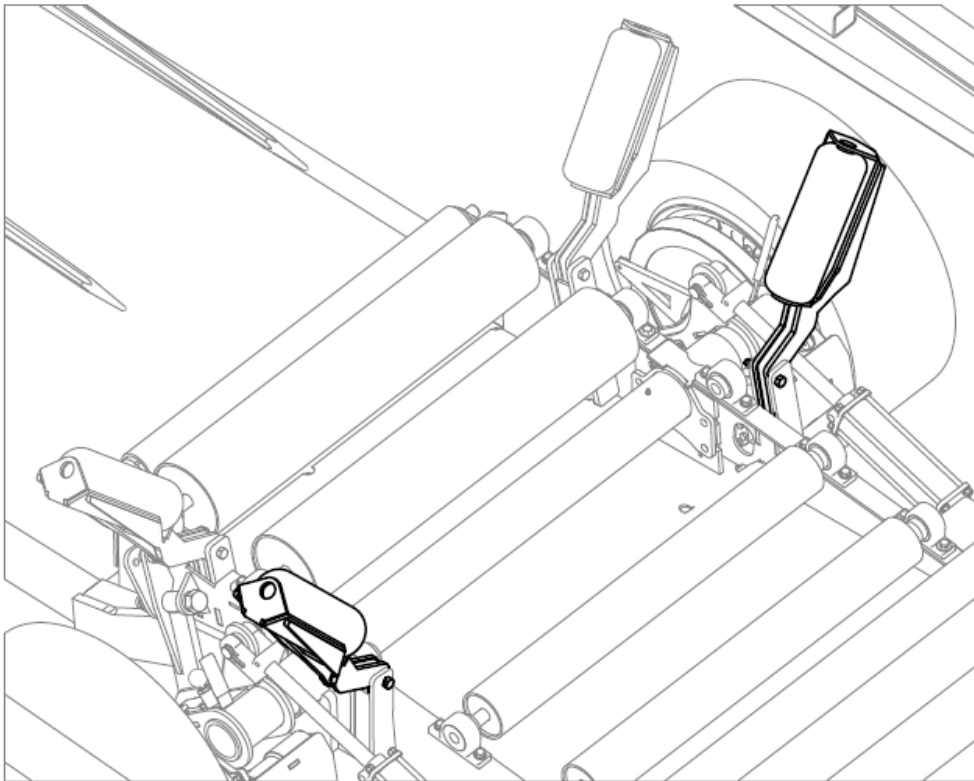

Section 18: Option - Night Light Kit

NOTE: Left and right light brackets are shipped pre-assembled. Both halogen and LED kits install the same way, only difference is the actual lights. Left side has three lights, right side has one.

Night Light Kit Installation

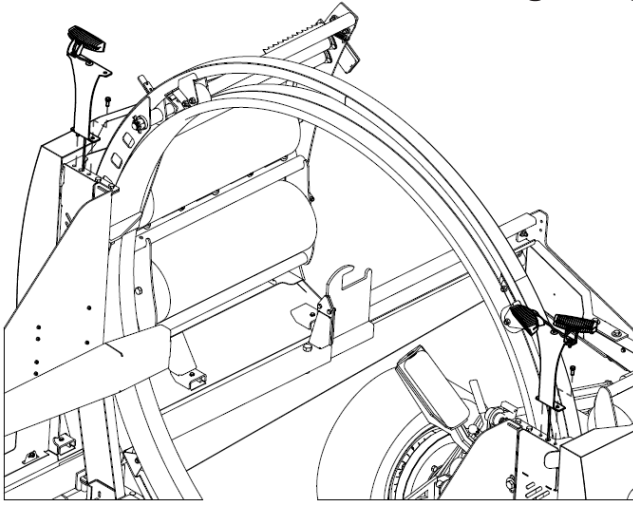

Fig.1

Refer to [Parts Manual](#) to ensure all parts are included.

1. Install left side on top of left safety guard mount with provided hardware. See [Fig.1](#).
2. Install right on top of right safety guard mount with provided hardware.
3. Route night light kit wiring harness through large hole in top of safety guard mount.



WARNING: Ensure all machine power is switched off before installing electrical components.

4. Connect left and right night light wiring harness plugs to main frame harness plugs that are tied to safety guard mounts.
5. Install toggle switch **(A)** with side prong towards right side of control panel. See [Fig.2](#).
6. Locate green “Night Light” wire **(B)** in control panel. Connect to right side prong on toggle switch.
7. Connect toggle switch black fuse wire **(C)** to control panel fuse holder.

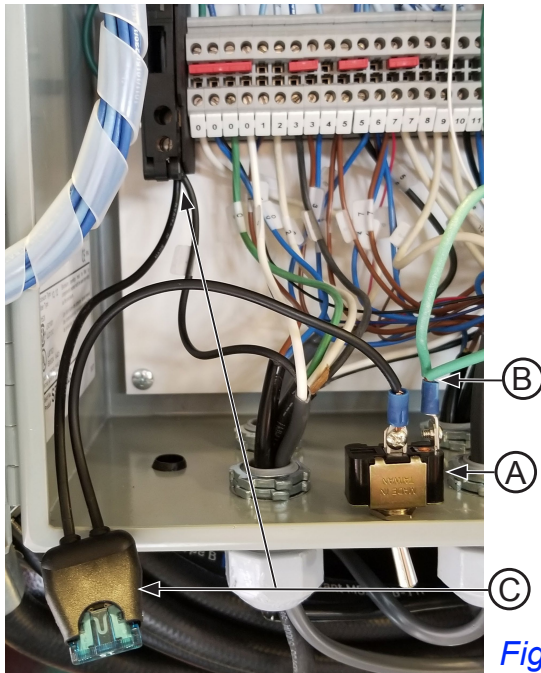

Fig.2

Night Light Kit Operation

1. Flip toggle switch on control panel to illuminate bale deck and wrap chamber.
2. Flip toggle switch again to turn off lights.

Section 19: Option - Twin Wrap Kit

Twin Wrap Kit Installation

Refer to [Parts Manual](#) to ensure all parts have been received.

1. Rotate hoop to a position where the twin wrap kit can be easily placed in position.



DANGER: Shutoff machine before installation.

2. Open left safety guard.
3. Place twin wrap kit on top of standard plastic film carrier.
4. Bolt in place with provided hardware. Handles must be placed through top side and fully tightened.
5. The 3 socket head bolts must be placed through bottom side. Do not fully tighten to allow tensioner to slide. See [Fig.1](#).
6. Repeat steps 1-5 for other plastic wrap carrier.

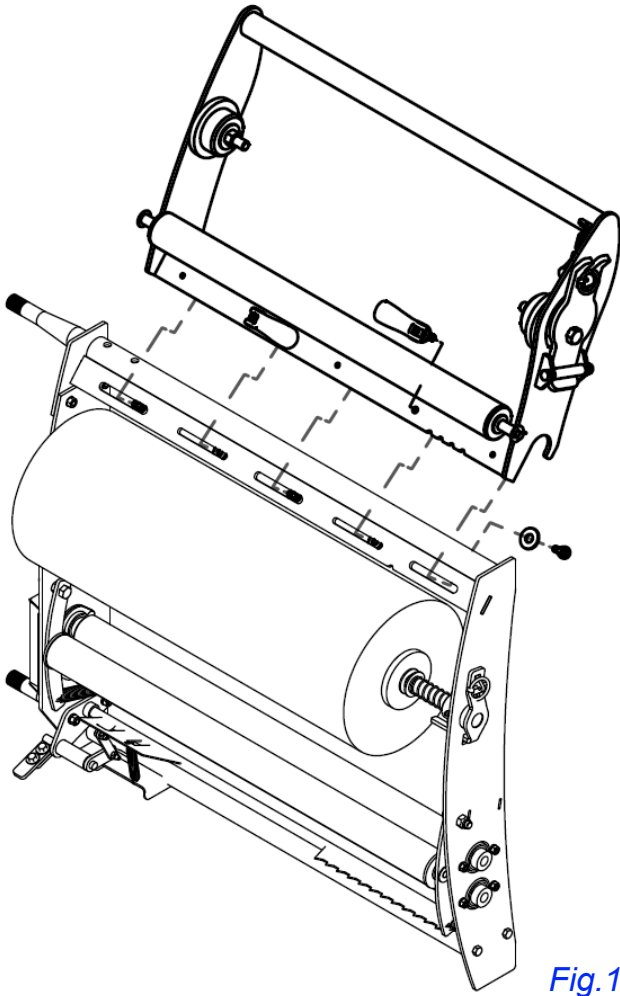

Fig.1

Twin Wrap Kit Adjustments

1. Lift and turn handles to loosen twin wrap.
2. Slide twin wrap left or right to increase or decrease the plastic film layer overlap.
3. Turn handles to tighten twin wrap and push them down to lock in place.

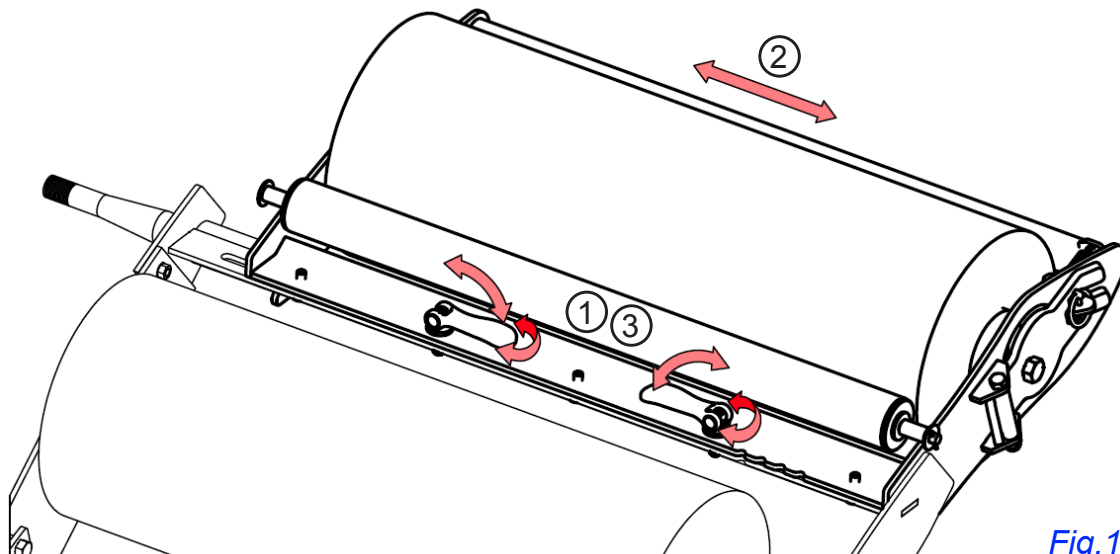
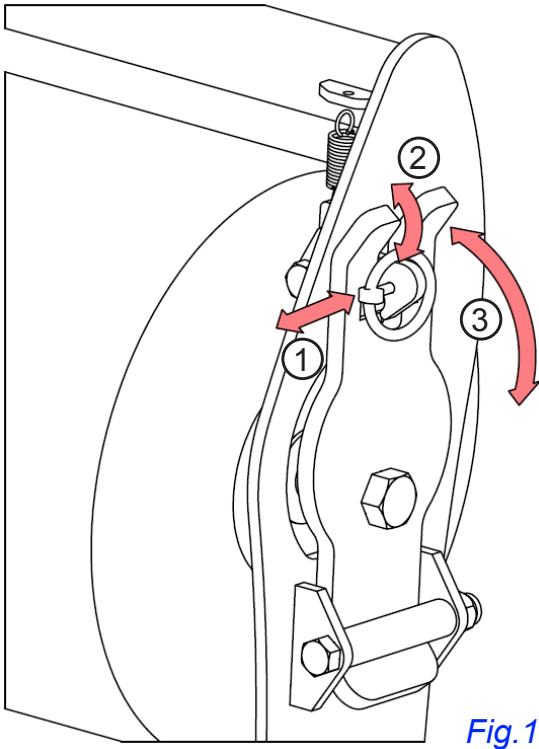

Fig.1

Twin Wrap Plastic Film

See [Fig.1](#) to change twin wrap plastic rolls:



1. Remove linchpin.
2. Lift latch to unlock spool holder.
3. Pull spring spool holder out enough to remove the empty plastic roll from the spools.
4. Insert new plastic film roll into front spool holder.
5. Align other end of plastic film roll with spring spool holder.
6. Push spring spool holder into plastic film roll, ensure latch snaps into locked position.
7. Insert linchpin.
8. Route twin wrap plastic film over the roller and under the existing standard plastic film roll. See [Fig.2](#).
9. Route both overlapping plastic film ends through standard film carrier rollers as specified on [pg.4-4](#).

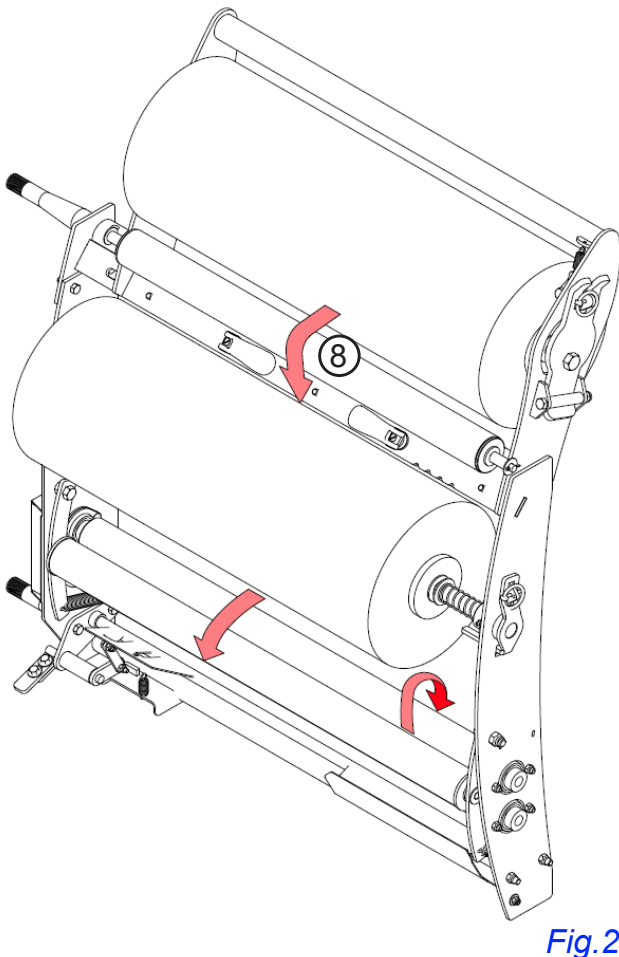

Section 20: Option - Laser Guidance System

Laser Guidance Installation

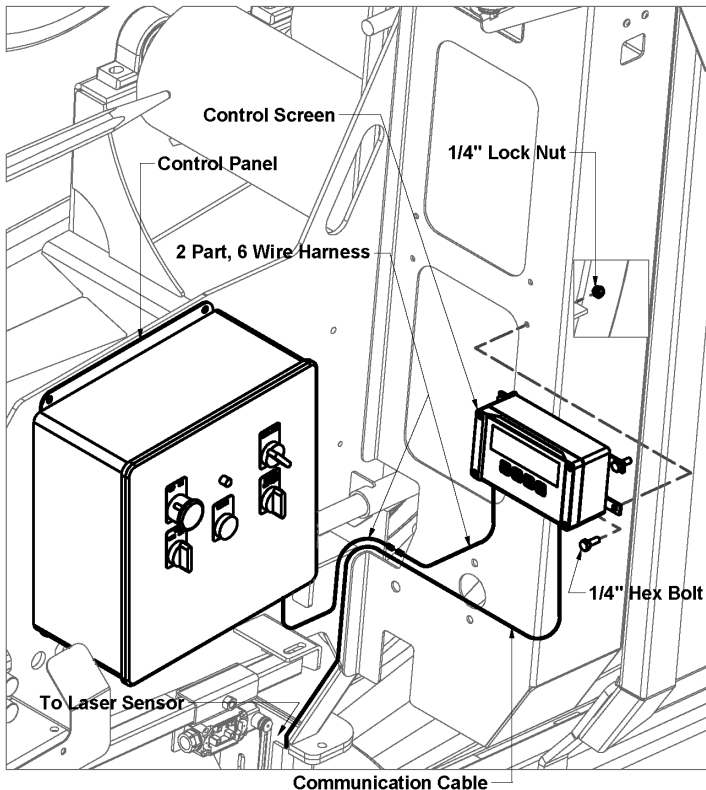

To install your Laser Guidance System on a balewrapper follow these instructions:

1. Position screen in such a way that the 2 part, 6 wire harness can easily reach the control panel. It may be necessary to drill holes in the left door mount to allow mounting of the control screen. Fasten in place with 1/4" bolts and lock nuts.
2. Route the 2 part, 6 wire harness from the control screen, down the door mount and into the control panel.
3. Follow the wiring diagram on [pg. 19-2](#) to connect the 6 wire to their correct terminals within the control panel.
4. The communication cable must be routed down the door mount and hoop brace and along the balewrapper frame to the front steering cylinder. It must then be connected to the mounted laser sensor.

NOTE: It may be possible to route the communication cable along side existing wires.

5. The laser sensor and mount assembly must be mounted to the rod side of the front steering cylinder. The pin holding the front steering cylinder rod end in place will need to be removed to allow the laser sensor mount bracket to slide between the cylinder rod end and the sliding tube lug.

6. Reinstall cylinder pin.

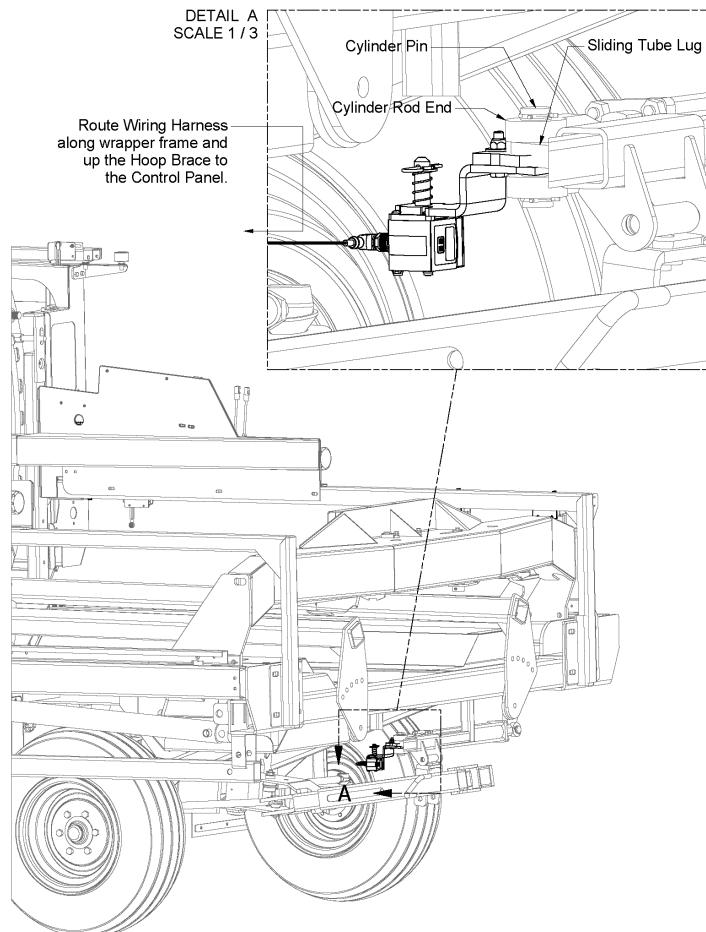

Laser Guidance Wiring

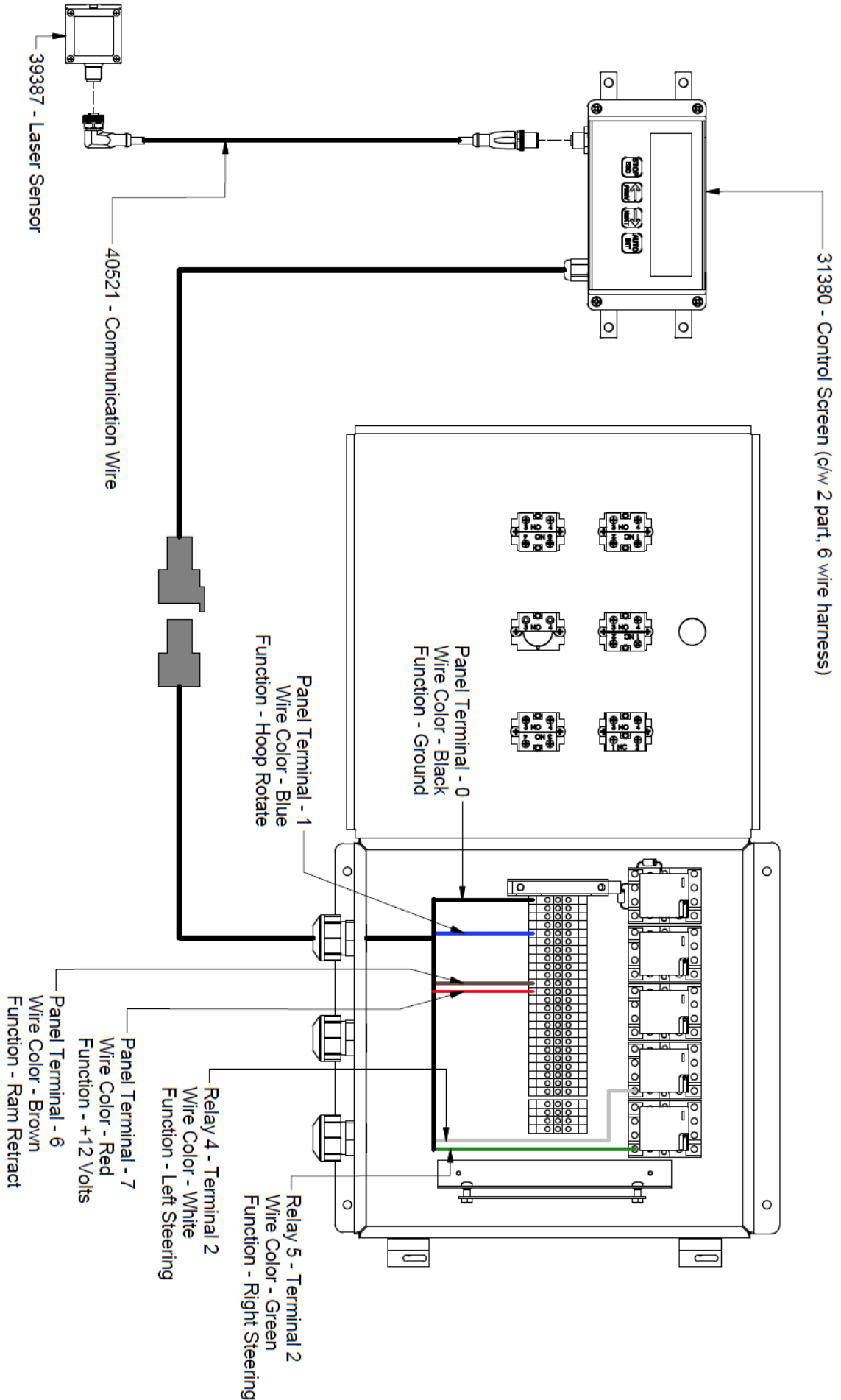

Laser Guidance Adjustment

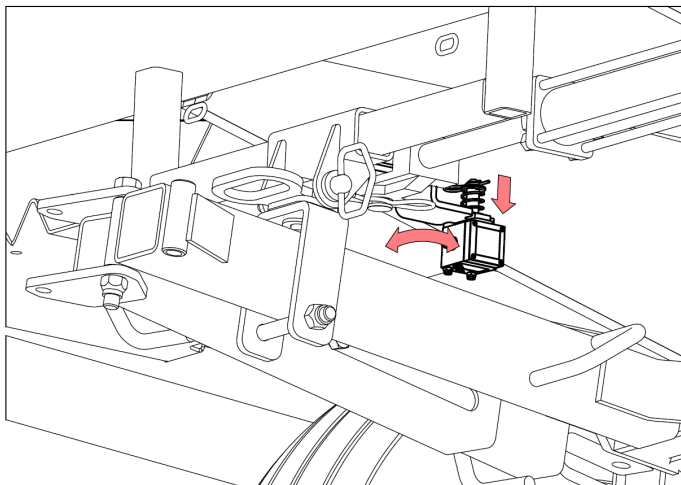

1. The mirrored face of the sensor must be pointing towards the row you want the wrapper to follow. The sensor can be repositioned as needed by pulling down on the sensor, then pivoting it in the correct position.

2. Release the sensor. The machine screw heads holding the sensor to its mounting plate should fit neatly into the pivot plate to lock the necessary position in place.

Laser Guidance Control Screen Functions

Main Menu Screen

The default screen is **Main Menu**. From this screen you can select which side of the wrapper the laser sensor is pointed towards. Use the **PREV** arrow button or the **NEXT** arrow button to toggle between **Steer Left**, **Steer Right**, and **Count Bales**. Press **AUTO - ENT** to select desired option.

NOTE: Press the STOP - ESC button at any time to return to the Main Menu screen.

Laser L Screen

After choosing which side your laser sensor is pointing towards you will be taken to the Laser L screen. Use this screen to alter the current distance between rows. The top right corner value is the targeted distance from bale row (measured in inches) while the lower left value is the current distance from bale row (measured in inches).

Example: Noticing a root in the path of a started row, a farmer uses the Laser L screen and the NEXT arrow button to adjust the targeted distance between the existing bale row and current row from 90" to 96". This creates a slight bend in the row but allows it to move around the root. The farmer then uses the PREV arrow button to get the row back on the desired path.

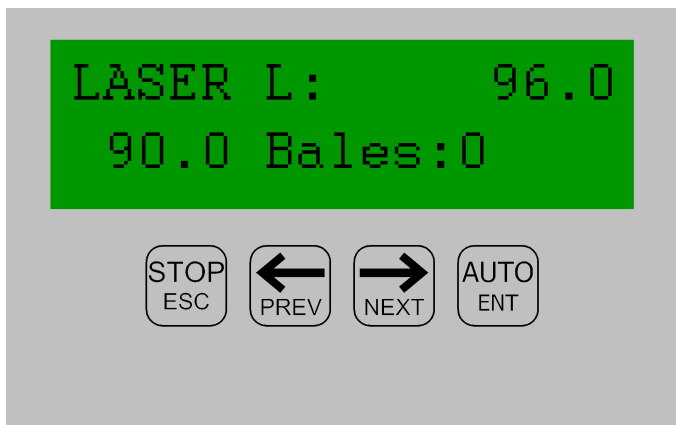
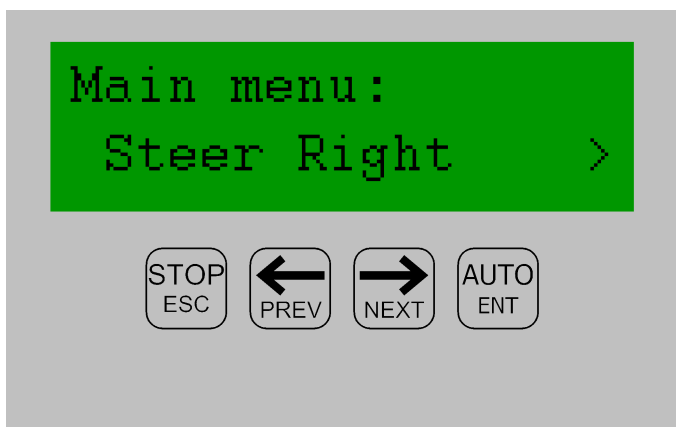

Main Menu: Count Bales Screen

After selecting this option from the Main Menu Screen you will see the current Bale Count.

If you would like to reset bale count to zero simply hit the **NEXT** arrow button followed by the **AUTO - ENT** button, or the **STOP - ESC** button to cancel.

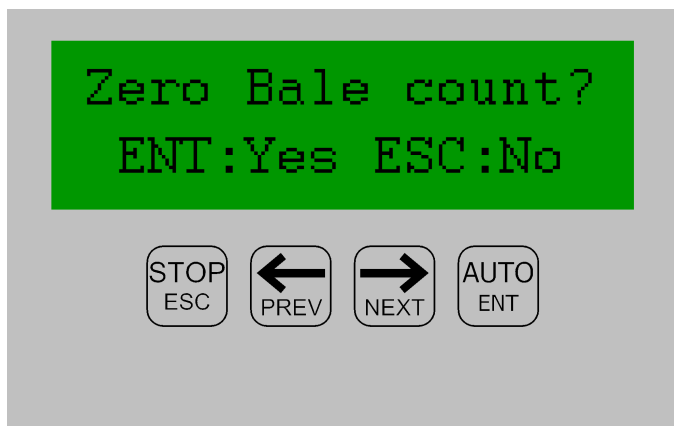
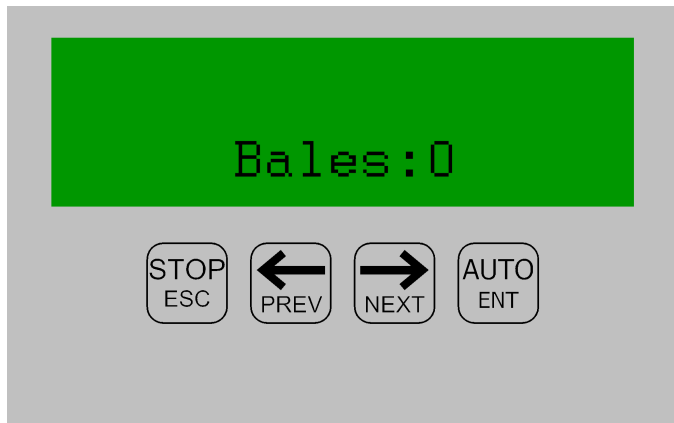
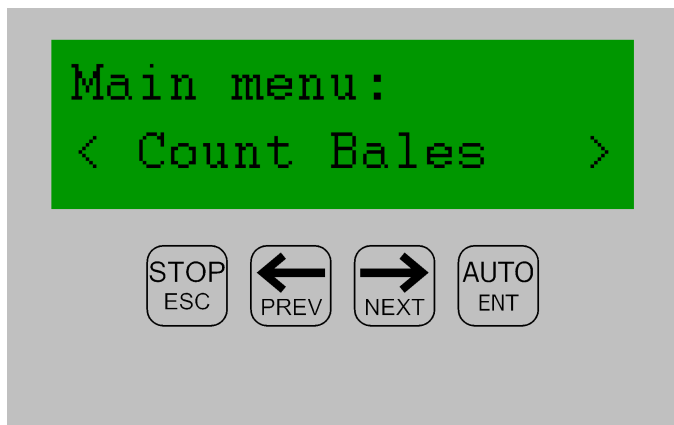

Section 21: Option - Roadflex Suspension Axle

NOTE: Only available for front axle. Decreases stress to machine frame and bale deck while placing bales.

Suspension Axle Installation













WARNING: Do not attempt this installation without properly bracing the machine and blocking wheels to prevent rolling. Install while machine on flat surface.

- Unbolt and remove existing front axle.
- Use hoist and a helper to lift the new axle into position.
- Use hardware from standard front axle to bolt suspension axle in place.

Intentionally Left Blank

Imperial Torque Value Chart

UNIFIED INCH BOLT AND CAP SCREW TORQUE VALUES

SAE Grade and Head Markings	1 or 2 ^b	5	5.1	5.2	8	8.2
	NO MARK 					
SAE Grade and Nut Markings	2	5		8		
	NO MARK 					

T81162 -19-03M4109

Size	Grade 1				Grade 2 ^b				Grade 5, 5.1, or 5.2				Grade 8 or 8.2			
	Lubricated ^a		Dry ^a		Lubricated ^a		Dry ^a		Lubricated ^a		Dry ^a		Lubricated ^a		Dry ^a	
	N-m	lb-ft	N-m	lb-ft	N-m	lb-ft	N-m	lb-ft	N-m	lb-ft	N-m	lb-ft	N-m	lb-ft	N-m	lb-ft
1/4	3.7	2.8	4.7	3.5	6	4.5	7.5	5.5	9.5	7	12	9	13.5	10	17	12.5
5/16	7.7	5.5	10	7	12	9	15	11	20	15	25	18	28	21	35	26
3/8	14	10	17	13	22	16	27	20	35	26	44	33	50	36	63	46
7/16	22	16	28	20	35	26	44	32	55	41	70	52	80	58	100	75
1/2	33	25	42	31	53	39	67	50	85	63	110	80	120	90	150	115
9/16	48	36	60	45	75	56	95	70	125	90	155	115	175	130	225	160
5/8	67	50	85	62	105	78	135	100	170	125	215	160	240	175	300	225
3/4	120	87	150	110	190	140	240	175	300	225	375	280	425	310	550	400
7/8	190	140	240	175	190	140	240	175	490	360	625	450	700	500	875	650
1	290	210	360	270	290	210	360	270	725	540	925	675	1050	750	1300	975
1-1/8	400	300	510	375	400	300	510	375	900	675	1150	850	1450	1075	1850	1350
1-1/4	570	425	725	530	570	425	725	530	1300	950	1650	1200	2050	1500	2600	1950
1-3/8	750	550	950	700	750	550	950	700	1700	1250	2150	1550	2700	2000	3400	2550
1-1/2	1000	725	1250	925	990	725	1250	930	2250	1650	2850	2100	3600	2650	4550	3350

DO NOT use these values if a different torque value or tightening procedure is given for a specific application. Torque values listed are for general use only. Check tightness of fasteners periodically.

Shear bolts are designed to fail under predetermined loads. Always replace shear bolts with identical grade.

^a "Lubricated" means coated with a lubricant such as engine oil, or fasteners with phosphate and oil coatings. "Dry" means plain or zinc plated without any lubrication.

^b Grade 2 applies for hex cap screws (not hex bolts) up to 152 mm (6-in.) long. Grade 1 applies for hex cap screws over 152 mm (6-in.) long, and for all other types of bolts and screws of any length.





















Fasteners should be replaced with the same or higher grade. If higher grade fasteners are used, these should only be tightened to the strength of the original.

Make sure fasteners threads are clean and that you properly start thread engagement. This will prevent them from failing when tightening.

Tighten plastic insert or crimped steel-type lock nuts to approximately 50 percent of the dry torque shown in the chart, applied to the nut, not to the bolt head. Tighten toothed or serrated-type lock nuts to the full torque value.

Metric Torque Value Chart

METRIC BOLT AND CAP SCREW TORQUE VALUES

Property Class and Head Markings	4.8		8.8		9.8		10.9		12.9	
										
Property Class and Nut Markings	5		10		10		10		12	
										

Size	Class 4.8				Class 8.8 or 9.8				Class 10.9				Class 12.9			
	Lubricated*		Dry*		Lubricated*		Dry*		Lubricated*		Dry*		Lubricated*		Dry*	
	N-m	lb-ft	N-m	lb-ft	N-m	lb-ft	N-m	lb-ft	N-m	lb-ft	N-m	lb-ft	N-m	lb-ft	N-m	lb-ft
M6	4.8	3.5	6	4.5	9	6.5	11	8.5	13	9.5	17	12	15	11.5	19	14.5
M8	12	8.5	15	11	22	16	28	20	32	24	40	30	37	28	47	35
M10	23	17	29	21	43	32	55	40	63	47	80	60	75	55	95	70
M12	40	29	50	37	75	55	95	70	110	80	140	105	130	95	165	120
M14	63	47	80	60	120	88	150	110	175	130	225	165	205	150	260	190
M16	100	73	125	92	190	140	240	175	275	200	350	255	320	240	400	300
M18	135	100	175	125	260	195	330	250	375	275	475	350	440	325	560	410
M20	190	140	240	180	375	275	475	350	530	400	675	500	625	460	800	580
M22	260	190	330	250	510	375	650	475	725	540	925	675	850	625	1075	800
M24	330	250	425	310	650	475	825	600	925	675	1150	850	1075	800	1350	1000
M27	490	360	625	450	950	700	1200	875	1350	1000	1700	1250	1600	1150	2000	1500
M30	675	490	850	625	1300	950	1650	1200	1850	1350	2300	1700	2150	1600	2700	2000
M33	900	675	1150	850	1750	1300	2200	1650	2500	1850	3150	2350	2900	2150	3700	2750
M36	1150	850	1450	1075	2250	1650	2850	2100	3200	2350	4050	3000	3750	2750	4750	3500

DO NOT use these values if a different torque value or tightening procedure is given for a specific application. Torque values listed are for general use only. Check tightness of fasteners periodically.

Shear bolts are designed to fail under predetermined loads. Always replace shear bolts with identical property class.

Fasteners should be replaced with the same or higher property class. If higher property class fasteners are used, these should only be tightened to the strength of the original.

* "Lubricated" means coated with a lubricant such as engine oil, or fasteners with phosphate and oil coatings. "Dry" means plain or zinc plated without any lubrication.

Make sure fasteners threads are clean and that you properly start thread engagement. This will prevent them from failing when tightening.

Tighten plastic insert or crimped steel-type lock nuts to approximately 50 percent of the dry torque shown in the chart, applied to the nut, not to the bolt head. Tighten toothed or serrated-type lock nuts to the full torque value.

Index

Advantages to High Moisture Hay	I
Advantages to Wrapping Bales	I
After Wrapping7-4
Auto Mode Test Run6-3
Auto Wrap Mode7-2
Bale Ram Limit Switch Adjustments4-2
Bale Ram Limit Switch Functions4-1
Bales1-1
Balewrapper Starting7-1
Battery Hookup6-2
Control Panel Functions.3-1
Control Panel Functions - Optional3-2
Control Panel Relays	11-1
Dealer Installation6-1
Dimensions1-1
Directional Control Valve Functions5-1
Disconnect Battery8-1
Dispatch Arm Installation	16-1
Dispatch Arm Operation.	16-2
Door Switch Adjustment.4-1
Electric Hydraulic Sequence of Operation	11-1
Ending Bale Row7-3
Feeding from Bale Row9-1
Film Sensor Installation	14-1
Flow Control Adjustment5-1
Fuel Shutoff - 13hp Engine Only8-1
Grease Points	10-1
Grease Timeline	10-2
Guide Roller Kit Installation.	17-1
Hydraulic Oil	10-2
Hydraulic Oil Filter	10-2
Imperial Torque Value ChartVII
Inline Wrapper 3 Year Limited Warranty Statement (<i>Excludes Individual Wrapper</i>)	//
Laser Guidance Adjustment	20-3
Laser Guidance Control Screen Functions	20-3
Laser Guidance Installation	20-1
Laser Guidance Wiring	20-2
Laser L Screen	20-3
Lighting2-2
Main Menu: Count Bales Screen	20-4
Main Menu Screen	20-3
Manifold Port Connections	11-2
Manual Mode Test Run6-3
Metric Torque Value ChartVIII

Night Light Kit Installation	18-1
Night Light Kit Operation	18-1
Observe Maximum Transport Speed	8-2
Operator's Manual	1
Optional Remote Start	7-2
Option - Remote Control Start Add-on*	13-2
Orientation	1-2
Personal Protective Equipment	2-2
Plastic Film Disposal	9-1
Plastic Film Installation	4-3
Plastic Film Sensor Adjustment	14-2
Plastic Film Sensor Operation	14-2
Power Drive Installation - Dual	12-3
Power Drive Installation - Hydraulic Control Circuit	12-1
Power Drive Installation - Single	12-2
Power Drive Operation	12-4
Power Unit Hookup	8-1
Pre-Operating Inspection	6-3
Remote Control Function	13-1
Remote Control Installation	13-1
Remote Start Add-on Installation	13-2
Remote Start Add-on Operation	13-3
Safety Decal Illustrations	2-5
Safety Decal Locations	2-4
Safety Guidelines	2-1
Safety Signal Words / Safety Messages	2-1
Section 1: General Information	1-1
Section 2: Safety	2-1
Section 3: Control Panel	3-1
Section 4: Adjustments	4-1
Section 5: Hydraulic Functions	5-1
Section 6: Setup	6-1
Section 7: Operation	7-1
Section 8: Transporting Balewrapper	8-1
Section 9: Feeding	9-1
Section 10: Maintenance	10-1
Section 11: Diagnostics	11-1
Section 12: Option - Power Drive	12-1
Section 13: Option - Remote Control	13-1
Section 14: Option - Plastic Film Sensor	14-1
Section 15: Option - Wireless Plastic Film Sensor	15-1
Section 16: Option - Dispatch Arm	16-1
Section 17: Option - Guide Roller Kit	17-1
Section 18: Option - Night Light Kit	18-1
Section 19: Option - Twin Wrap Kit	19-1
Section 20: Option - Laser Guidance System	20-1

Section 21: Option - Roadflex Suspension Axle	21-1
Serial Number 1
Slow Moving Vehicle (SMV) Sign8-2
Starting a Bale Row7-1
Steering.7-2
Steer Speed Needle Valve Adjustment5-2
Stopping Cycle7-2
Storage8-2
Suitable Wrapping Timeframe1-1
Suspension Axle Installation	21-1
Terminology1-2
Tire Pressure8-2
Transport Lock8-1
Troubleshoot Plastic Film and Carriers	11-3
Twin Wrap Kit Adjustments	19-1
Twin Wrap Kit Installation	19-1
Twin Wrap Plastic Film	19-2
Usage1-1
Wireless Film Sensor Operation	15-2
Wireless Film Sensor Receiver Board Installation.	15-1
Wireless Film Sensor Test	15-2
Wireless Film Sensor Transmitter Installation	15-2
Wrapping Site6-3
Wrapping Straw1-1



WARNING

The engine exhaust from this product contains chemicals known in the state of California to cause cancer, birth defects, or other reproductive harm.

TUBE•LINE™