

Tube-Line Bale Wrapper TL 5500AX2

Operator's Manual



TUBE•LINE™
MANUFACTURING LTD.

28017 (06/03/11)

Serial # Decal

SERIAL NUMBER

The implement serial number is located on the front of the frame. This number helps us to track changes and improvements and must be mentioned when ordering parts or requesting service. For your convenience, a space has been provided inside the front cover of this manual to record the serial number, model number, purchase date, and dealer name.

Model # : _____

Serial # : _____

Date Purchased : _____

Dealer Name : _____

Operator's Manual

Thank you for choosing the Tube-line TL 5500AX2 Bale Wrapper. Our hope is that it will give you many years of productive service. This machine is designed to wrap a continuous line of round bales in a film of plastic.

Please read and understand this manual and the machine before operation.

Warranty and Limitation of Liability

All Equipment is sold subject to mutual agreement that it is warranted by the company to be free from defects of materials and workmanship. But the company shall not be liable for special, indirect or consequential, damages of any kind under this contract or otherwise. The company's liability shall be limited exclusively to replacing or repairing without charge, at its factory or elsewhere, at its discretion. Any material, or workmanship defects which become apparent within one year from the date on which the equipment was purchased, and the company shall have no liability for damages of any kind. The buyer by the acceptance of the equipment will assume all liability for any damages, which may result from the use or misuse by his employees or others.

Warranty coverage is null and void unless Warranty Registration form has been completely filled in and is on file at Tube-Line Manufacturing Ltd.

Safety

Take note! This safety alert symbol is found throughout this manual to call your attention to instructions involving yourself and others working around the machine.

- **Failure to follow these instructions can result in injury or death!**



This symbol means

- **Attention!**
- **Become Alert!**
- **Your Safety is involved!**

Signal Words are used in this book.

Caution: Indicates a potentially hazardous situation that may result in injury.

Warning: Indicates a potentially hazardous situation that could result in serious injury or death.

Danger: Indicates a hazardous situation that needs to be avoided. It is you the operator that needs to be aware of these dangers.

If you have any questions not answered in this manual, please contact your dealer or Tube-line Manufacturing Ltd.

3928 Steffler Rd,
R. R. #4 Elmira
Ontario, Canada
N3B 2Z3

Tel : (519)-664-0488
Fax : (519)-664-0492
e-mail : sales@tubeline.ca



Safety- It's in Your Interest



Safety Guidelines

Safety of the operator is one of our main concerns, however we do hear of some accidents that could have been avoided if some precautions had been taken. To avoid personal injury study the following precautions and insist those working with you or for you, follow them.

In most cases the pictures will have the shielding in place, in some they may be removed, only to show a view behind the shield. Keep all the shields, safety doors in place. If they become faulty and fail to work replace them. They are for your safety, do not operate the equipment with them removed.

Replace any decals that may be missing or that are not readable. Location of the decals is indicated in this manual.

Do not operate this machine while under the influence of drugs or alcohol.

Review the safety instructions with all users annually.

This equipment should not be operated by children, or with those unfamiliar with the operation of the machine. **Do not allow persons to operate this machine until they have read this manual and/or were instructed by a qualified person.**

Do not paint over, remove or deface any safety signs or warning decals on your equipment. Observe all safety signs and practice the instructions on them.

If the bale seems to be larger then the hoop do not try to force the material through as the film spools my touch the bale and break the plastic. If is stalls halfway through you can't back up, you will have to pull the bale apart by hand.



Lighting and marking

This machine is equipped with lights and reflectors as required by the most stringent government and ASAE specifications. They should work with the tractor 7-pin connector.

Safety Decal Location

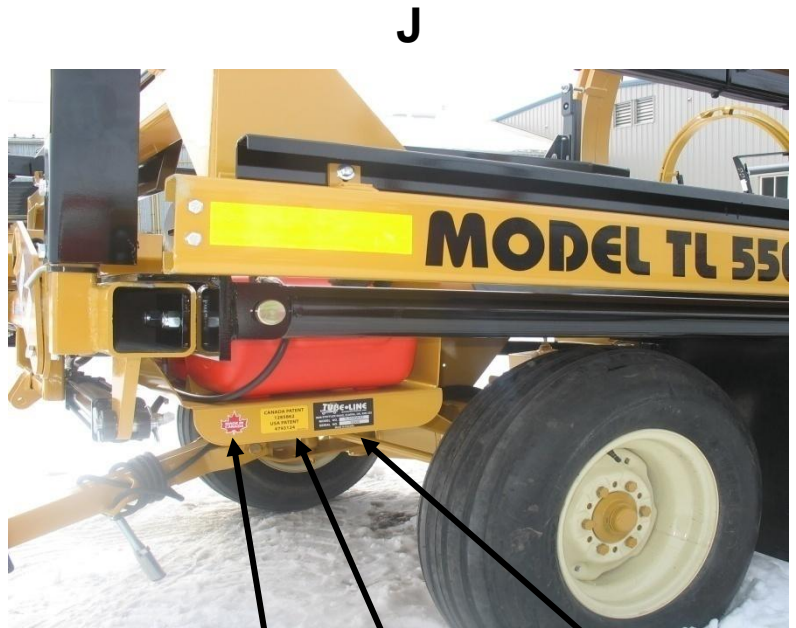
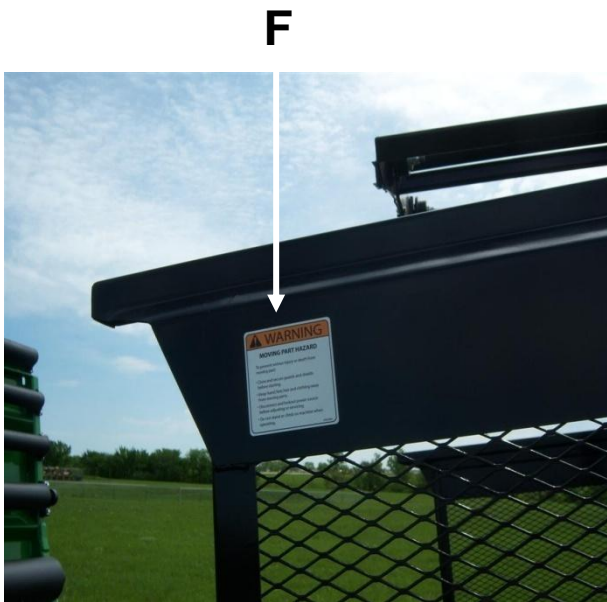

Safety Decal Location



M J A



A J



E

ITEM – A
PART # - 5TBDE23846

WARNING



MOVING PART HAZARD

To prevent serious injury from moving part:

- Do not stand or climb on machine when operating.
- Keep others away.

#DE23846

ITEM – B
PART # - 5TBDE23939

IMPORTANT

Before opening safety door turn control off.

Turn on/off switch before boosting or charging battery.

#DE23939

ITEM – C
PART # - 5TBDE23839

CAUTION

To avoid serious injury:

- Read Operator’s Manual before operating, servicing or repairing equipment. Follow all safety rules and instructions. (Manuals are available from your selling dealer.)
- Never allow riders.
- Keep bystanders away from equipment during operation.
- Operate from tractor seat only.
- Keep all sheilds in place and good condition.
- Lower equipment to ground, stop engine, remove key and set brake before dismounting tractor.
- Never allow children or untrained persons to operate equipment.

#DE23839

ITEM – D
PART # - 5TBDE23988

DANGER

To prevent serious injury or death

Always turn machine to manual mode before starting engine.

#DE23988

ITEM – E
PART # - 5TBDE23942

WARNING

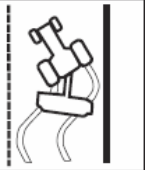

Do not exceed this implement’s maximum transport speed of 32km/h (20mph)

Exceeding this speed may result in loss of control during transport or braking and serious injury or death.

Transport only with a properly ballasted tractor and a properly attached safety tow chain. Do not transport with a motor vehicle. Reduce speed and use additional caution when on inclines, towing under adverse surface conditions, and turning.

#DE23942

ITEM – F
PART # - 5TBDE23845



WARNING

MOVING PART HAZARD

To prevent serious injury from moving part:

- Close and secure guards and shields before starting.
- Keep hand, feet, hair and clothing away from moving parts.
- Disconnect and lockout power source before adjusting or servicing
- Do not stand or climb on machine when operating.

#DE23845

ITEM – G
PART # - 5TBDE23971

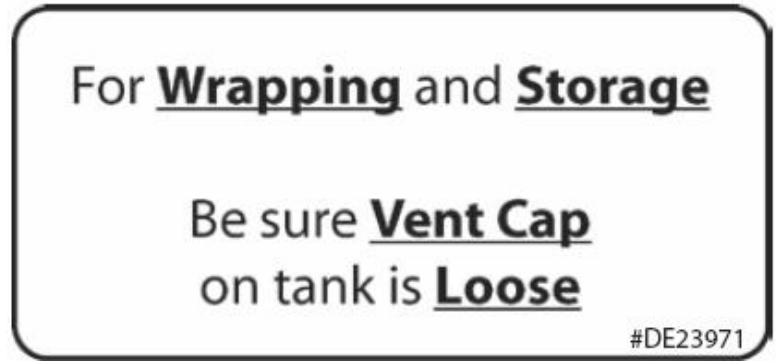

For **Wrapping** and **Storage**

Be sure **Vent Cap**
on tank is **Loose**

#DE23971

ITEM – H
PART # - 5TBDE23847

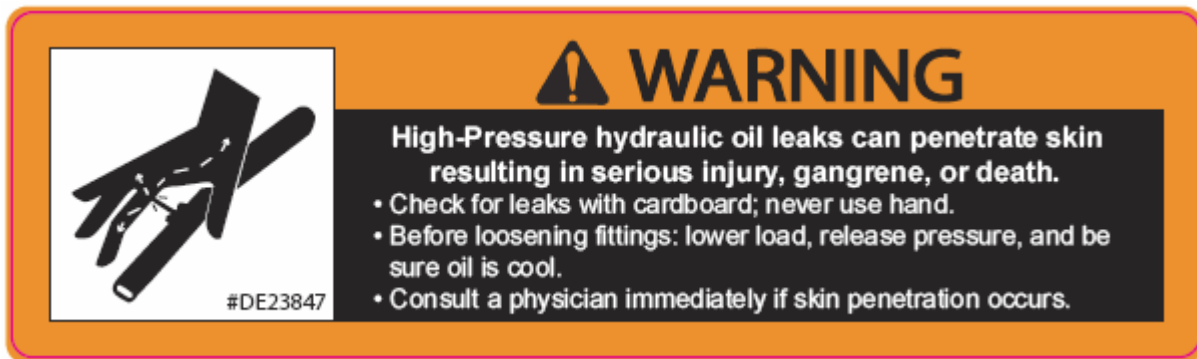

WARNING

High-Pressure hydraulic oil leaks can penetrate skin resulting in serious injury, gangrene, or death.

- Check for leaks with cardboard; never use hand.
- Before loosening fittings: lower load, release pressure, and be sure oil is cool.
- Consult a physician immediately if skin penetration occurs.

#DE23847



- Keep safety signs clean and legible at all times
- Replace safety signs that are missing or illegible
- Decals are available through your Tubeline Dealer

Safety Decal Location

ITEM - I (Both Sides of the Machine)
PART # - DERED



ITEM - J (Both Sides of the Machine)
PART # - DEAMBER



ITEM - K
PART # - DECANADA

ITEM - L
PART # - DE23941



ITEM - M
PART # - DE23978



Remember

Your best assurance against accidents or damage to the machine is to know how it operates. If you do not understand a portion of the manual or a function of the wrapper, please contact your dealer or an experienced operator.



Before Operation

- Carefully study and understand the manual or be trained by an experienced operator.
- Do not wear loose clothing that may get caught in moving parts. Visually inspect the machine to make sure no parts are loose or missing. Be sure that no tools are left on the machine.
- Make sure no hay is lying on the engine and that the cooling fins are not clogged with dust and hay (**this could cause a fire**)
- Do not hurry the learning process. Be familiar with one part before trying the next part.
- Practice by running the machine through its paces, first in manual mode with no bales in the machine until you are comfortable and familiar with the operation. After you become familiar with the operation, switch the machine to Auto mode. Use a stick and push the table switch down to start the cycle. Do not reach in and push the switch paddle down by hand.

Operating the Model TL 5500AX2 Tube-line Bale Wrapper

Big Bale Silage

The objective of big bale silage is to provide high quality forage using a minimum of equipment. To do this, crop must be cut at the correct stage of maturity, wilted, baled tightly and wrapped air tight, using a good quality stretch wrap.

The Tube-line wrapper makes timely harvest possible by reducing the dependence on the weather. It is much easier to get to wilt silage than to make dry hay. This also extends the working day, as the correct moisture to bale extend earlier and later in the day.

Bales

Well-shaped firm bales are necessary for successful wrapping, using a hard-core baler. Bales are best wrapped as soon as possible after baling. If bales are left unwrapped they will sag and loose shape. Heating will start soon after baling and protein quality will be lost. It is desirable to wrap within four hours. In an emergency such as rain, the bales can be left 12 to 16 hours.

Moisture

Successful silage can be made over a wide moisture range. In general, 40 to 50% moisture is satisfactory for dairy cows. Some beef farmers prefer 60 to 70% moisture as it limits intake. A good rule of thumb is to dry "Half-way to Hay".

Drier silage gives you

1. Lighter bales to handle.
2. More desirable fermentation with fewer odors
3. Less freezing in the winter
4. Higher dry matter intake

Wrapping Site

Select a site that will allow room to make an adequate bale row length. The TL 5500AX2 is a very fast wrapper, but requires time to set up and move to a new line. There should be space for at least 50 bales in a row.

Select a site that is accessible in winter conditions and does not flood in the spring.

A firm surface is necessary for the successful operation of the Tube-line wrapper. Avoid soft ground, as the wrapper will not move forward smoothly if it is sinking into the ground. Wrap on level ground or a slight uphill grade.

A site that is free from grass and debris will be less likely to attract rodents that can damage the plastic.

Bale Size

Round Bales - The TL 5500AX2 will wrap bales up to 5' x 5 ½'. It will wrap all sizes smaller than this dimensions as well.

Remember when making big bale silage the bales will be heavier than dry hay. This puts extra strain on loading and transporting equipment. Also, bales will be heavier when feeding out and may have to be moved on wet ground or snow. As a result most operators reduce silage bale diameter to 4-4 ½', even though the wrapper will handle larger size.

Square Bales - The TL 5500AX2 will wrap most sizes of square bales. The length should be reduced to 5'. This is to allow the bales to be placed on the bale receiver. This is also the maximum length advisable to handle big square bales of silage.

Bales, which are approximately 4' wide and 2' high can be stacked two high for wrapping, **however there is one drawback**, the ends of the bales tend to be rounded somewhat and will form an air tunnel the full length of the row.

Bales which are approximately 3' x 3', do not stack well. These may be wrapped in a single tier of bales.



Recommended Operating Procedure

We suggest the following method of operating the TL 5500AX2 Tube-line Wrapper

- Park the wrapper where you want the end of the row to be, facing in the appropriate direction with wrapper in up position.
- Apply parking brake and fold in the first section of the tongue and fasten the bracket into the hydraulic steering slider with the pin that held the tongue.



Danger : To prevent injury !

Prior to lowering the tail section, be sure to check that all bystanders are standing clear !!

- Lower the tail section using the manual operating valve



Caution!! Be Safe

Never ride on the machine while being used or transported.

Never climb on the table or inside the wrap chamber **with the Engine running.**

Turn control panel to “man” or stop the engine when changing plastic rolls. Never leave it in “auto” as your helper may set a new bale on the table or press the start button on the remote.

Installation of Plastic



Danger!! Stop Engine ! Before attempting to install plastic.

Plastic from the factory has a natural tack on the inside. In the event of the plastic being stored for an extended period of time the tack may migrate to the opposite side. To test for tacky side fold plastic inside to inside and pull apart. Fold opposite way (top to top) to determine tackier side.

The roll of plastic should be installed with the tack on the inside of the plastic film next to the bale silage. The plastic then passes over the slave roller and is threaded through the two metal rollers on the Tensioner as shown in the diagram.

The two metal stretcher rolls rotate at different speeds. This causes the plastic to be stretched. It is very important that the plastic goes over the slow roller first and the faster roll second.

If there is any question, which is the faster roller:

1. Turn one roller by hand and watch the speed of the other roller, this should help you determine which is the fast and slow roller.

When the plastic is installed correctly, it should stretch tight on the bale to form a smooth tube.

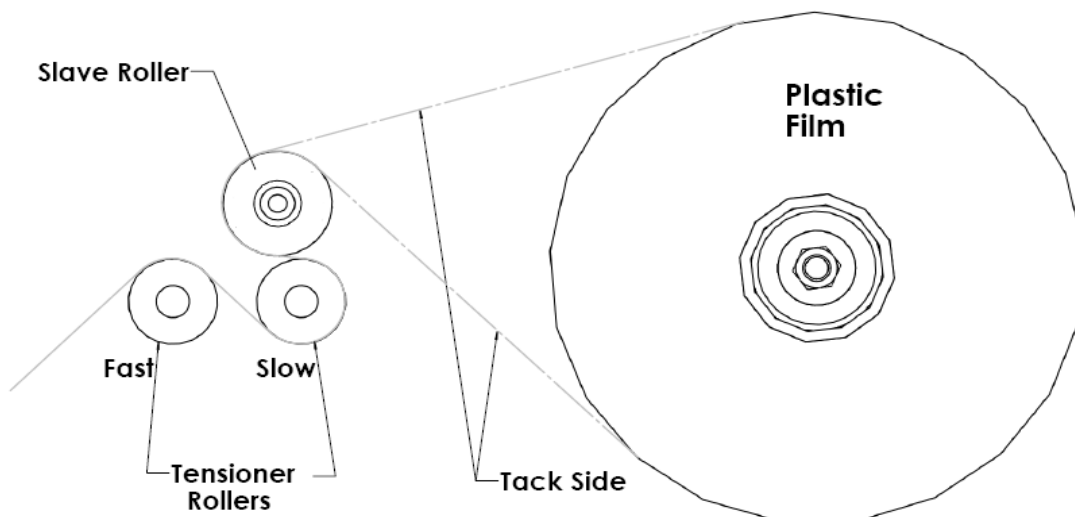

Trouble Shooting Plastic Installation

1. Wrinkles in the plastic with seams between layers easily visible
Check to determine if the plastic is properly routed through the Tensioner rollers.
2. Plastic tears between the Tensioner and the bale

Film spool holders: not turning freely. Lubricate and turn by hand until free.

Slave roller not turning freely. Lubricate and turn by hand until free.

Tensioner rolls not turning freely: Loosen the bolts holding the bearing and check if this makes a difference. It may be that the bearings have too much end pressure, in this case re-tighten the bearings and loosen the locking collar on the roller shaft this will allow the shaft to slide in the bearing; re-tighten the bearing collar. The gears can also be meshed too tight; this can be fixed by slightly loosening one set of bearing bolts and using a hammer and punch lightly tap the bearing away from the other roller.

Caution - Do not use a hammer on the aluminum stretcher rolls.

Poor quality plastic: Use a brand with good tear resistance.

Tack build up on the rollers: Particularly in hot weather. Clean the Tensioner with warm soapy water.

Plastic roll is too hot: In very hot weather the plastic can become soft if left in the sun for long periods of time. In these conditions, the spare rolls should be kept in the shade. After the rolls have been installed on the machine one can be parked on the bottom and a cover can be placed on the top one.

Rolls of plastic may catch on the bottom of the bale. If bales are misshaped the roll of plastic may drag on the bottom of the bale, causing the plastic to break.

If wrapper is equipped with electric automation

Switch the control to "Man"



Danger!! When the machine is manual mode the safety switches and the film sensor Do Not Function.

- Test the hydraulics by rotating the hoop and moving the ram back and forth.
- Install the roll of plastic according to the Plastic Installation diagram.

Caution! Close safety doors after installing plastic to avoid injury.

Caution! Round bale are heavy and silage bales are even heavier. Use only bale-handling equipment. Keep bales low when turning loader.

Bale Guide Bars/ Riser

The bale guide bars are designed to align the round bales as the bales are set on the wrapper. These bars should be adjusted to the narrow setting to wrap round bales up to 5' diameter. For larger bales use the wide setting.

Caution! It is important that the bale sit firmly on the deck, as the bale spears should deflect the hay somewhat. Failure to do this may cause the plastic to stick to the spears and tear the plastic inside the bale.

To Wrap Bales with TL 5500AX2

Before the first bale that will stay on the line is placed on the wrapper, place an end cap on the bale. (Check with your plastic supplier for suggestions.)

- Pull about 4 ft of plastic through each stretcher and tie it under the twine on the bale, or tie it in the slots on the hoop brace (both sides)
- With the control panel switch “auto/man” set to “man” turn “forward switch to advance the bale without the plastic stretcher applying plastic.
- As the bale is pushed through the hoop, start the hoop rotating to apply plastic by pushing in the “Rotate” button.
- When the ram hits the switch at the end of the stroke the forward motion on the cylinder will stop. (This switch can be move on the slider arm to accommodate your needs). More about this later.
- With the switch set to “man” the switch buttons will have to be turned and/or pushed and held, when you let them go the function will stop.
- Turning the reverse switch will retract the ram and open the bale pusher to accommodate the next bale.
- Wrap the 1st few bales in “man” until the first bale overhangs at rear of machine by 6 inches. Lower machine to the ground and **disengage brake. If equipped with a power drive, disengage lever.**

Note! You may want to leave some weight on the wheels until the wrapper starts moving to avoid bales from sliding on the ground.

- After you have wrapped a few bales in this way, switch “auto/man” switch to “auto” and place bale on the bale table. As the bale depresses the table trigger ram will start automatically. Adjust the second slider switch to start the wrap cycle at the same time that the bale makes contact with bales on the machine.



Warning!!

To stop the cycle: After the cycle has started in the automatic mode, turn “**auto/man**” switch to “man” (or if you have the optional remote kit, push the “stop” button on the hand unit to stop the cycle. After the problem is rectified, finish the rest of the cycle in the “man” mode and then return to “auto” mode. (If you press start button on the hand unit it will also start the ram forward again except if the ram had passed the hoop start switch the hoop will not start with the ram).



For safety reasons, safety switches are installed in the doors. In “auto” mode the safety doors must be closed for the machine to work. In “man” these switches are bypassed.



Steering

This wrapper is equipped with hydraulic steering. The purpose of this is to keep the wrapper operating in a straight line or to direct the wrapper around obstacles. If the ground is uneven or the wrapper is operated on the side of a hill, then it can drift out of line. The loader operator is usually able to detect if the wrapper is not moving in the desired direction. When steering around obstacles in the wrapping path do not make sharp turn as this prevents the bales from being tightly packed together. The steering speed can be adjusted with the needle valve at the manifold block.

- When starting a row, align the wrapper in the desired direction for the row and ensure the steering is in the center position.



Optional- Remote Control

With the remote control the machine can be controlled with a hand held unit. The table trigger switch should be unplugged. When the control panel “auto/man” switch is on “auto” the bale can be placed on the table without the cycle starting. After the bales has been placed on the table and you want the cycle to start, press the start button on the hand unit. The machine will now go through the complete wrap cycle and stop at the end of the cycle. Two of the remote buttons are used to control right and left steering. The fourth button is the remote cycle stop.

Notice- the “on/off” switch on the control panel will turn **off all the electric** current to the **Control Panel and also Engine Stop**. The Honda engine does not have an electric ignition therefore the key can be left “on” without the battery draining. The 20hp engine has an electric fuel valve and the **key** needs to be “**off**” when the engine is not running, as the valve will drain the battery.



Slider Switch

Adjust the second slider switch to start the rotate motor when the bales have made contact. By adjusting the slider switch at the rear of the slider bar, which will stop the ram and the wrap motor, and reverse the ram cylinders. -**TIP**- Adjust the rear switch so that the junction of the 2 bales are in the middle of the wrap chamber. It is possible to adjust the second switch so that the wrap will start just before the bales start moving through the wrap chamber, thereby putting extra plastic on the joint of the bale. The front slider switch is set to stop the ram retract stroke after the engine has throttled before the cylinder bottoms out.



Brake

The brake is operated by using the brake hydraulic valve. Moving the hydraulic lever applies oil pressure to the brakes on the rear wheel. Increase pressure to the point where the bales are firmly packed together. Close the brake valve to maintain positive pressure on the wheels. Open the ball valve and **RELEASE BRAKES** when the row is finished and prior to transporting the wrapper.



Pushing off Bales from the Wrapper

The automatic wrapper will have to be switched to “man” position for pushing the bale off.



Danger!!

The use of automatic setting when pushing off bales can cause severe injury or death.

To push off the bales

Open the bale pusher

Remove the linchpin from the front push plate arms

Unfold the arms to extend the push plate

Remove the linchpin from the top of the arms and swing the X bars onto the pins, replace the linchpin to secure the X bar

Push the bale through the wrapper by using the forward button and wrap button with the automatic machine. Continue pushing the bale through the wrap chamber until you have reached the end of the stroke.

Retract the bale pusher

Refold the push plate arms and secure with linchpins at the front arms

Open the safety doors, remove 2 x 3 tube from the Hydraulic tank side of the wrapper and lay it across the top of the Pushoff brackets

Close the pusher a second time to push the bales further off the wrapper.

Open the pusher and move the 2 x 3 tube to the socket at the rear end of the arms. Close the pusher to finish pushing off the bales from the tail.

(NOTICE! The last pushoff brackets are lower than the hill rollers. **BE SURE** the tube is behind the rollers before pushing and remove the tube before opening pusher all the way).

Open the bale pusher, store the 2 x 3 tube in bracket secure with lock pin

Undo steering, unfold tongue and insert lock pin.

Make sure the brakes are released before driving away.



Caution

Before moving the wrapper any distance close the fuel valve at the engine!

As the machine is towed it will bounce and shake, as it does this the carburetor float will let too much fuel into the system. Raw fuel can get into the engine cylinder and wash the cylinder walls down and end up in the engine oil.



Pushing off Bales from the Wrapper

The automatic wrapper will have to be switched to “man” position for pushing the bale off.



Danger!!

The use of automatic setting when pushing off bales can cause severe injury or death.

To push off the bales

Open the bale pusher

Remove the linchpin from the front push plate arms

Unfold the arms to extend the push plate

Remove the linchpin from the top of the arms and swing the X bars onto the pins, replace the linchpin to secure the X bar

Push the bale through the wrapper by using the forward button and wrap button with the automatic machine. Continue pushing the bale through the wrap chamber until you have reached the end of the stroke.

Retract the bale pusher

Refold the push plate arms and secure with linchpins at the front arms

Open the safety doors, remove 2 x 3 tube from the Hydraulic tank side of the wrapper and lay it across the top of the Pushoff brackets

Close the pusher a second time to push the bales further off the wrapper.

Open the pusher and move the 2 x 3 tube to the socket at the rear end of the arms. Close the pusher to finish pushing off the bales from the tail.

(NOTICE! The last pushoff brackets are lower than the hill rollers. **BE SURE** the tube is behind the rollers before pushing and remove the tube before opening pusher all the way).

Open the bale pusher, store the 2 x 3 tube in bracket secure with lock pin

Undo steering, unfold tongue and insert lock pin.

Make sure the brakes are released before driving away.



Caution

Before moving the wrapper any distance close the fuel valve at the engine!

As the machine is towed it will bounce and shake, as it does this the carburetor float will let too much fuel into the system. Raw fuel can get into the engine cylinder and wash the cylinder walls down and end up in the engine oil.

OBSERVE MAXIMUM TRANSPORT SPEED

The maximum transport speed for this implement is 32 km/h (20 mph).

Some tractors are capable of operating at speeds that exceed the maximum transport speed of this implement. Regardless of the maximum speed capability of the tractor being used to tow this implement, do not exceed the implement's maximum transport speed. Exceeding the implements maximum transport speed can result in: - Loss of control of the tractor/implement combination - Reduced or no ability to stop during braking - Implement tire failure - Damage to the implement structure or its components Use additional caution and reduce speed when towing under adverse surface conditions, when turning, and when on inclines. Do not attempt transport if the fully loaded implement weighs more than 1.5 times the weight of the tractor.

Build-up on Stretchers

When wrapping in hot weather there can be a build-up of adhesive on the stretcher rollers. This can cause the plastic to break. Remove the adhesive with soap and water.

Wrapping Straw

The TL 5500AX2 wrapper can be used to weather- protect straw.

Only two layers of plastic are necessary.

If the straw is dry, it may be wrapped continually without spaces. Straw that has some moisture is best wrapped with spaces in the plastic.

After Wrapping

After wrapping, inspect the rows of silage regularly to ensure there is no damage occurring from birds, rodents of livestock.

Feeding Out

With the TL 5500AX2, a loader can pick up bales without cutting the plastic. The plastic breaks away between bales and can be removed from the side of the bales before dropping the bales in the feeder.

Wrapped bales do not spoil as the line is fed. Unlike long bags of bales, the stretch wrap prevents air from moving past the bales and causing the bales at the far end to heat and spoil. As the next bale is undisturbed it will not spoil for one to two days in the warm weather and for at least a week in the cooler weather.

Disposal of Plastic

Users of bale wrappers are encouraged to collect all plastic to prevent it from becoming an environmental problem. Plastic, although bulky, is inserted in a landfill and will not pollute the ground water. Manufactures are making serious efforts to economically recycle silage plastic.

Use of recycling service when available. Please do not burn the plastic!

Collect and dispose all plastic in an Environmentally Friendly manner.

Remember the air and the ground that you contaminate is your visible footprint for many generations!

Unsightly used silage film will encourage complaints.

Diagnosics

Electric Solenoid valves can be manually operated by pushing a small punch into the end of spool and holding it in. **Do Not Use a Hammer!!**

Caution Stay Away From Hoop When Engine Is Running

Inside of Control Panel control relays are numbered CR1 to CR5 from left to right.

Relay CR1 is wired to table trigger. CR1 will activate solenoid valve to extend ram cylinder. CR2 is wired to switch at the front slider, when ram is extended to this switch CR2 will close, energizing the wrap motor valve. Ram cylinder will extend and wrap motor will turn until ram comes in contact with slider switch at rear, then CR1 and CR2 will turn off and CR3 will turn on. Wrap motor will stop and ram cylinder will retract until ram cylinder trips the limit switch at the front end of table. All control will then turn off.

Testing can be done by pushing trigger plate and wait until machine goes through cycle, or you can push small square button on the front of relay 1 and let machine go through cycle.

When control relays are activated a small light goes on inside the relay. When running machine through the cycle and wrapper motor or the cylinders do not work, check flow control valve to see if flow is going to both motor and cylinder.

Engine stopped by grounding ignition, in case of ignition failure make sure that stop switch wire is not grounded to frame and engine is not in stop position. Steering is controlled by switch right/left on control panel through CR4 and CR5 activating coil A or B on steering solenoid valve.

TL 5500AX2

Electric Hydraulic Sequence of Operation

1. With valves in neutral position, control panel on/off switch in off position, engine running fluid is pumped through valve stack and returned to reservoir.
2. Wrap cycle fluid flows from power beyond port on 2 spool valve to flow control, and is split into 2 circuits one circuit goes to double solenoid valve for ram cylinder, the other circuit goes to single solenoid valve for hydraulic motor. By moving flow control handle more or less fluid will flow to cylinder or motor ie. As more fluid flows to cylinder less fluid will flow to motor and vise-versa.
3. Electric control panel- "Man-Auto" switch turned to "Man". Turn "On/Off" switch to On, then red LED will light up indicating 12V power is on at control circuits, with engine running. Turn "Forward" switch in to energize solenoid A on double solenoid valve. Ram cylinder will extend. Turn "Reverse" switch to energize solenoid B on same valve. Ram cylinder will retract. Push Rotate button in and hydraulic motor will run. "For/Rev and Push" buttons have to be held to operate, by releasing them action will stop. Engine throttle has linkage to slow engine down when ram is all the way to the front. Spring on linkage will speed engine up as soon as Ram cylinder starts to extend.
4. When "Man/Auto" switch is turned to Auto, "For/Rev and Rotate" switches no longer function. Depress trigger switch located on bale table, Ram hydraulic valve is energized. The Ram cylinder will extend and engine will speed up. When Ram extends to front slider, this switch will energize the single solenoid valve and turning the wrap motor. When Ram is extended to the limit switch at the end of stroke, single solenoid valve and double solenoid valve "A" will turn off. Solenoid B will energize causing Ram cylinder to retract until it trips limit switch at the front end of bale table, solenoid "B" will turn off, the Ram cylinder will stop and engine will idle down.
5. Steering is done by steering switch, right/left activating steering double solenoid valve A or B. This valve will work in either manual or automatic mode.



Daily Maintenance

Lubricate all grease points



Specifications

Slider Tube : Lightly Grease Once a Week

Hoop Axle : Twice a Day, All 8 Bolts

Ram Axle : Once a Week

Gear Box : 1 or 2 Times Every 2 Months

DO NOT OVER GREASE

Oil Points

Oil these points occasionally to keep the parts moving freely

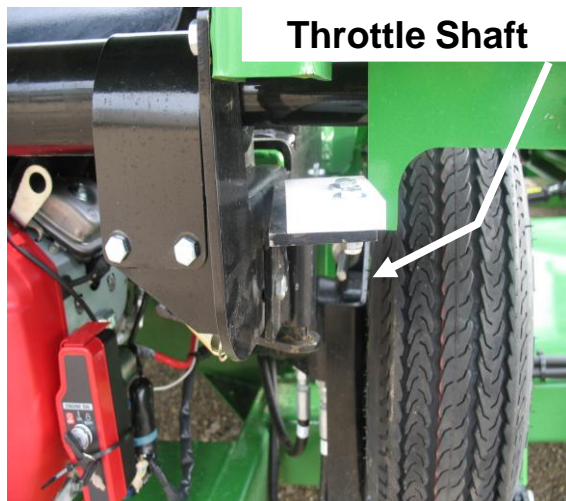

TL 5500AX2 Hoop Assembly

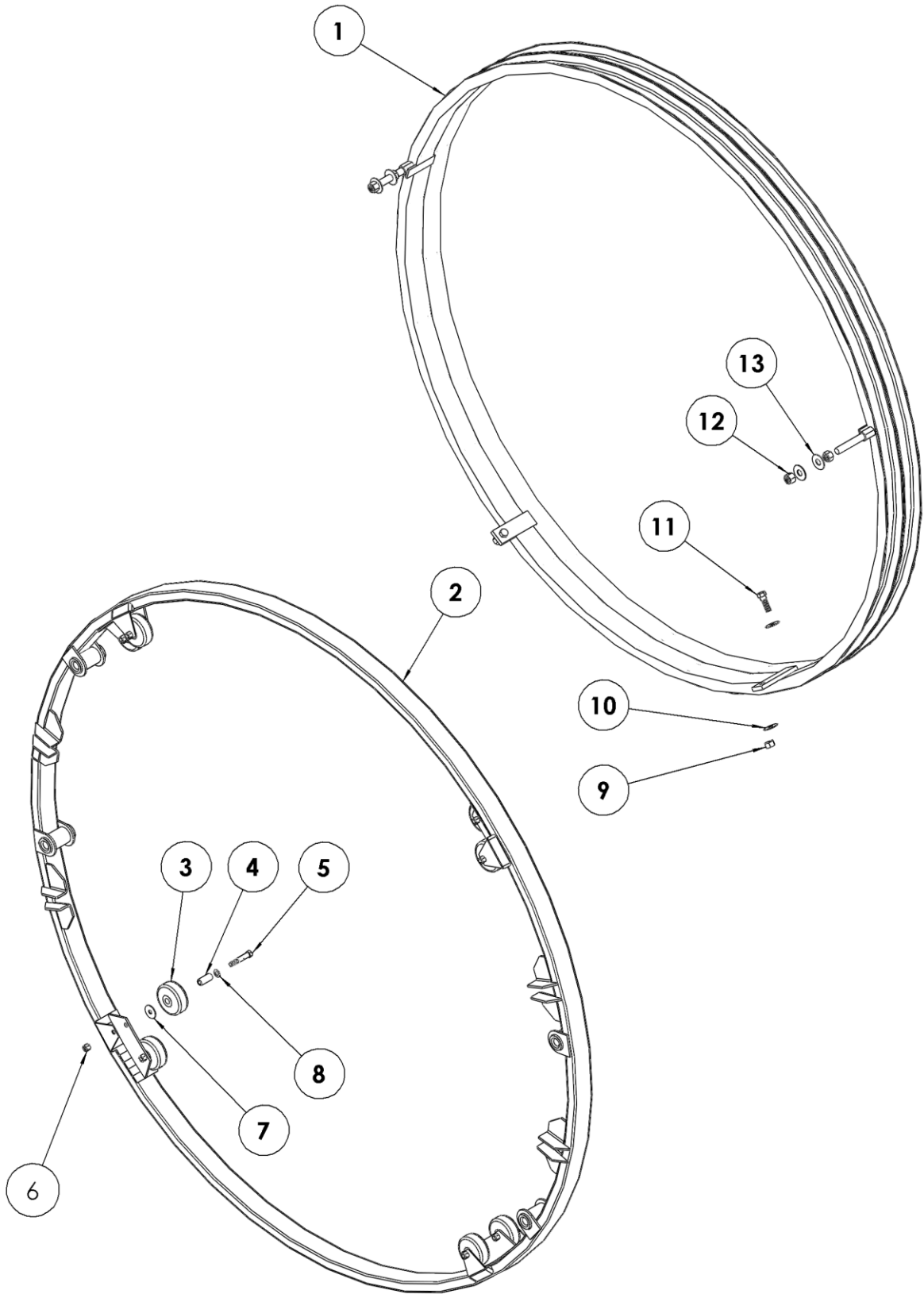

TL 5500AX2 Hoop Assembly

Item	Qty	Part #	Description
1	1	TL550-100-002	Inner Hoop
2	1	TL550-301-001	Outer Hoop
2A		TL5X2-500-101	Complete Outer Hoop (Ref # 2-8)
3	8	TL500-200-014	4" Hoop Wheel
3A		TL5X2-500-102	Complete 4" Hoop Wheel
4	8	TL500-200-016	Spanner
5	8	TL500-100-015	Axle Bolt
6	8	Obtain Locally	½–20 Steel Locknut
7	8	Obtain Locally	½ Fender Washer
8	8	Obtain Locally	½ SAE Washer
9	2	Obtain Locally	5/8-11 Locknut
10	4	Obtain Locally	5/8 Flatwasher
11	2	Obtain Locally	5/8-11 x 2 Bolt Gr.5
12	4	Obtain Locally	3/4-10 Locknut
13	4	Obtain Locally	¾ Flatwasher

TL 5500AX2 Plastic Wrap Carrier

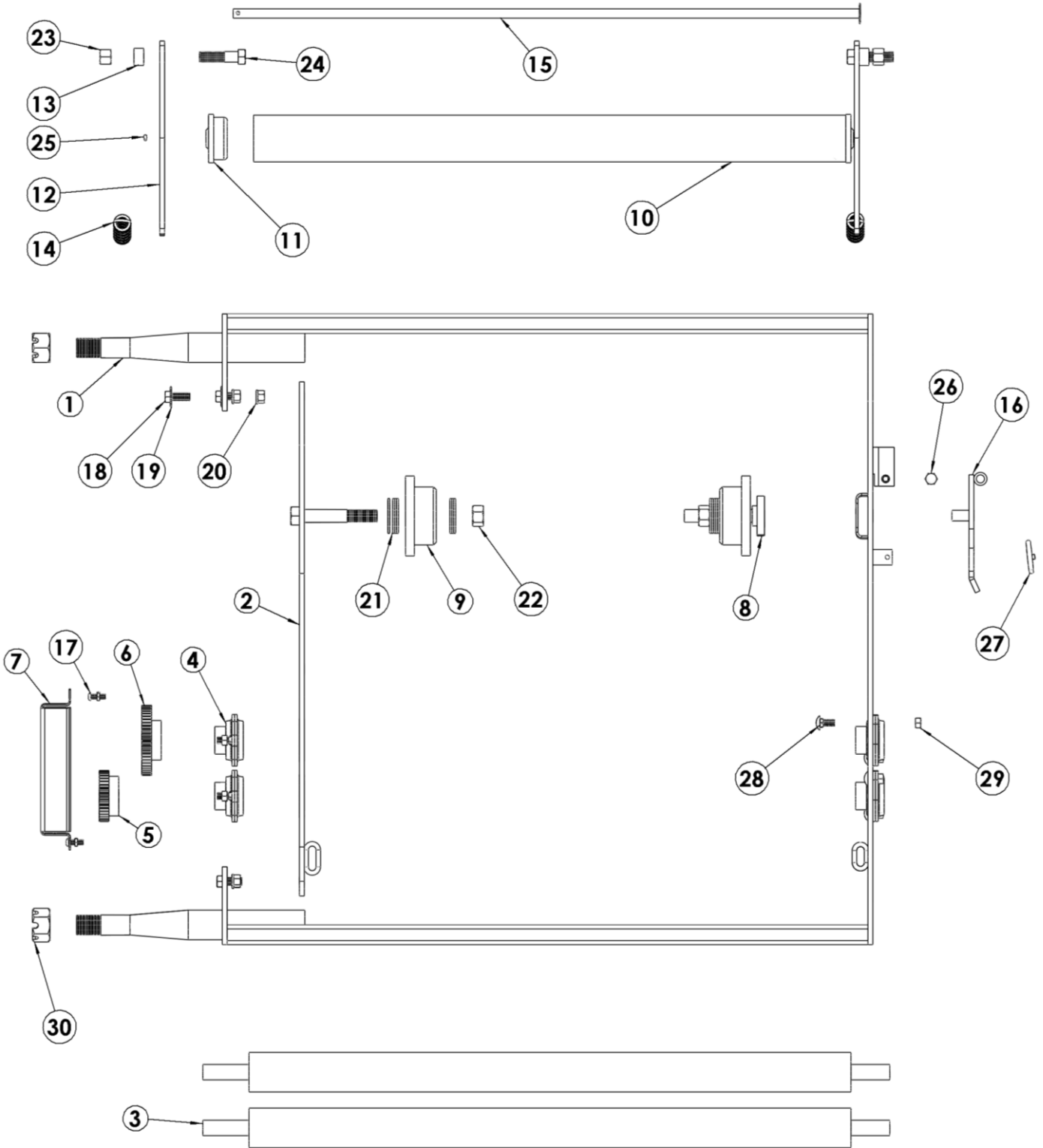

TL 5500AX2 Plastic Wrap Carrier

Item	Qty	Part #	Description
1A	2	TL550-100-072	Complete Wrap Carrier
1	2	TL550-100-089	Main Wrap Bracket
2	2	TL550-200-090	Main Wrap Side Insert
3	4	TL550-100-006	Tensioner Rollers
4	4	TL550-100-007	$\frac{3}{4}$ Bearing c/w Flange
5	2	TL550-100-008	Small Gear
6	2	TL550-100-009	Large Gear
7	2	TL550-100-010	Gear Cover
8A		TL5X2-500-103	Spool Holder c/w Parts (Ref # 8,9,21,22)
8	2	TL550-200-115	Spool Holder
9	4	TL550-200-012	Plastic Wrap Spool
10A	2	TL5X2-500-104	Slave Roller c/w End cap (Ref # 10,11)
10	2	TL550-100-022	ABS Pipe
11	4	TL500-100-021	HMWPVC Plastic End Cap
12	4	TL550-100-016	Slave Roller Mount Bracket
13	4	TL550-100-017	Spacer
14	4	TL500-100-135	Tensioner Spring
15	2	TL550-100-018	Slave Roller Axle Shaft
16	2	TL550-200-103	Spool Latch
17	8	Obtain Locally	10-24 x 3/4 Bolt c/w nut & Lockwasher
18	8	Obtain Locally	3/8-16 x 1 Bolt Gr.5
19	8	Obtain Locally	3/8 Flatwasher
20	10	Obtain Locally	3/8-16 Locknut
21	20	Obtain Locally	5/8 Flatwasher
22	4	Obtain Locally	5/8-11 Locknut
23	4	Obtain Locally	1/2-13 Locknut
24	4	Obtain Locally	1/2-13 x 2 Bolt Gr.5
25	2	Obtain Locally	1/8 Cotter Pin
26	2	Obtain Locally	3/8-16 x 2 1/2 Bolt Gr.5
27	2	Obtain Locally	3/16 Linch Pin
28	16	Obtain Locally	5/16-18 x 3/4 Carr Bolt
29	16	Obtain Locally	5/16-18 Locknut
30	4	Obtain Locally	1"-14 UNF Slotted Nut

TL 5500AX2 Hoop Brace

Prior to Serial # 12025

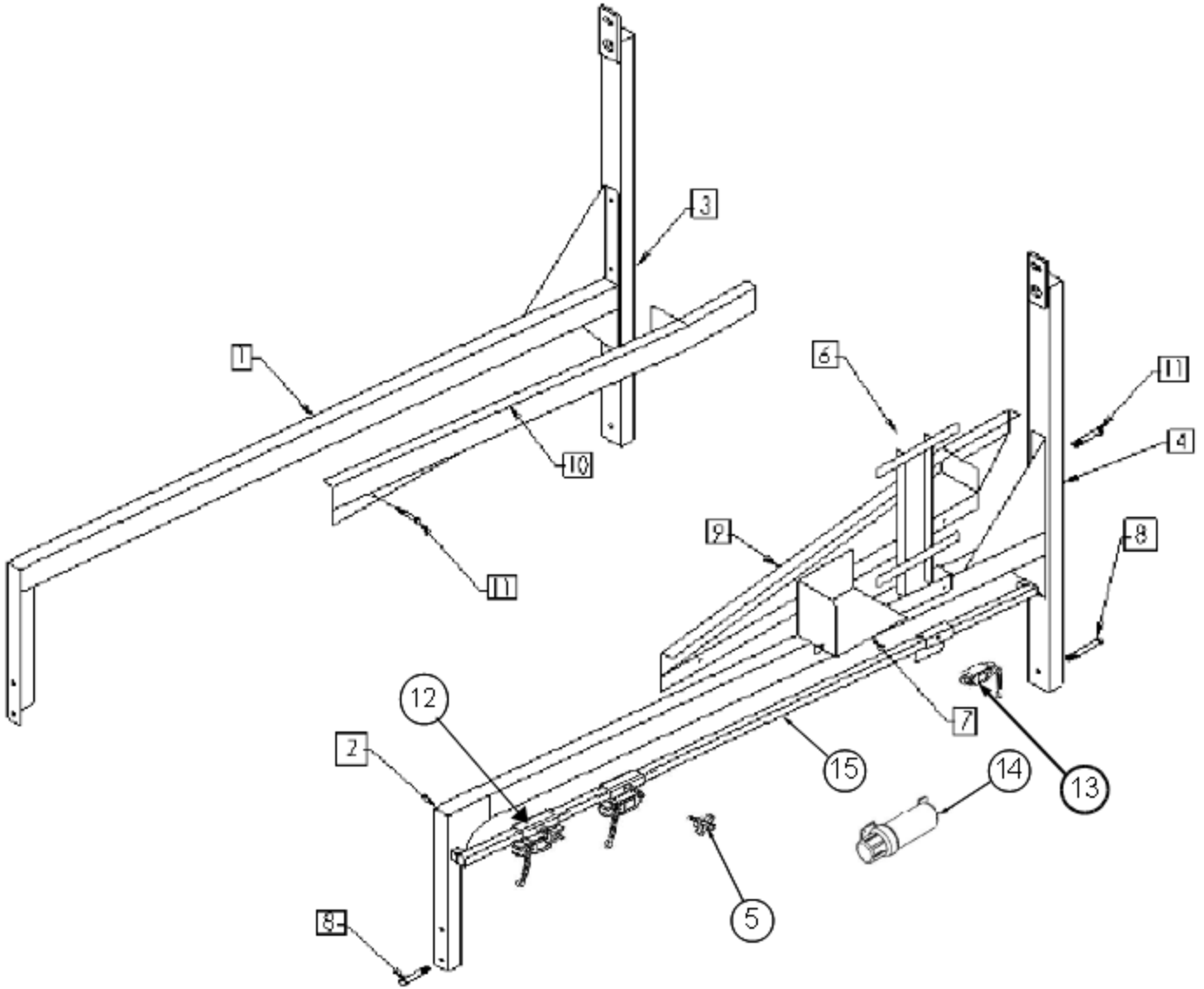

TL 5500AX2 Hoop Brace

Prior to Serial # 12025

Item	Qty	Part #	Description
1	1	TL5X2-100-100	Right Brace
2	1	TL5X2-100-101	Left Brace
3	1	TL5X2-100-102	Right Hoop Post
4	1	TL5X2-100-103	Left Hoop Post
5	3	TL5X2-100-104	Switch Adjuster Screw
6	1	TL5X2-100-105	Control Panel Mount
7	1	TL5X2-100-106	Mount
8	6	Obtain Locally	HB 1/2" X 3" HEX BOLT
9	1	TL5X2-100-110	Left Bale Deflector
10	1	TL5X2-100-111	Right Bale Deflector
11	6	Obtain Locally	HB 3/8" X 3 " Hex Bolt
12A		TL5X2-500-109	Switch Slider c/w Switch (Ref # 5,12,& 13)
12	3	TL5X2-100-242	Switch Slider
13	3	TL550-100-060	Limit Switch
14	1	TL5X2-201-111	Manual Holder
15	1	TL5X2-500-110	Switch Slider Tube

TL 5500AX2 Hoop Brace

Serial # 12026 to current

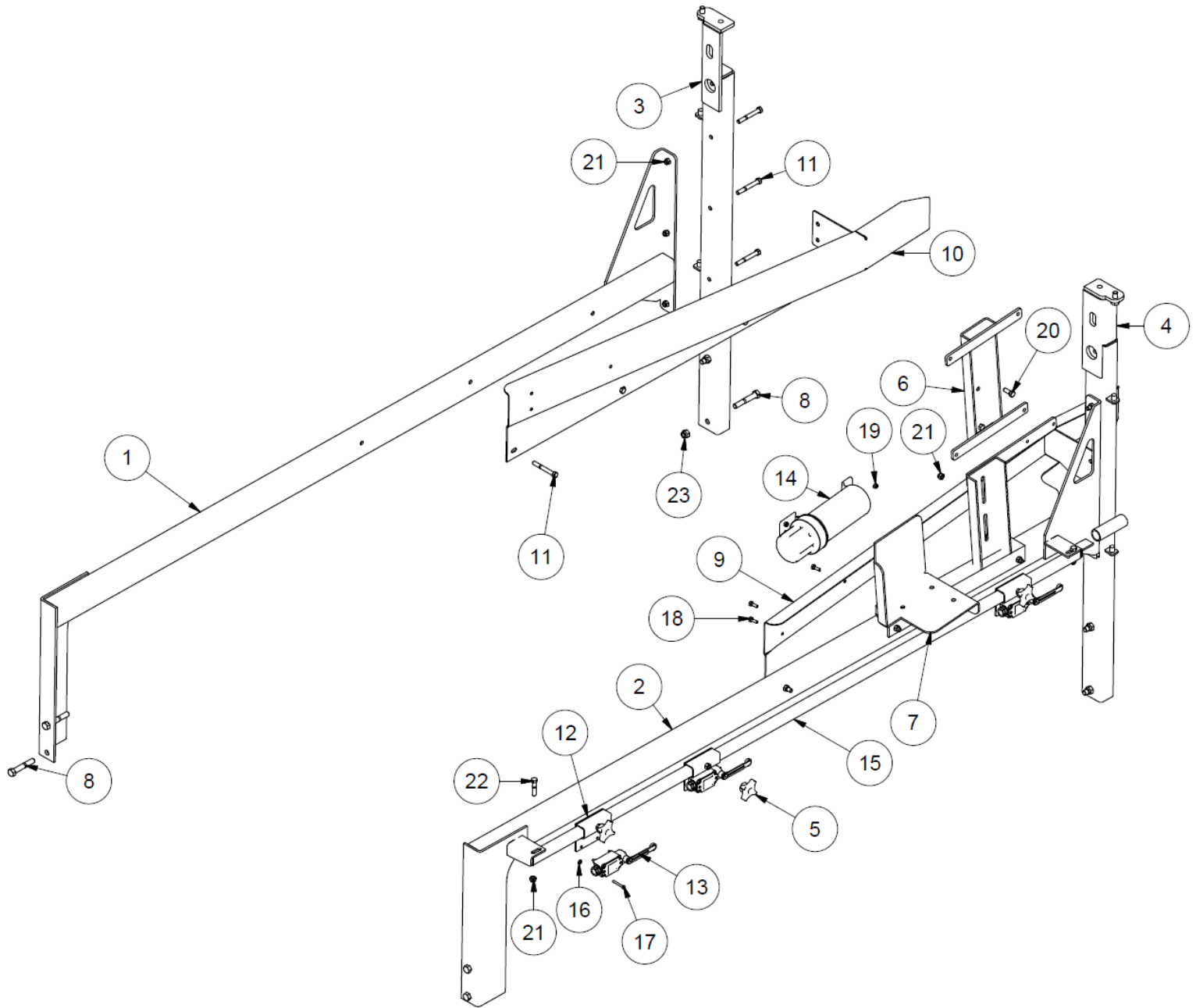

TL 5500AX2 Hoop Brace

Serial # 12026 to current

Item	Qty	Part #	Description
1	1	TL5X2-100-100	Right Brace
2	1	TL5X2-100-101	Left Brace
3	1	TL5X2-100-102	Right Hoop Post
4	1	TL5X2-100-103	Left Hoop Post
5	3	TL5X2-100-104	Switch Adjuster Screw
6	1	TL5X2-100-105	Control Panel Mount
7	1	TL5X2-100-106	Mount
8	8	Obtain Locally	HB 1/2 X 3 Hex Bolt
9	1	TL5X2-100-110	Left Bale Deflector
10	1	TL5X2-100-111	Right Bale Deflector
11	10	Obtain Locally	HB 3/8 X 3 Hex Bolt
12A		TL5X2-500-109	Switch Slider c/w Switch (Ref # 5,12 & 13)
12	3	TL5X2-100-242	Switch Slider
13	3	TL550-100-060	Limit Switch
14	1	TL5X2-201-111	Manual Holder
15	1	TL5X2-500-110	Switch Slider Tube
16	12	Obtain Locally	HN 10-24 Hex Nut
17	12	Obtain Locally	MS 10-24 X 1 3/4 Machine Screw
18	3	Obtain Locally	HB 1/4 X 3/4 Hex Bolt
19	3	Obtain Locally	HN 1/4 Hex Nut
20	2	Obtain Locally	HB 3/8 X 1 Hex Bolt
21	14	Obtain Locally	HN 3/8 Hex Nut
22	2	Obtain Locally	HB 3/8 X 1 3/4 Hex Bolt
23	8	Obtain Locally	HN 1/2 Hex Nut

TL 5500AX2 Safety Guard

Prior to Serial # 12025

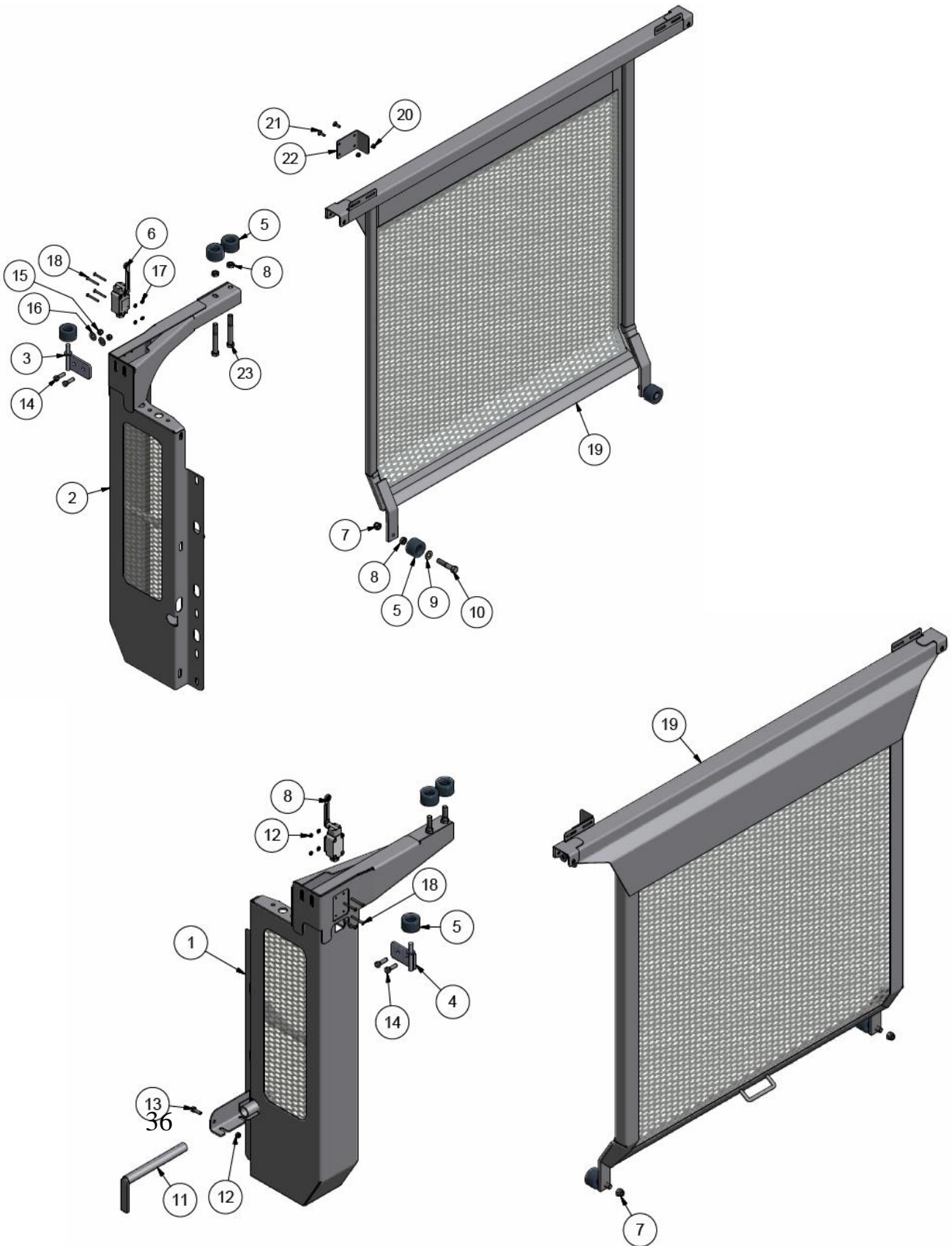

TL 5500AX2 Safety Guard

Prior to Serial # 12025

Item	Qty	Part #	Description
1	1	TL5X2-100-025	Left Safety Guard
2	1	TL5X2-100-024	Right Safety Guard
3	1	TL5X2-301-103	Right Top Door Roller Bracket
4	1	TL5X2-301-120	Left Top Door Roller Bracket
5	6	TL5X2-301-121	Door Roller
6	2	TL550-100-060	Limit Switch
7	6	Obtain Locally	1/2-13 Locknut
8	8	Obtain Locally	1/2-13 Jam Nut
9	4	Obtain Locally	1/2 SAE Flatwasher
10	4	Obtain Locally	1/2-13 x 2 1/2 Bolt Gr.5
11	1	TL550-200-050	Hoop Lock Pin
12	1	Obtain Locally	5/16-18 Locknut
13	1	Obtain Locally	5/16-18 x 1 Bolt Gr.5
14	4	Obtain Locally	3/8-16 x 1 1/4 Bolt Gr.5
15	4	Obtain Locally	3/8-16 Locknut
16	4	Obtain Locally	3/8 Flatwasher
17	8	Obtain Locally	10-24 Nut
18	8	Obtain Locally	10-24 x 1 3/4 Bolt Gr.5
19	2	24111	Door Weldment
20	4	Obtain Locally	1/4 Lock Nut
21	4	Obtain Locally	1/4 x 3/4 Carriage Bolt
22	2	25062	Door Switch Tab
23	4	Obtain Locally	1/2-13 x 4 Bolt

TL 5500AX2 Safety Guard

Serial # 12026 to current

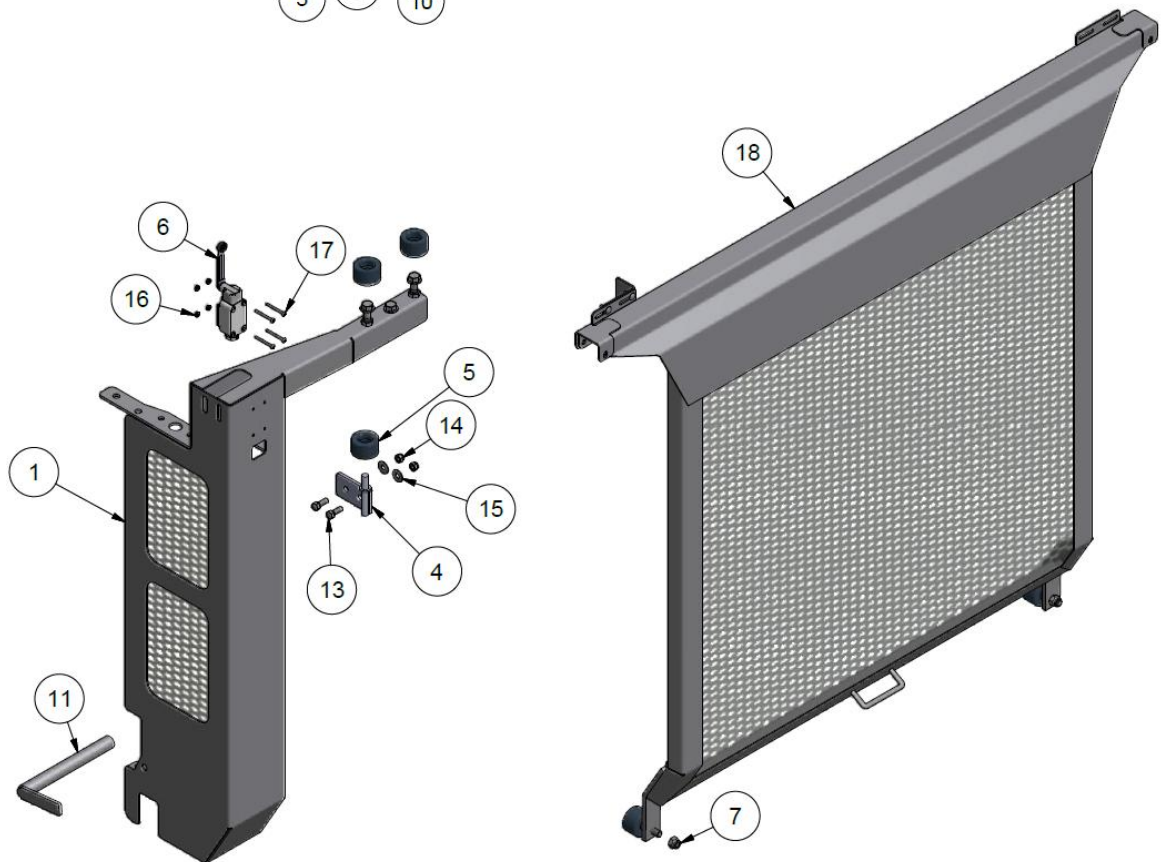
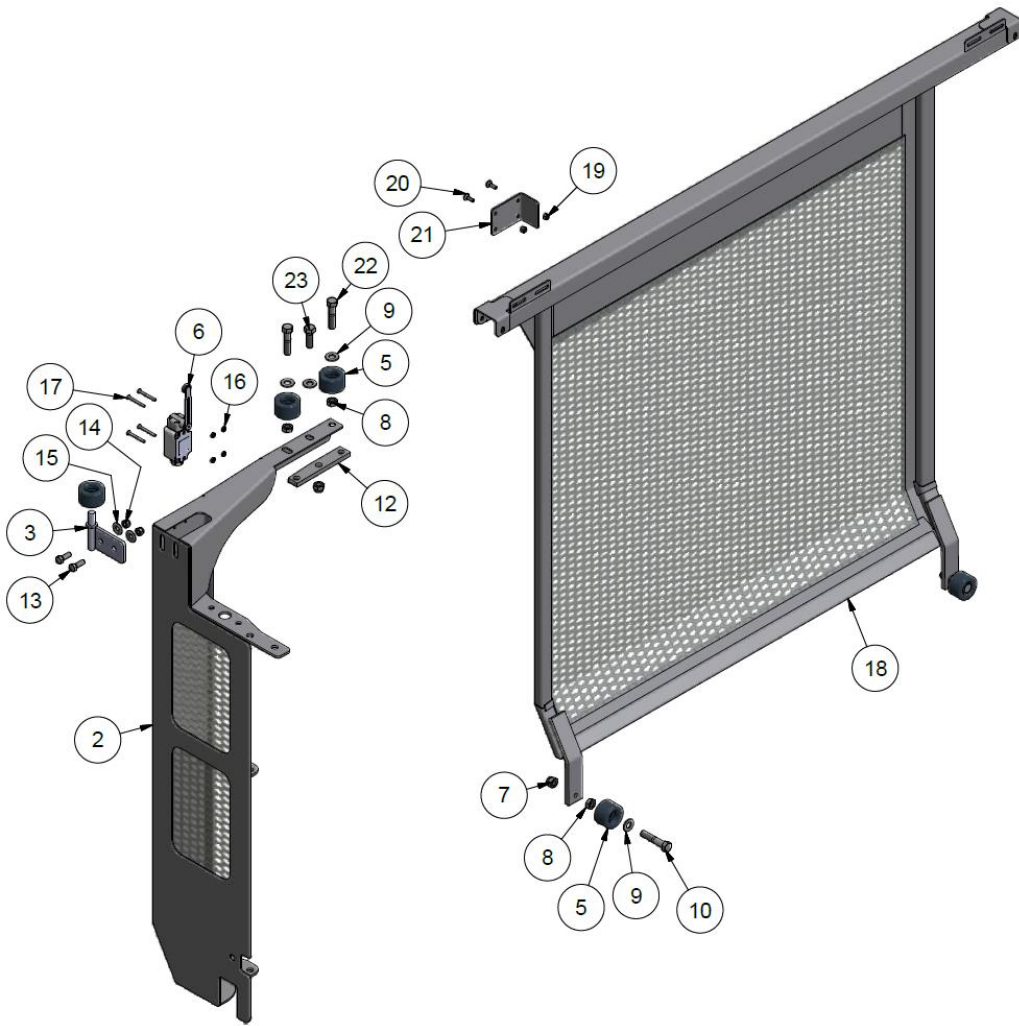

TL 5500AX2 Safety Guard

Serial # 12026 to current

Item	Qty	Part #	Description
1	1	TL109-100-364	Left Safety Guard
2	1	TL109-100-363	Right Safety Guard
3	1	TL5X2-301-103	Right Top Door Roller Bracket
4	1	TL5X2-301-120	Left Top Door Roller Bracket
5	10	TL5X2-301-121	Door Roller
6	2	TL550-100-060	Limit Switch
7	6	Obtain Locally	1/2-13 Locknut
8	8	Obtain Locally	1/2-13 Jam Nut
9	10	Obtain Locally	1/2 SAE Flatwasher
10	4	Obtain Locally	1/2-13 x 2 1/2 Bolt Gr.5
11	1	TL550-200-050	Hoop Lock Pin
12	2	28741	Rear Roller Mount
13	4	Obtain Locally	3/8-16 x 1 1/4 Bolt Gr.5
14	4	Obtain Locally	3/8-16 Locknut
15	4	Obtain Locally	3/8 Flatwasher
16	8	Obtain Locally	10-24 Nut
17	8	Obtain Locally	10-24 x 1 3/4 Bolt Gr.5
18	2	24111	Door Weldment
19	4	Obtain Locally	1/4 Lock Nut
20	4	Obtain Locally	1/4 x 3/4 Carriage Bolt
21	2	25062	Door Switch Tab
22	4	Obtain Locally	1/2 x 2 1/4 Bolt
23	2	Obtain Locally	1/2 x 1 1/2 Bolt

TL 550AX2 Cylinder Support

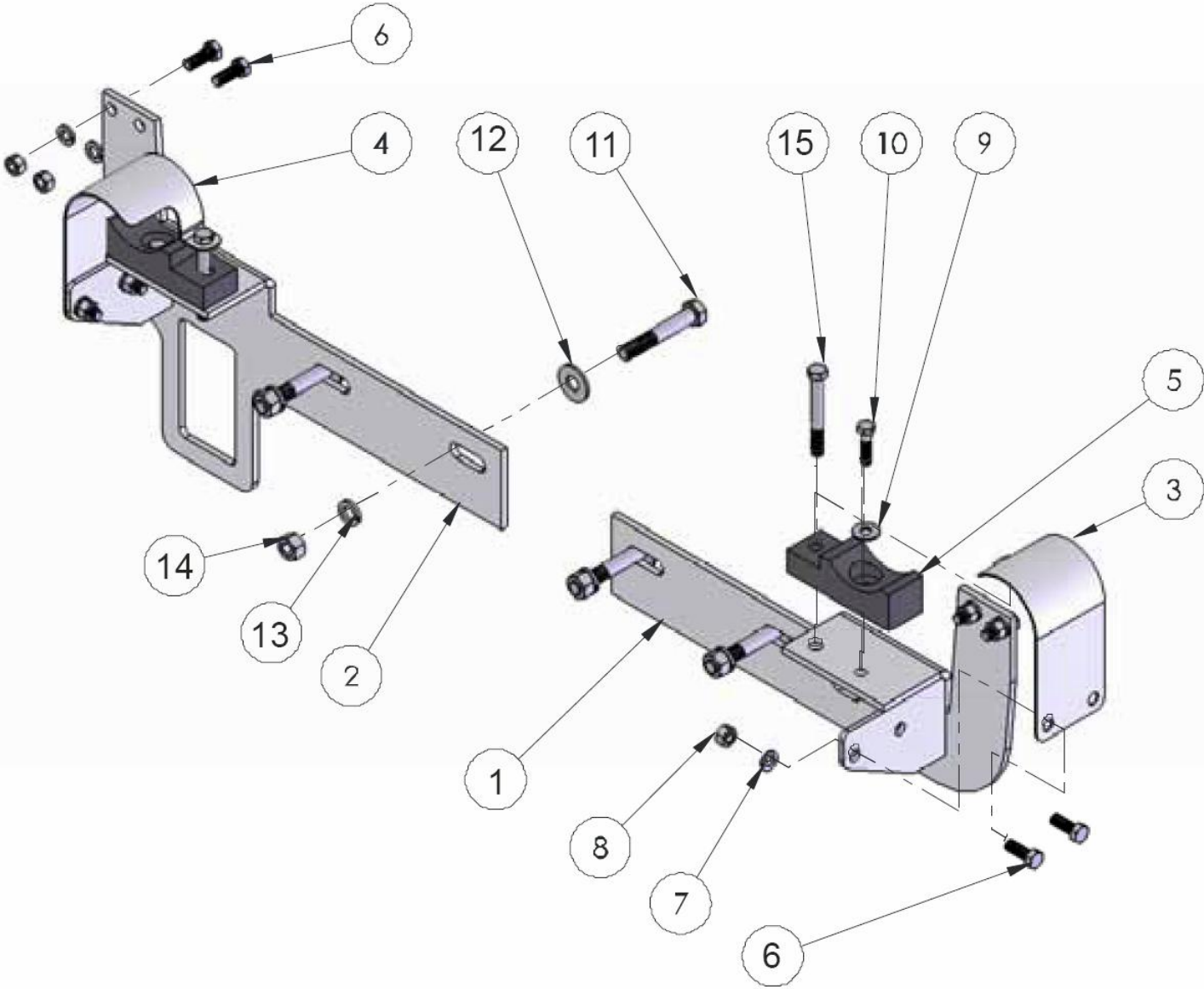

TL 5500AX2 Cylinder Support

Item	Qty	Part #	Description
1	1	TL5X2-301-130	Right Support Bracket
2	1	TL5X2-301-131	Left Support Bracket
3	1	TL5X2-100-132	Right Cylinder Clamp
4	1	TL5X2-100-133	Left Cylinder Clamp
5	2	TL550-200-109	Cylinder Support
6	8	Obtain Locally	3/8 x 1 Bolt
7	8	Obtain Locally	3/8 Lockwasher
8	8	Obtain Locally	3/8 Nut
9	2	Obtain Locally	5/16 Flatwasher
10	2	Obtain Locally	5/16 x 1 1/4 Bolt
11	4	Obtain Locally	1/2 x 3 Bolt
12	4	Obtain Locally	1/2 Flatwasher
13	4	Obtain Locally	1/2 Lockwasher
14	4	Obtain Locally	1/2 Nut
15	2	Obtain Locally	3/8 x 3 Bolt

TL 5500AX2 Hoop Drive

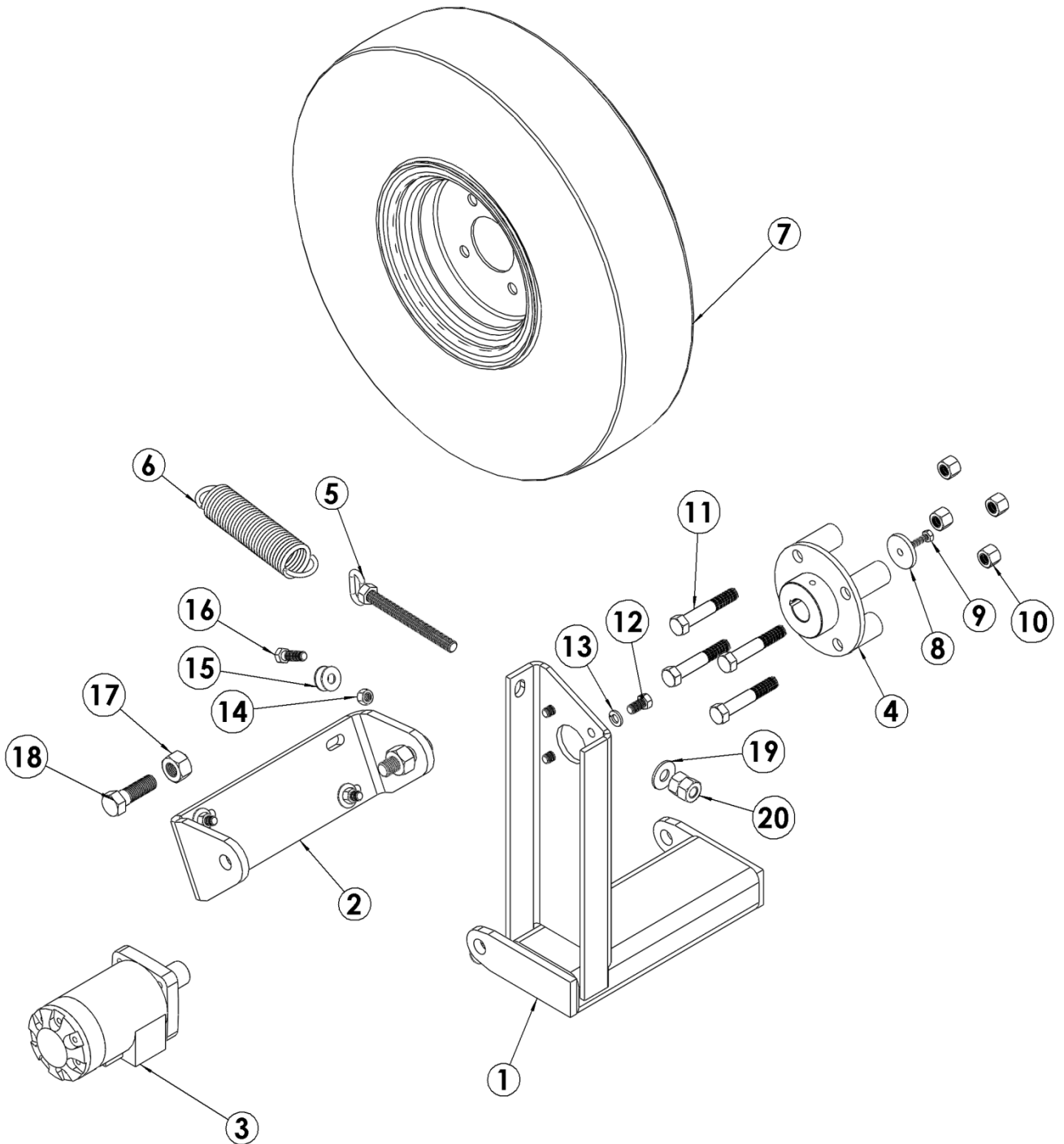

TL 5000AX2 Hoop Drive

Item	Qty	Part #	Description
1	1	TL5X2-100-049	Drive Base
2	1	TL5X2-100-090	Drive Base Mount
3	1	TL5X2-200-050	Hydraulic Motor (M & S)
4	1	TL500-100-051	Wheel Hub
5	1	TL500-101-232	Spring Tension Bolt
6	1	TL500-101-231	Tension Spring
7	1	TL500-100-052	Hoop Drive Wheel
8	1	TL500-100-060	Wheel Hub Washer
9	1	Obtain Locally	1/4-20 x 1 Bolt Gr.5
10	4	TL500-100-054	Wheel Nuts
11	4	Obtain Locally	1/2-20 x 3 UNF Bolt Gr.5
12	4	Obtain Locally	3/8-16 x 1 Bolt Gr.5
13	4	Obtain Locally	3/8 Lockwasher
14	4	Obtain Locally	3/8-16 Locknut
15	8	Obtain Locally	3/8 Flatwasher
16	4	Obtain Locally	3/8-16 x 1 1/4 Bolt Gr.5
17	2	Obtain Locally	5/8-11 Locknut
18	2	Obtain Locally	5/8-11 x 2 Bolt Gr.5
19	1	Obtain Locally	1/2 Flatwasher
20	2	Obtain Locally	1/2-13 Nut

TL 550AX2 Axle/ Spindle/ Hub

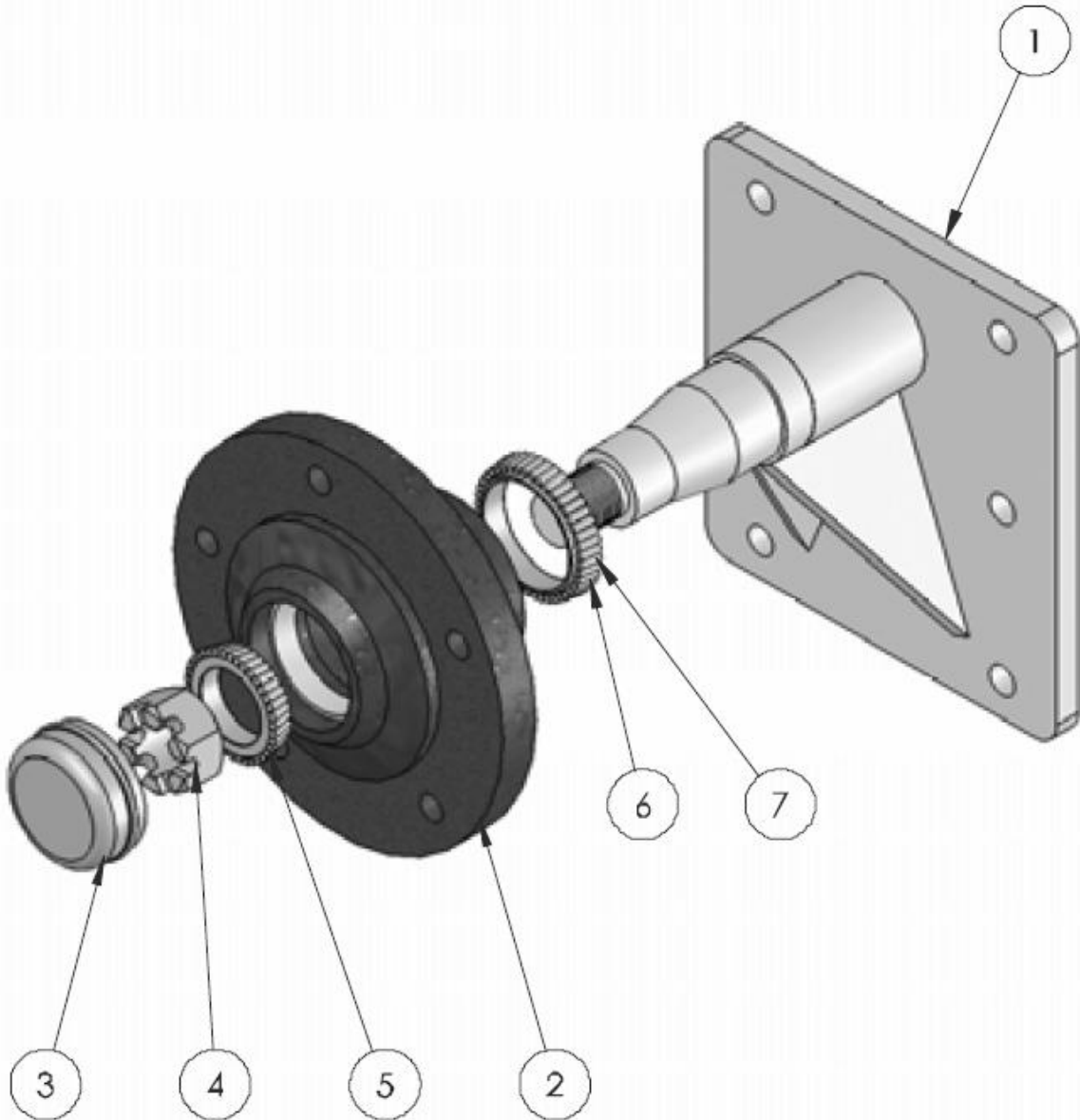

TL 5500AX2
Axle/ Spindle/ Hub

Item	Qty	Part #	Description
1	1	TL550-200-001	Spindle
2	1	TL500-100-066	Hub
3	1	TL500-100-073	Dust Cap
4	1	TL500-100-070	Castellated Nut
5	1	TL500-100-068	Outer Bearing
6	1	TL500-100-064	Inner Bearing
7	1	TL500-100-063	Inner Seal

★ 4 complete hubs per machine

TL 5500AX2 Front Steering

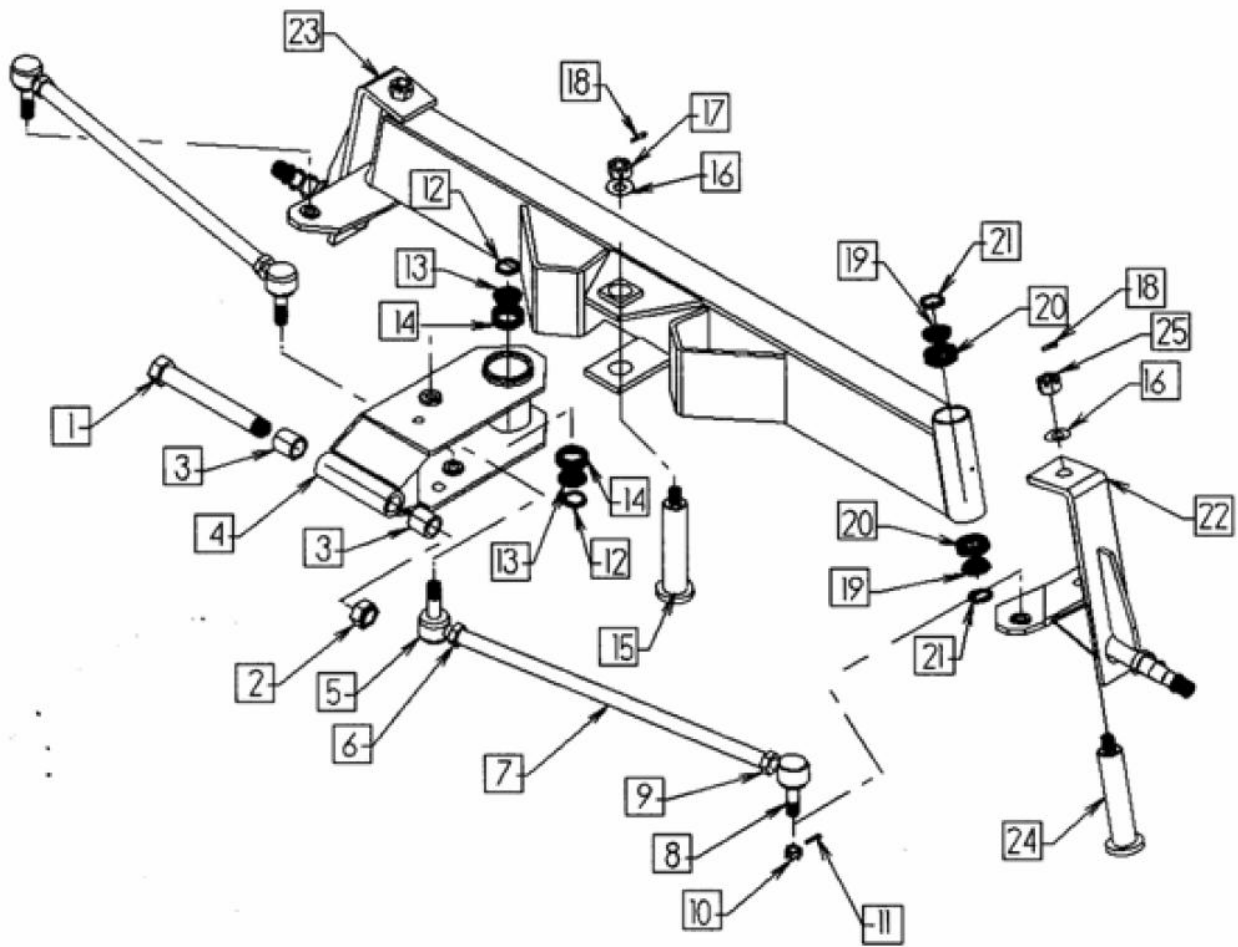

**TL 5500AX2
Front Steering**

Item	Qty	Part #	Description
1	1	TL500-100-152	7/8 x 1 Bolt
2	1	TL500-100-153	7/8 Locknut
3	2	TL550-111-012	Tongue Bracket Bushing
4	1	TL550-221-008	Tongue Bracket Asm
5	2	TL550-111-006	Tie Rod End Right Thread
6	2	TL550-111-003	¾ Jam Nut (NF RH)
7	2	TL550-220-001	Tie Rod
8	2	TL550-111-007	Tie Rod End Left Thread
9	2	TL550-111-002	¾ Jam nut (NF LH)
10	4	TL550-111-004	9/16 NF Slotted Hex Nut
11	4	TL550-111-005	1/8 Cotter Pin
12	2	TL550-111-011	Tongue Bracket Seal
13	2	TL550-111-010	Tongue Bracket Timkin Bearing
14	2	TL550-111-009	Tongue Bracket Timkin Cup
15	1	TL550-221-013	Tongue Bracket Pin
16	3	TL550-111-014	13/16 Flatwasher
17		TL550-111-015	Tongue Bracket Nut
18		TL550-111-016	3/16 x 2 Cotter Pin
19		TL550-200-080	Spindle Bearing Timkin Cone
20		TL550-200-081	Spindle Bearing Timkin Cup
21		TL550-200-082	Spindle Bearing Seal
22		TL550-100-083	Left Side Spindle Assy
23		TL550-100-084	Right Side Spindle Assy
24		TL550-100-085	Spindle Pin
25	2	25578	3/4" Fine Thread Castle Nut

TL 5500AX2 Brake

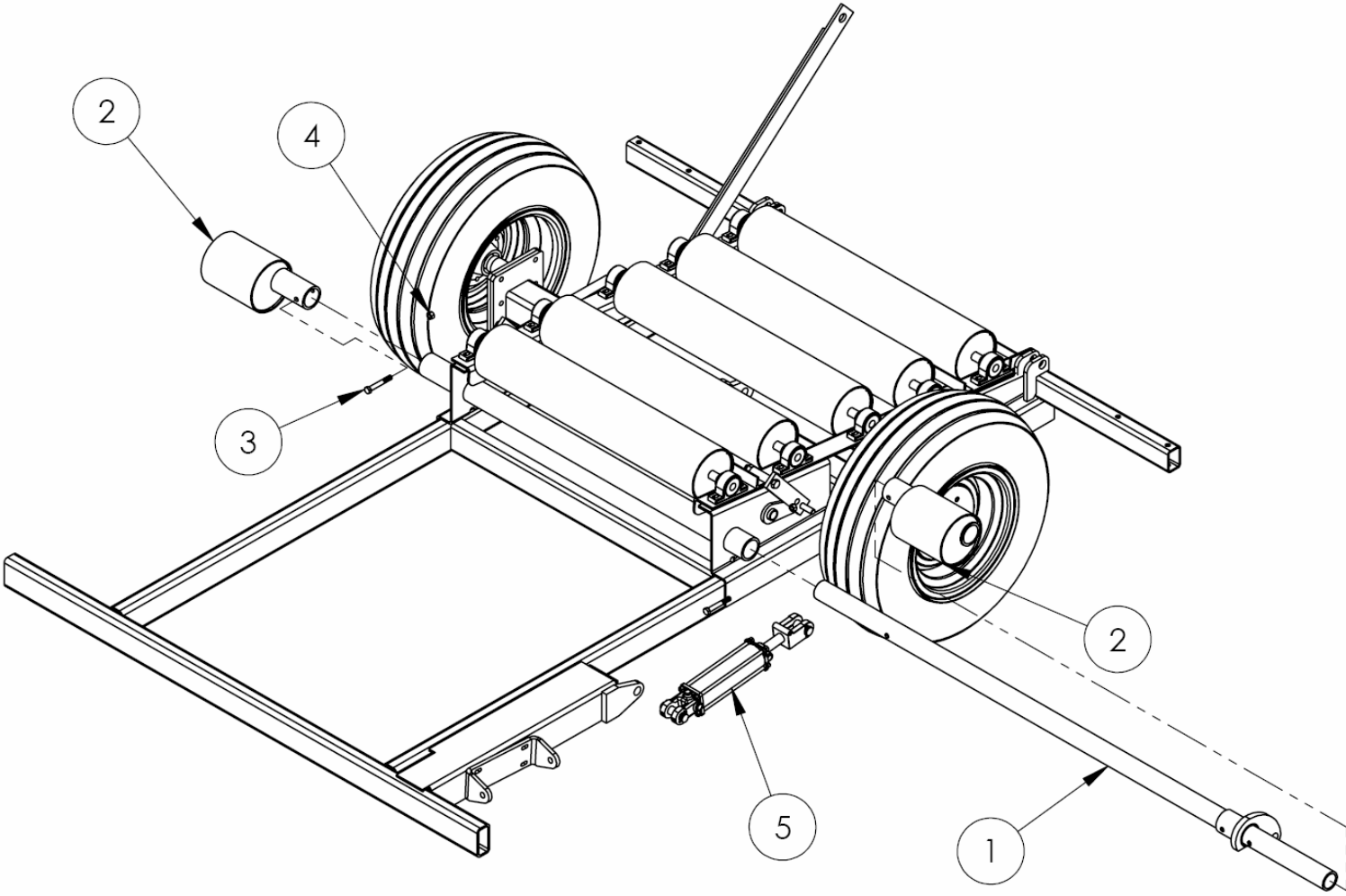

TL 5500AX2 Brake

Item #	Qty	Part #	Description
1	1	TL5X2-100-028	Rocker Tube
2	1	TL550-100-029	Brake Eccentric
3	1	Obtain Locally	½ x 3 1/2
4	1	Obtain Locally	½ Locknut
5	1	TL500-100-082	Hydraulic Cylinder

TL 5500AX2 Rear Roller

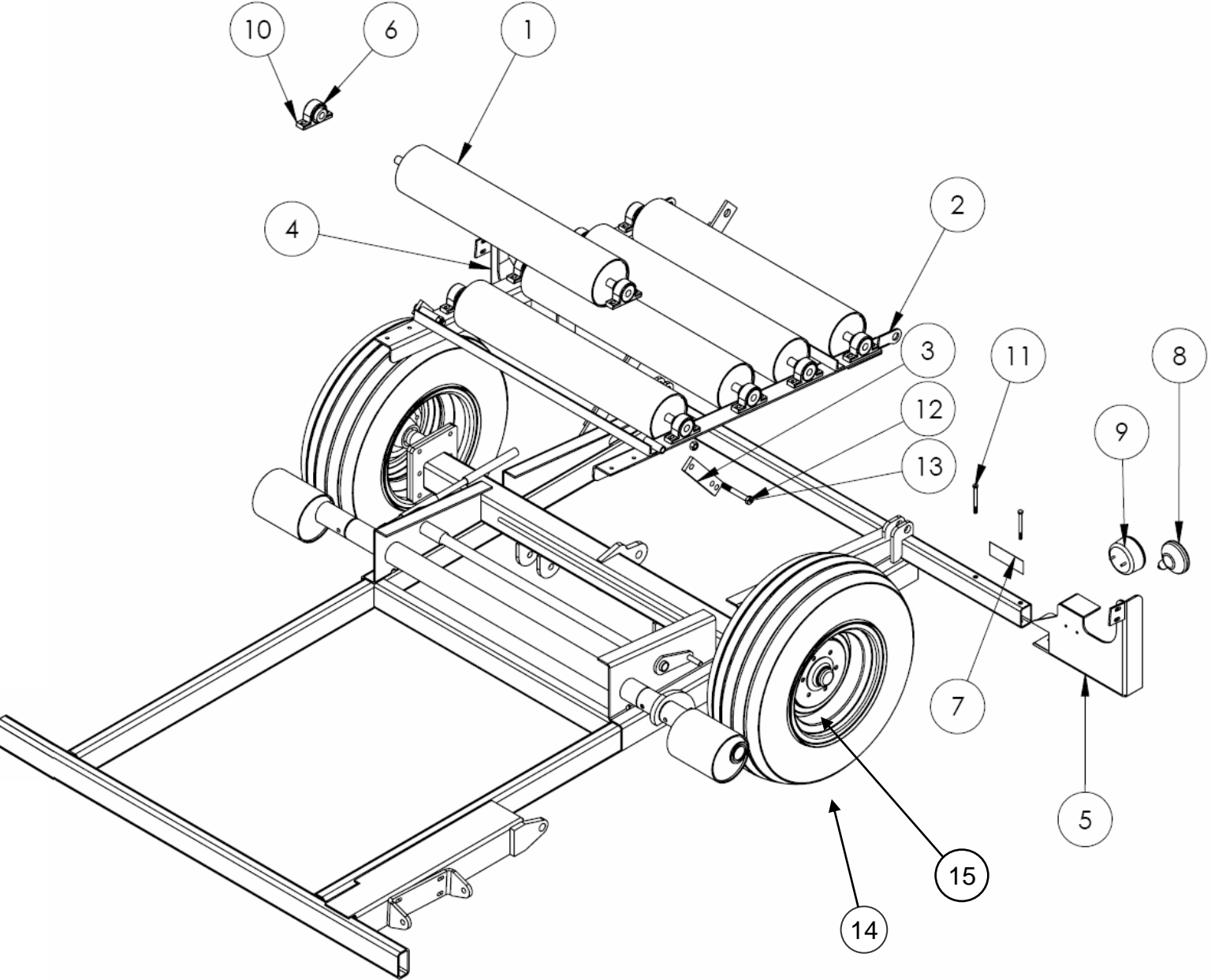

TL 5500AX2 Rear Roller

Item #	Qty	Description	Part #
1	5	TL500-100-086	Large Roller
2	1	TL5X2-301-007	Riser Frame
3	1	TL5X2-301-030	Riser Link
4	1	TL5X2-100-031	Right Rear Light Bkt
5	1	TL5X2-100-032	Left Rear Light Bkt
6	10	TL5X2-100-030	1" Bearing
7	2	TL5X2-100-033	Red Reflector
8	2	TL5X2-100-034	Amber Light
9	2	TL5X2-100-035	Red Light
10	20	Obtain Locally	3/8 x 1 1/2 Bolt
11	4	Obtain Locally	3/8 x 4 Bolt
12	1	Obtain Locally	5/8 x 4 Bolt
13	2	Obtain Locally	5/8 Locknut
14	2	WHE TI11-15-8	Galaxy Tire 11L-15
15	12	TL500-100-072	Wheel Bolt 9/16 x 1 3/4

TL 5500AX2 Tail

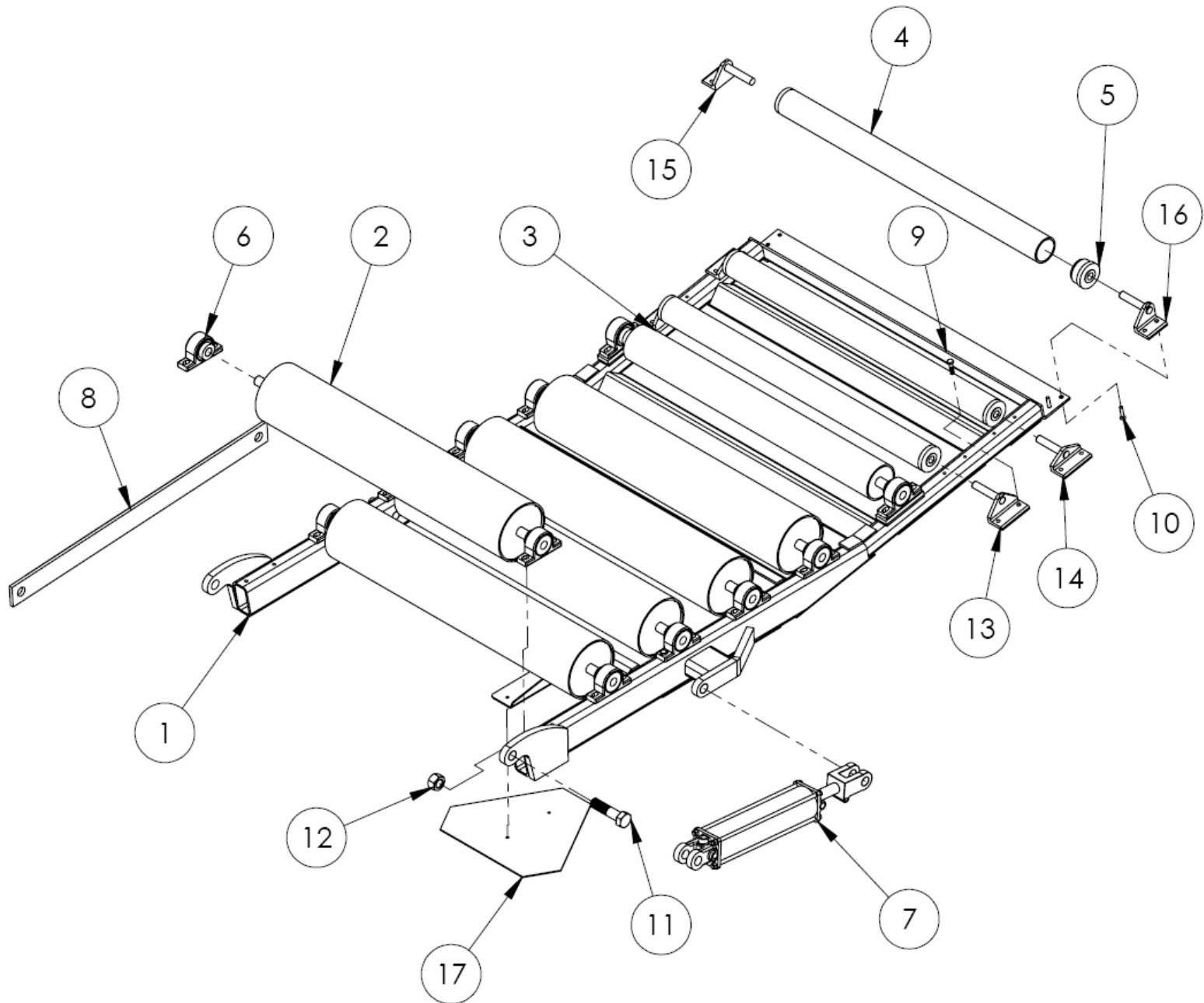

TL 5500AX2 Tail

Item #	Qty	Part #	Description
1	1	TL550-100-033	Tail Base
2	5	TL500-100-086	Large Roller
3	1	TL500-100-099	4" Roller
4	3	TL550-200-106	2 7/8 Roller
5	6	TL550-100-092	3/4" Nylon Bearing
6	12	TL550-100-030	1" Bearing
7	1	TL550-100-107	3 x 12 Cylinder
8	1	TL599-100-035	Tail Tie Bar
9	8	Obtain Locally	3/8 x 1 1/2 Bolt
10	4	Obtain Locally	5/16 x 1 1/2 Flathead
11	2	Obtain Locally	1 x 4 Bolt
12	2	Obtain Locally	1" Locknut
13	2	TL550-200-002	#1 Small Roller Bkt
14	2	TL550-200-003	#2 Small Roller Bkt
15	1	TL550-200-004	#3 RH Small Roller Bkt
16	1	TL550-200-005	#3 LH Small Roller Bkt
17	1	DESMV	SMV Sign

TL 5500AX2 Bale Saddle

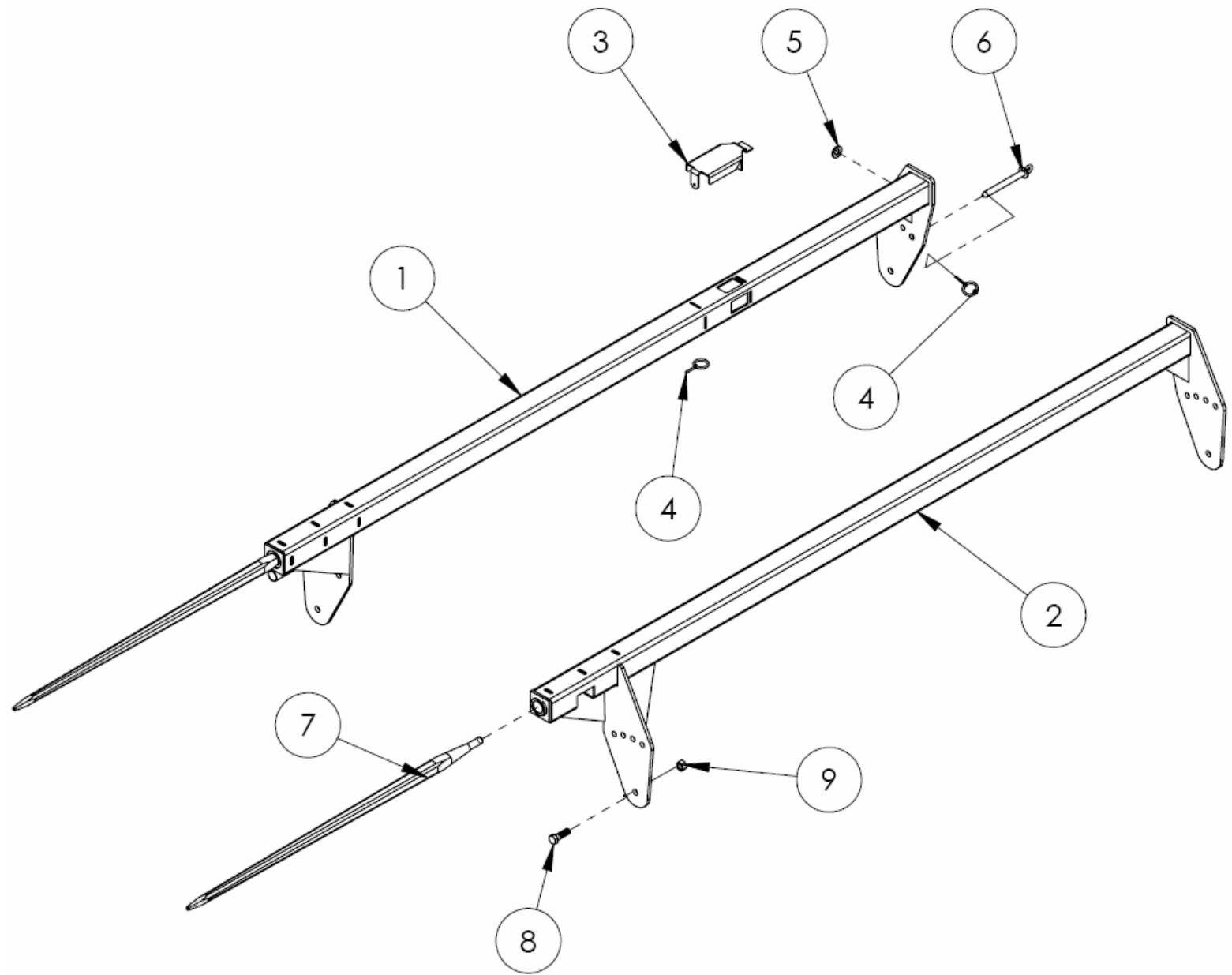

TL 5500AX2 Bale Saddle

Item	Qty	Part #	Description
1	1	TL5X2-301-140	Left Bale Guide
2	1	TL5X2-301-141	Right Bale Guide
3	1	TL5X2-301-142	Trigger Plate
4	5	TL550-200-108	3/16 Lynch Pin
5	1	TL5X2-100-143	Grommet
6	4	TL550-200-104	½ Pin
7	2	TL5X2-301-144	Bale Spear
8	2	Obtain Locally	5/8 x 2 Bolt
9	2	Obtain Locally	5/8 Locknut

TL 5500AX2 Ram

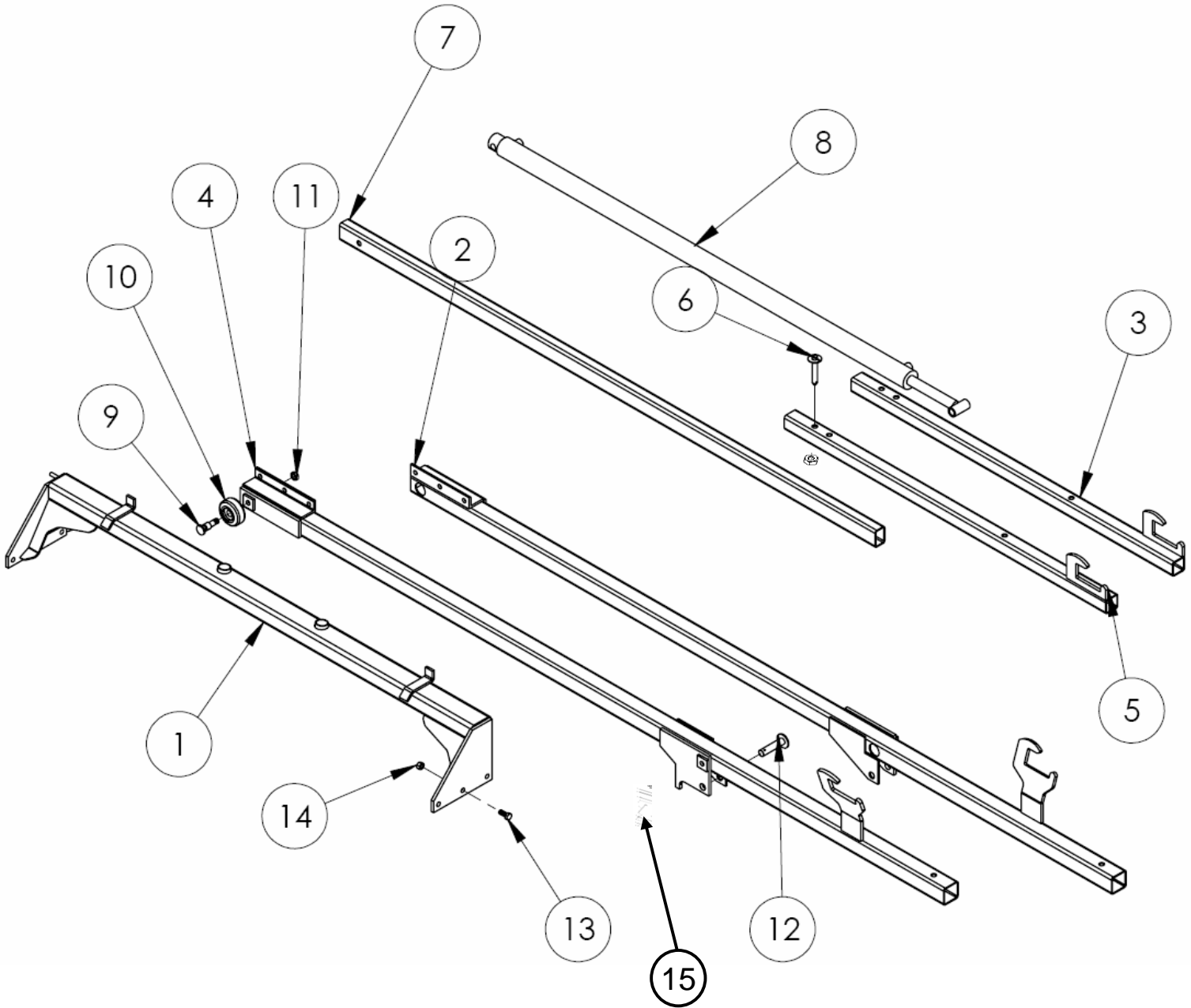

TL 5500AX2 Ram

Item	Qty	Part #	Description
1	1	TL5X2-301-150	Front Ram member
2	1	TL5X2-301-151	Right Ram Tube
3	1	TL5X2-301-152	Right Rear Extension
4	1	TL5X2-301-153	Left Ram Tube
5	1	TL5X2-301-154	Left Rear Extension
6	2	TL5X2-500-139	$\frac{3}{4}$ Drawbar Pin (comes with hairpin)
7	1	TL500-301-048	Pushoff Tube
8	2	TL550-100-043	Ram Cylinder
9	2	TL5X2-301-156	Ram Wheel Axle
10	2	TL5X2-301-157	Ram Wheel
11	2	Obtain Locally	$\frac{3}{4}$ UNF Jam Nut
12	4	TL550-100-042	Ram Cylinder Pin
13	6	Obtain Locally	5/8-18 x 2 UNF # 5 Bolt
14	6	Obtain Locally	5/8 UNF Nut
15	4	Obtain Locally	3/16 x 2 Cotter Pin
	2	TLSK25	Ram Cylinder Seal Kit

TL 550AX2 Side Rail

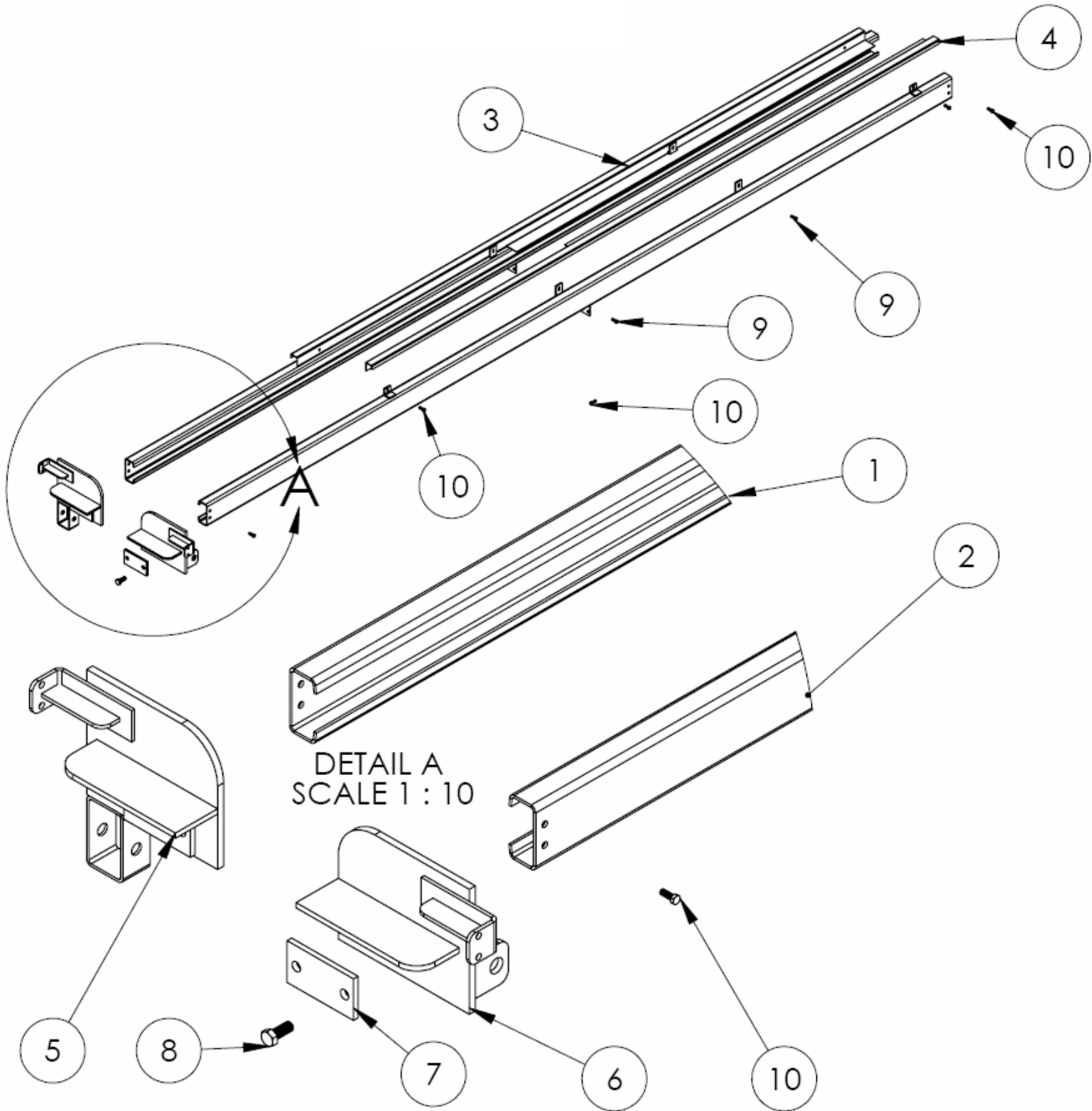

TL 5500AX2 Side Rail

Item #	Qty	Part #	Description
1	1	TL5X2-301-170	Right Side Rail
2	1	TL5X2-301-171	Left Side Rail
3	1	TL5X2-301-172	Right Guard/ Track
4	1	TL5X2-301-176	Left Guard/ Track
5	1	TL5X2-100-173	Right Front Cylinder Mount
6	1	TL5X2-100-174	Left Front Cylinder Mount
7	1	TL5X2-100-175	Reinforcing Plate
8	1	Obtain Locally	5/8 x 1 ½ UNF # 5 Bolt
9	3	Obtain Locally	5/16 x 1 Flathead Bolt
10		Obtain Locally	3/8 x 1 Bolt

TL 5500AX2 Front Push-off

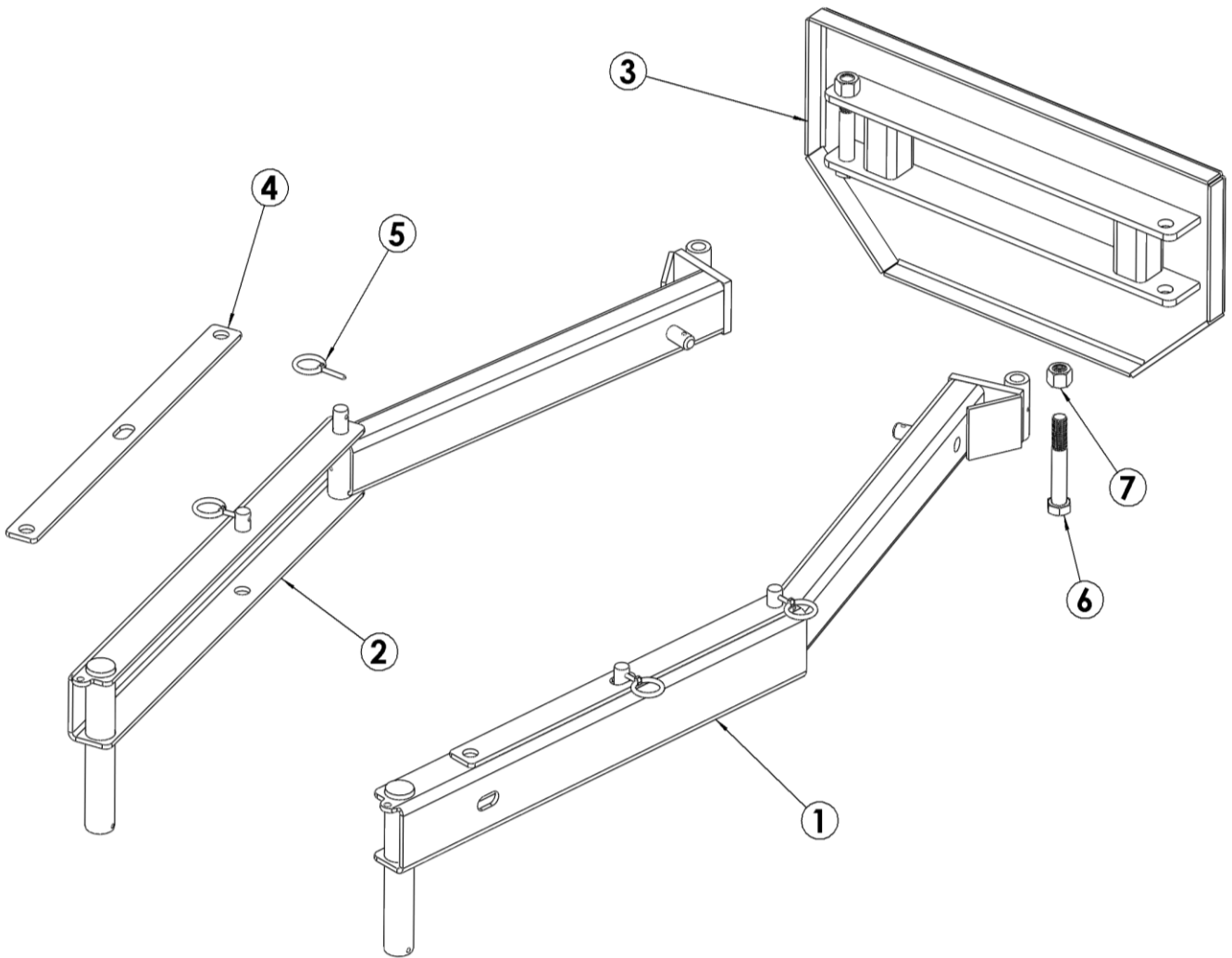

TL 5500AX2 Front Push-off

Item	Qty	Part #	Description
1	1	TL5X2-500-143	Left Front Pushoff Arm
2	1	T5X2-500-144	Right Front Pushoff Arm
3	1	TL5X2-301-016	Push Plate
4	2	TL599-100-017	X Brace
5	4	Obtain Locally	3/16 Linch Pin
6	2	Obtain Locally	3/4-10 x 5 1/2 Bolt Gr.5
7	2	Obtain Locally	3/4-10 Locknut

TL 5500AX2 Tongue

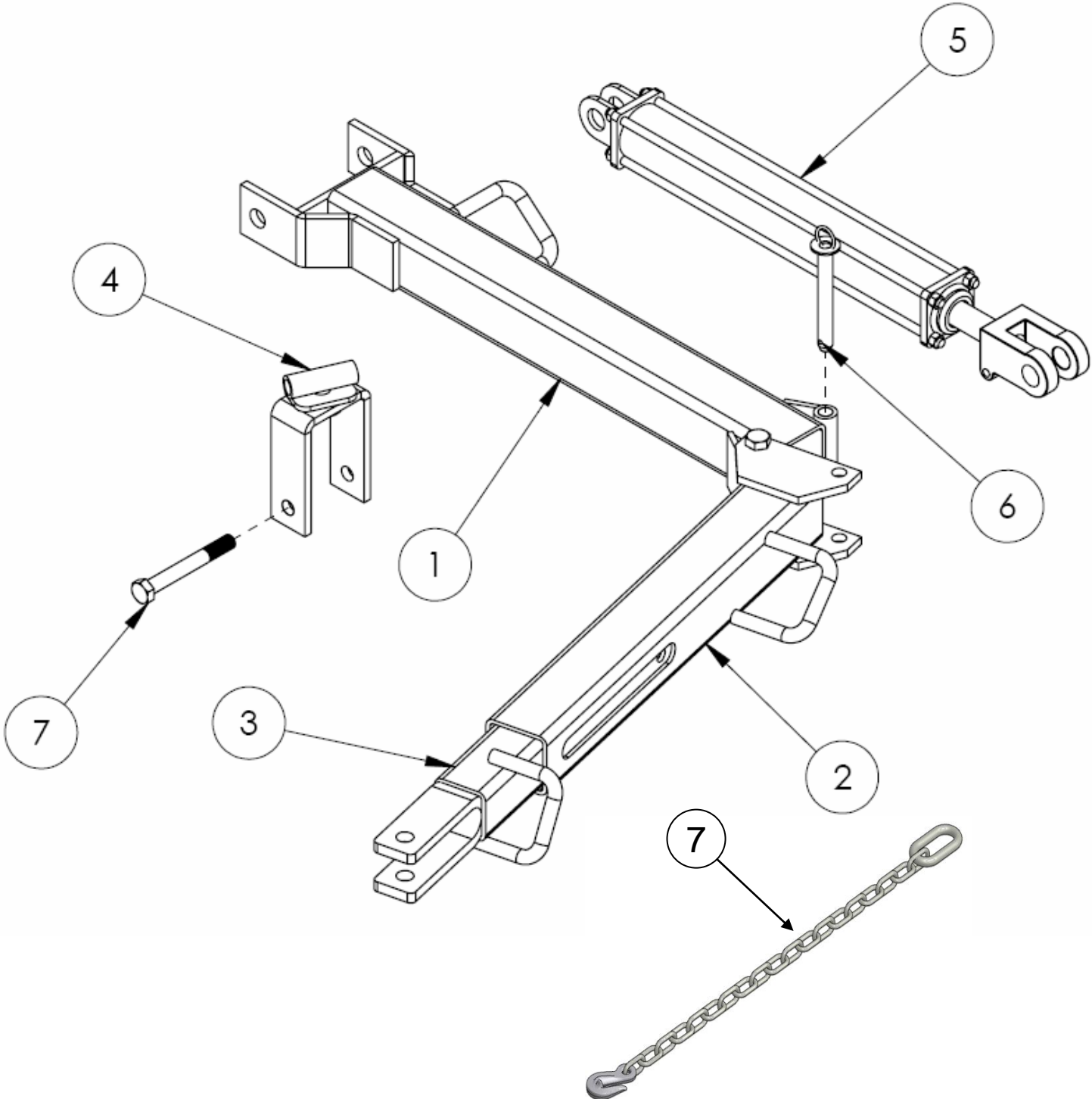

TL 5500AX2 Tongue

Item	Qty	Part #	Description
1	1	TL550-100-051	Main Tongue
2	1	TL550-100-052	Swinging Tongue
3	1	TL550-100-053	Sliding Tongue
4	1	TL500-301-160	Tongue Holder
5	1	TL500-100-103	2 x 16 Cylinder
6	1	TL500-100-154	Tongue Pin
7	1	25262	10,000 lbs Safety Chain
	1	TL109-100-354	Steering Cylinder Seal Kit

TL 5500AX2 Fender/ Engine Guard

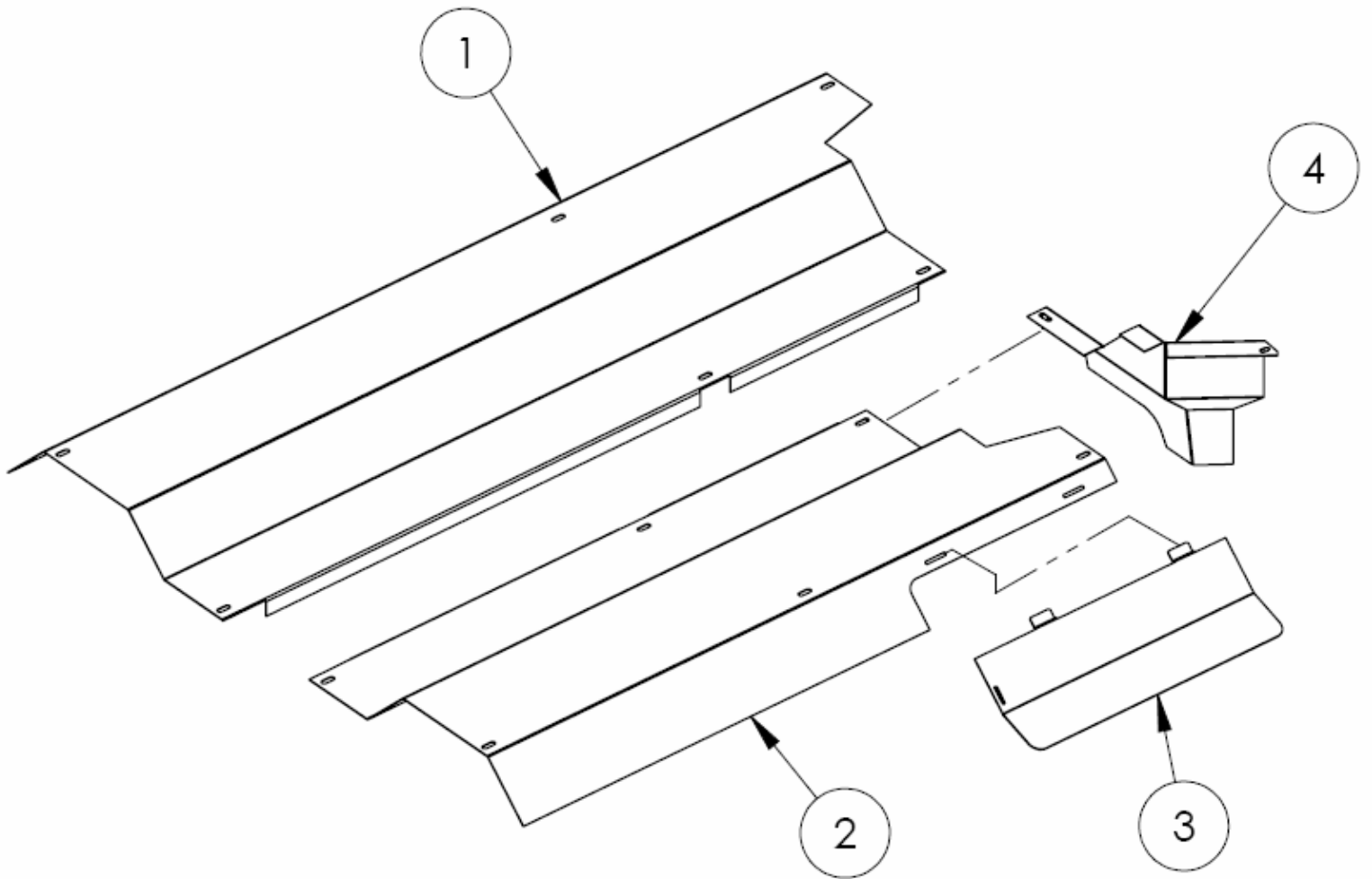

TL 5500AX2 Fender/ Engine Guard

Item #	Qty	Part #	Description
1	1	TL5X2-301-101	Right Fender
2	1	TL5X2-301-100	Left Fender
3	1	TL5X2-301-145	Rear Engine Shield
4	1	TL5X2-301-146	Engine Side Shield

TL 5500AX2 Hydraulic Oil Tank

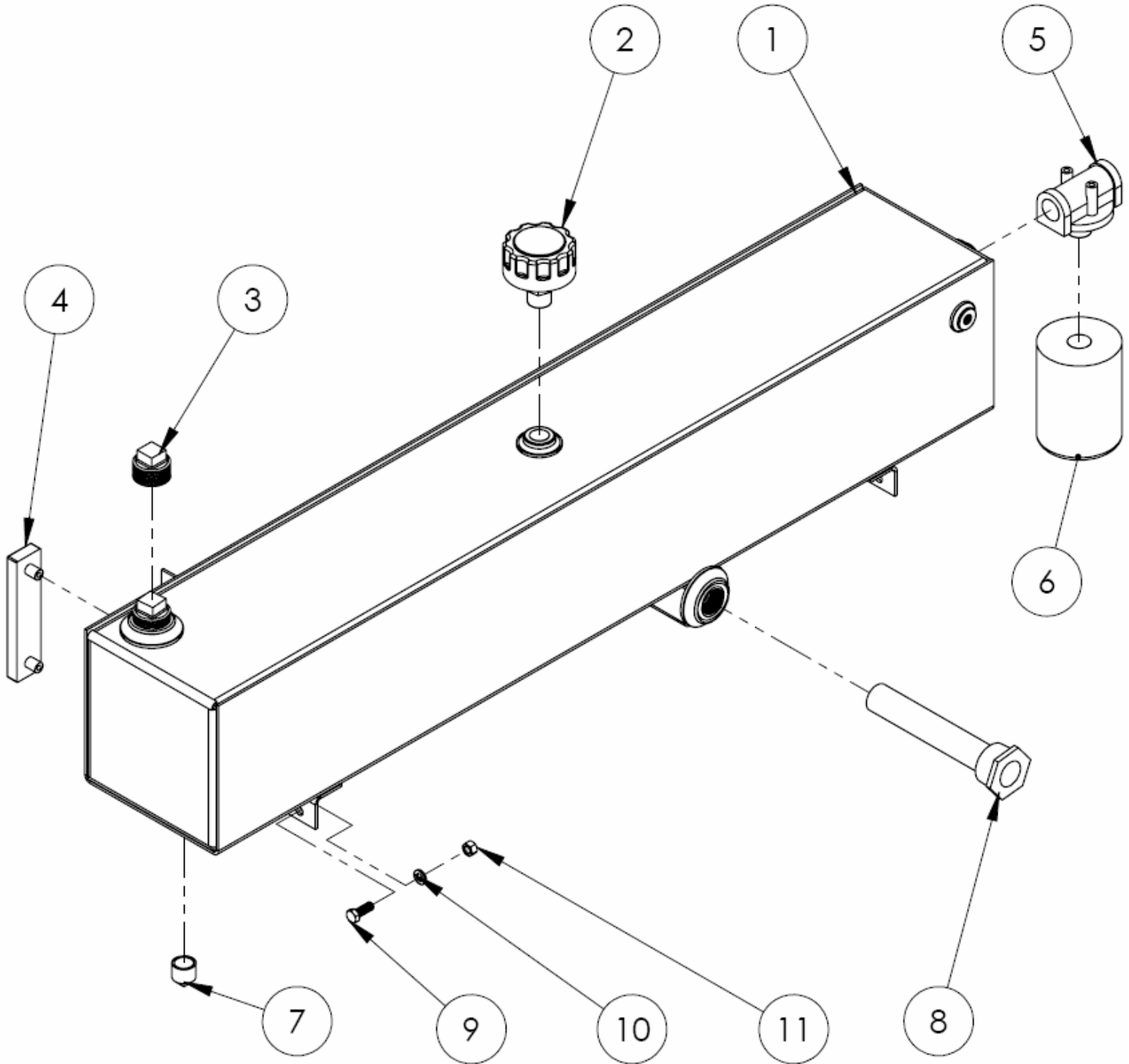

TL 5500AX2 Hydraulic Oil Tank

Item #	Qty	Part #	Description
1	1	TL5X2-100-190	Hydraulic Tank
2	1	TL500-100-169	Breather Cap
3	1	TL500-100-170	Filter Plug 1 ¼ Pipe
4	1	TL500-100-171	Sight Gauge
5	1	TL500-100-172	Filter Base
6	1	TL500-100-173	10 Micron Filter
7	1	TL500-100-174	3/4" Magnetic Plug
8	1	TL500-100-175	Suction Strainer
9	1	Obtain Locally	3/8 x 1 Bolt
10	1	Obtain Locally	3/8 Lockwasher
11	1	Obtain Locally	3/8 Nut

TL 5500AX2 Mud Flap

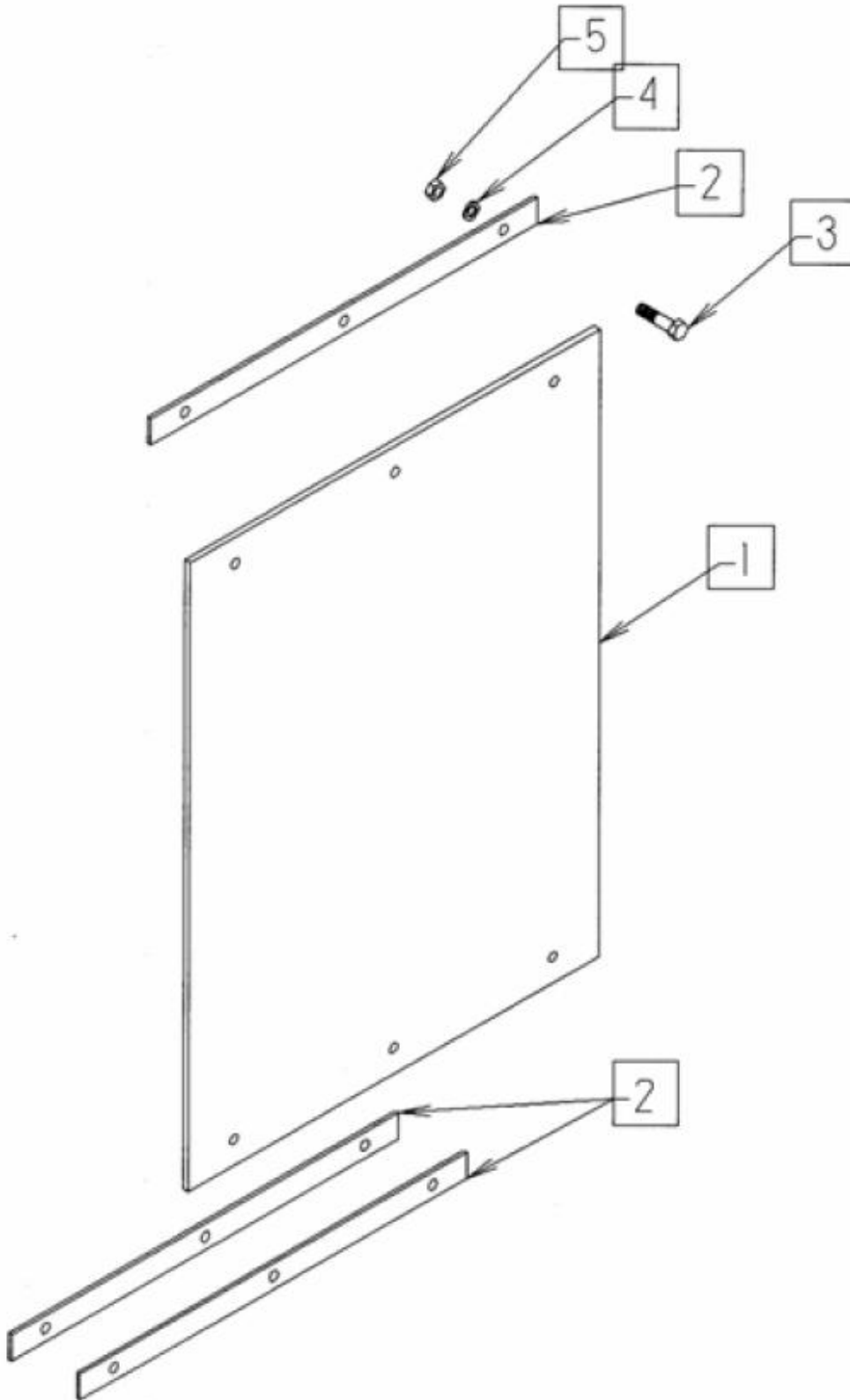

TL 5500AX2 Mud Flap

Item #	Qty	Part #	Description
1	1	TL550-100-054	Mud Flap
2	3	TL500-100-164	Metal Strip
3	1	Obtain Locally	5/16 x 1 Bolt
4	1	Obtain Locally	5/16 Lockwasher
5	1	Obtain Locally	5/16 Nut

TL 5500AX2 Engines

13HP Honda

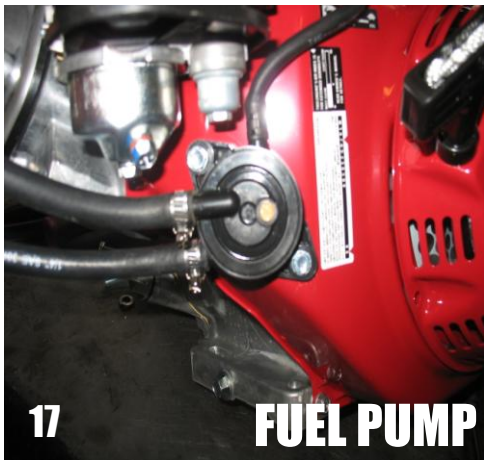
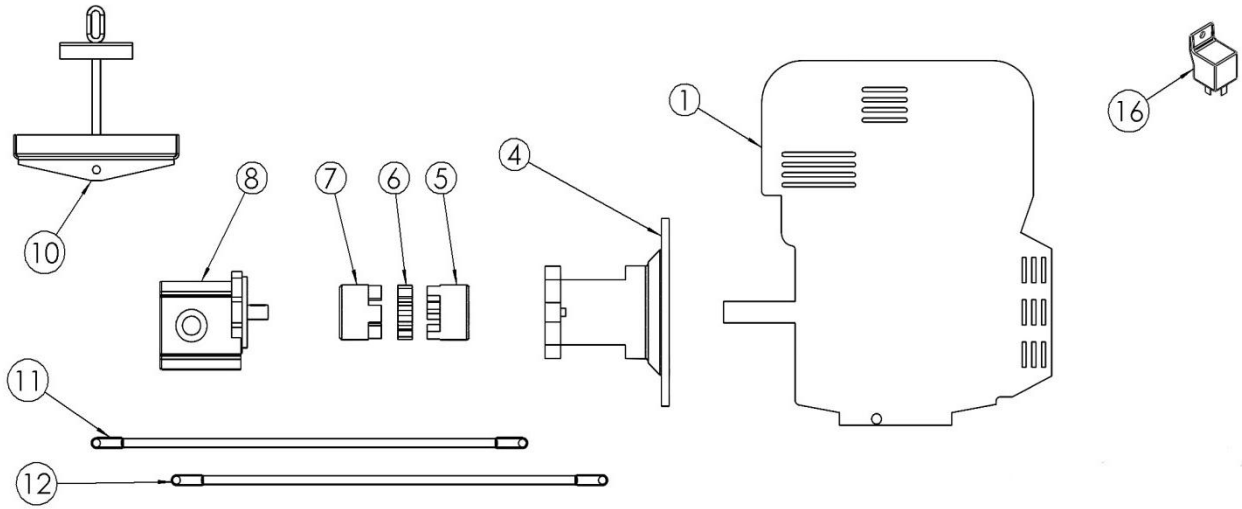

20HP Honda

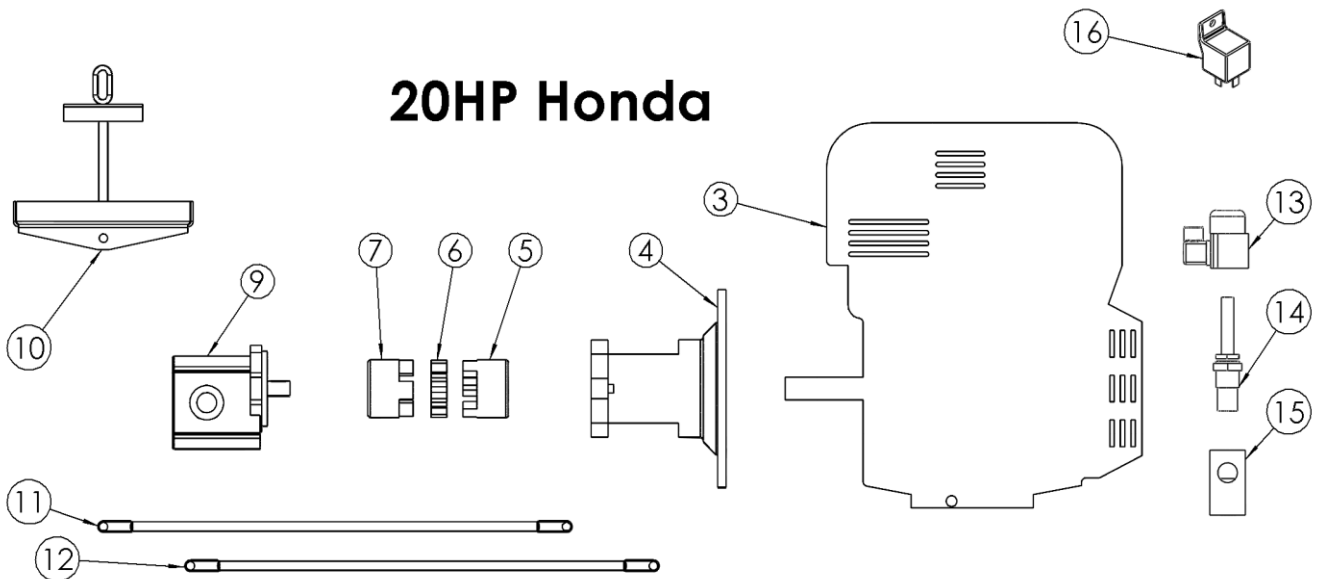

TL 5500AX2 Engines

Item	Qty	Part #	Description
1		TL5X2100200	13 HP HONDA ELECTRIC START
3		TL6X2100200	20 HP Honda Engine Electric Start
4	1	TL500100182	Engine – Pump Adapter
5	1	TL500100183	Love Joy Coupling Engine Side
6	1	TL500100184	Coupling Spacer
7	1	TL500100185	Love Joy Coupling Pump Side
8	1	TL500100181	Hydraulic Pump Casappa # PLP20-112
9	1	TL5X2101181	Hydraulic Pump Casappa # PLP20-14
10	1	TL500301221	Battery Hold Down
11	1	TL5X2500159	Red Battery Cable
12	1	TL5X2500160	Black Battery Cable
		TL5X2500161	Dump Valve (Ref # 13 - 15)
13	1	TL6X2102204	Dump Valve Solenoid
14	1	TL6X2102203	Dump Valve Cartridge
15	1	TL6X2102202	Dump Valve Base
16	1	TL500100220	35 amp Relay (mounted on 13hp & 20hp Honda)
17	1	TL25649	Fuel Pump (13hp only)
18	1	TL25591	Valve Cover Bolt (13hp only)

TL 5500AX2 Throttle Linkages

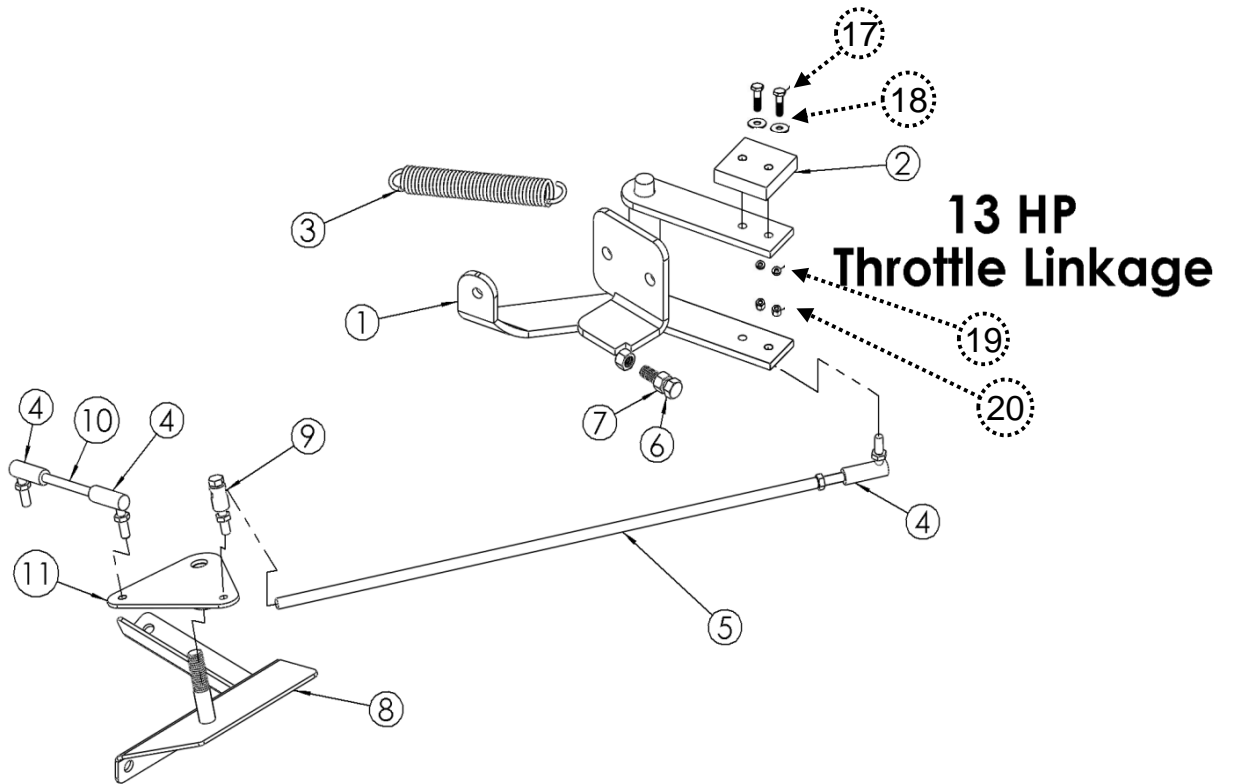

Prior to Serial # 10044

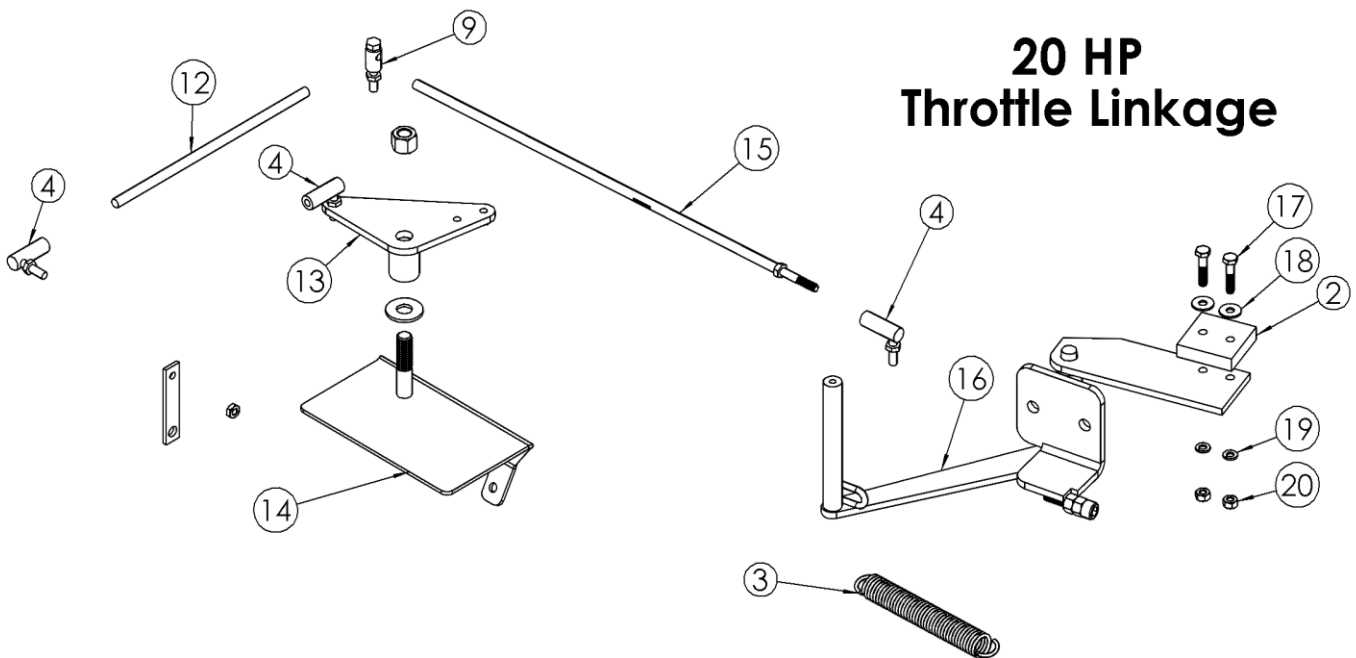

TL 5500AX2 Throttle Linkages

Serial # 10044 to current

20 HP Throttle Linkage

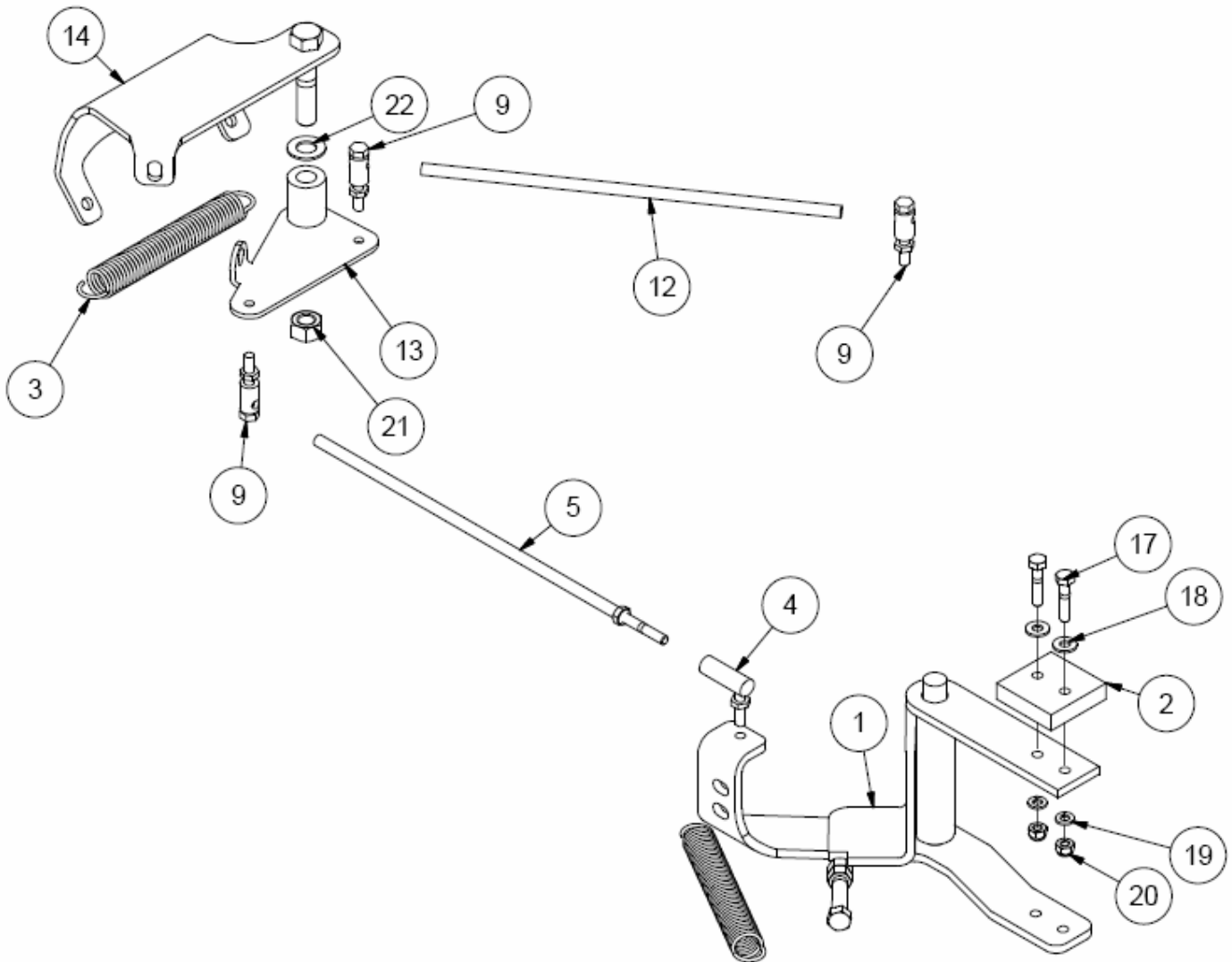

TL 5500AX2 Throttle Linkages

Item	Qty	Part #	Description
1	1	TL5X2-500-154	Main Link (Use for 20HP from Serial # 10044- current)
2	1	TL5X2-100-232	Striker Block
	1	TL550-100-069	Throttle Spring
4		TL550-100-065	Ball Joint
5	1	TL5X2-100-231	Control Rod
6	1	Obtain Locally	3/8-16 x 2 1/2 Bolt Gr.5
7	1	Obtain Locally	3/8-16 Jam Nut
8	1	TL599-100-067	13 HP Engine Throttle Base
9		TL550-100-067	Linkage Pivot
10	1	TL599-100-069	1/4-28 UNF Rod x 4
11	1	TL5X2-100-230	13 HP Swing Link
12	1	TL5X2-500-155	1/4-28 UNF Rod x 9 1/2
13	1	TL5X2-500-156	20 HP Swing Link
14	1	TL6X2-120-001	20 HP Engine Throttle Base
15	1	TL6X2-120-004	20 HP Control Rod
16	1	TL5X2-500-157	20 HP Main Link
17	2	Obtain Locally	1/4-20 x 1 1/4 Bolt Gr.5
18	2	Obtain Locally	1/4 Flatwasher
19	2	Obtain Locally	1/4 Lockwasher
20	2	Obtain Locally	1/4-20 Nuts
21	1	Obtain Locally	1/2 Steel Type Lock Nut
22	1	Obtain Locally	1/2 SAE Washer

★ 17,18,19,and 20 each have 2 items regardless of the linkage used

TL 5500AX2 Hydraulic Valve

Prior to Serial # 11022

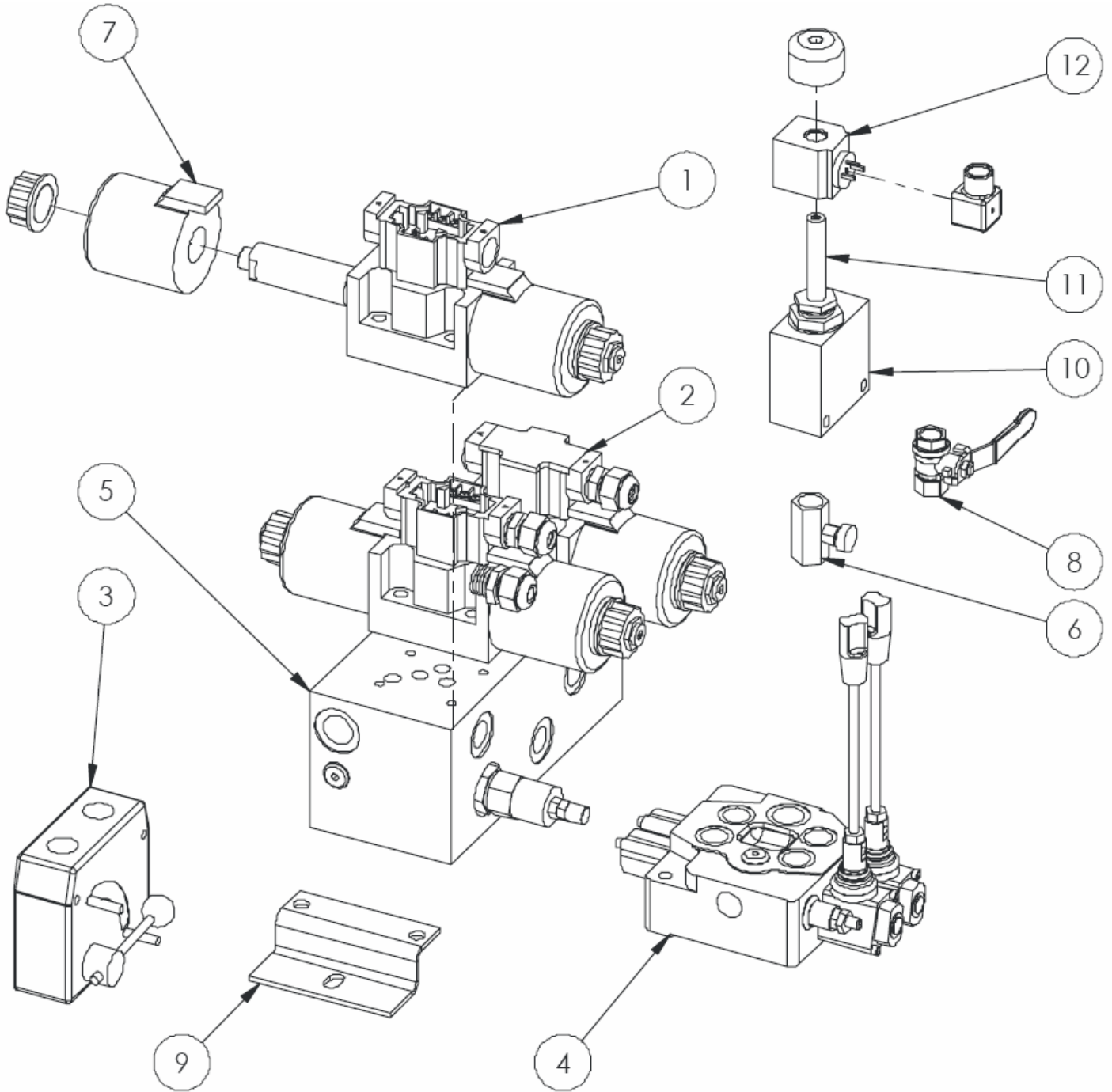

TL 5500AX2 Hydraulic Valve

Serial # 11023 to current

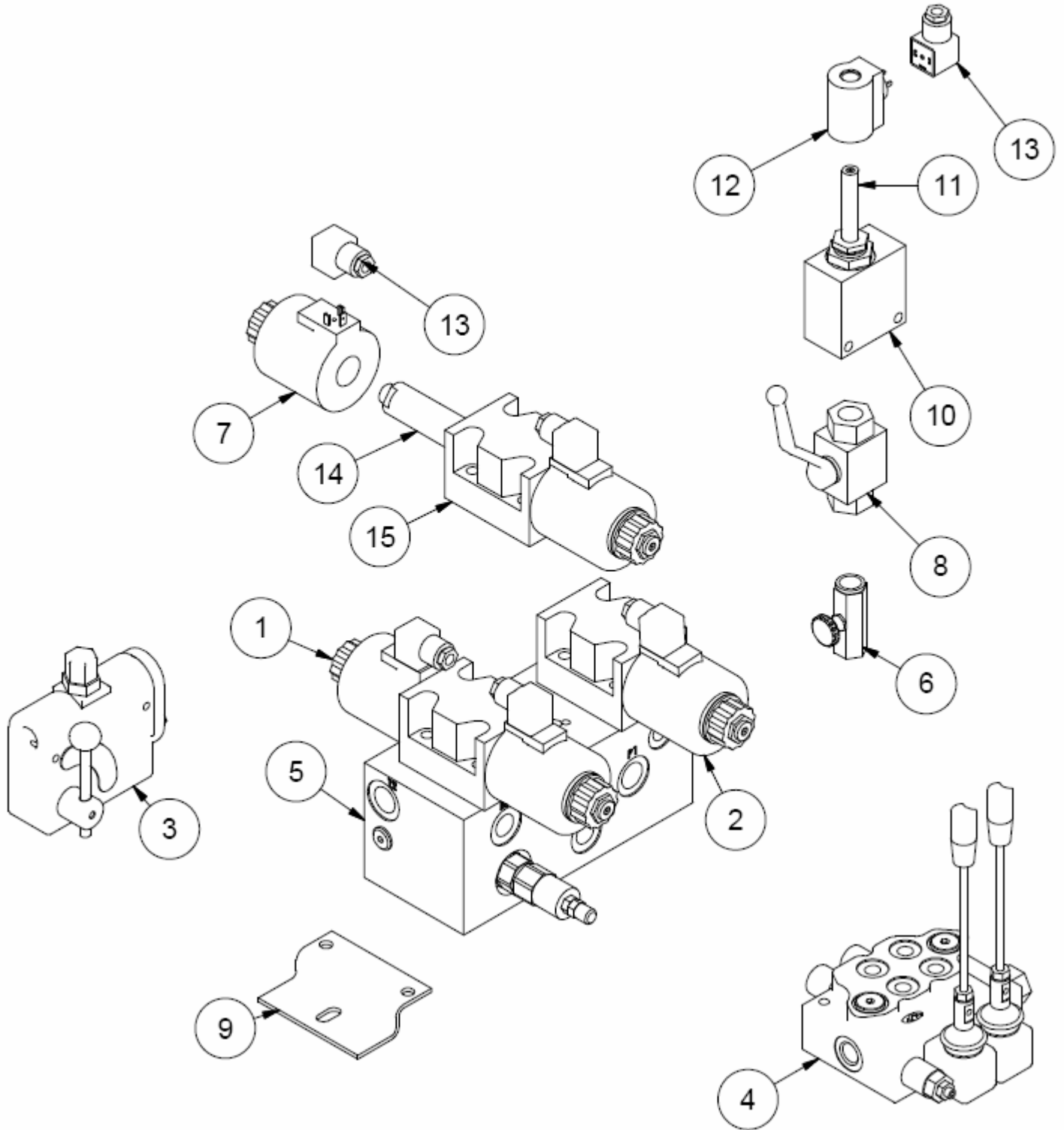

TL 5500AX2 Hystar Hydraulic Valve

Prior to Serial # 11022

Item	Qty	Part #	Description
1	2	TL5X2-201-200	Tandem Center 12 Volt DC Valve
2	1	TL5X2-201-201	Single 12 Volt DC Valve
3	1	TL500-100-193	Flow Control
4	1	TL5X2-201-055	2 Spool Mono-Block Valve
5	1	TL550-100-056	3 Station Custom Manifold
6	1	TL550-200-006	Steering Speed Control
7		TL5X2-201-007	Valve Coil
8	1	TL550-200-112	Ball Valve
9	1	TL550-200-113	Manifold Mount
10	1	TL850-301-109	Dump Valve Body (20 hp only)
11	1	TL850-301-110	Valve Cartridge (20 hp only)
12	1	TL850-301-111	12 Volt Coil (20 hp only)

Serial # 11023 to current

Item	Qty	Part #	Description
1	2	TL5X2-201-200	Tandem Center 12 Volt DC Valve
2	1	TL5X2-201-201	Single 12 Volt DC Valve
3	1	TL500-100-193	Flow Control
4	1	TL5X2-201-055	2 Spool Mono-Block Valve
5	1	TL550-100-056	3 Station Custom Manifold
6	1	TL550-200-006	Steering Speed Control
7		TL5X2-201-007	Valve Coil
8	1	TL550-200-112	Ball Valve
9	1	TL550-200-113	Manifold Mount
10	1	TL850-301-109	Dump Valve Body (20 hp only)
11	1	TL850-301-110	Valve Cartridge (20 hp only)
12	1	TL850-301-111	12 Volt Coil (20 hp only)
13	5	28534	DIN Connector
14	5	VAL25288	Tube Assembly
15	3	VAL25285	Valve Body

TL 5500AX2 Control Panel

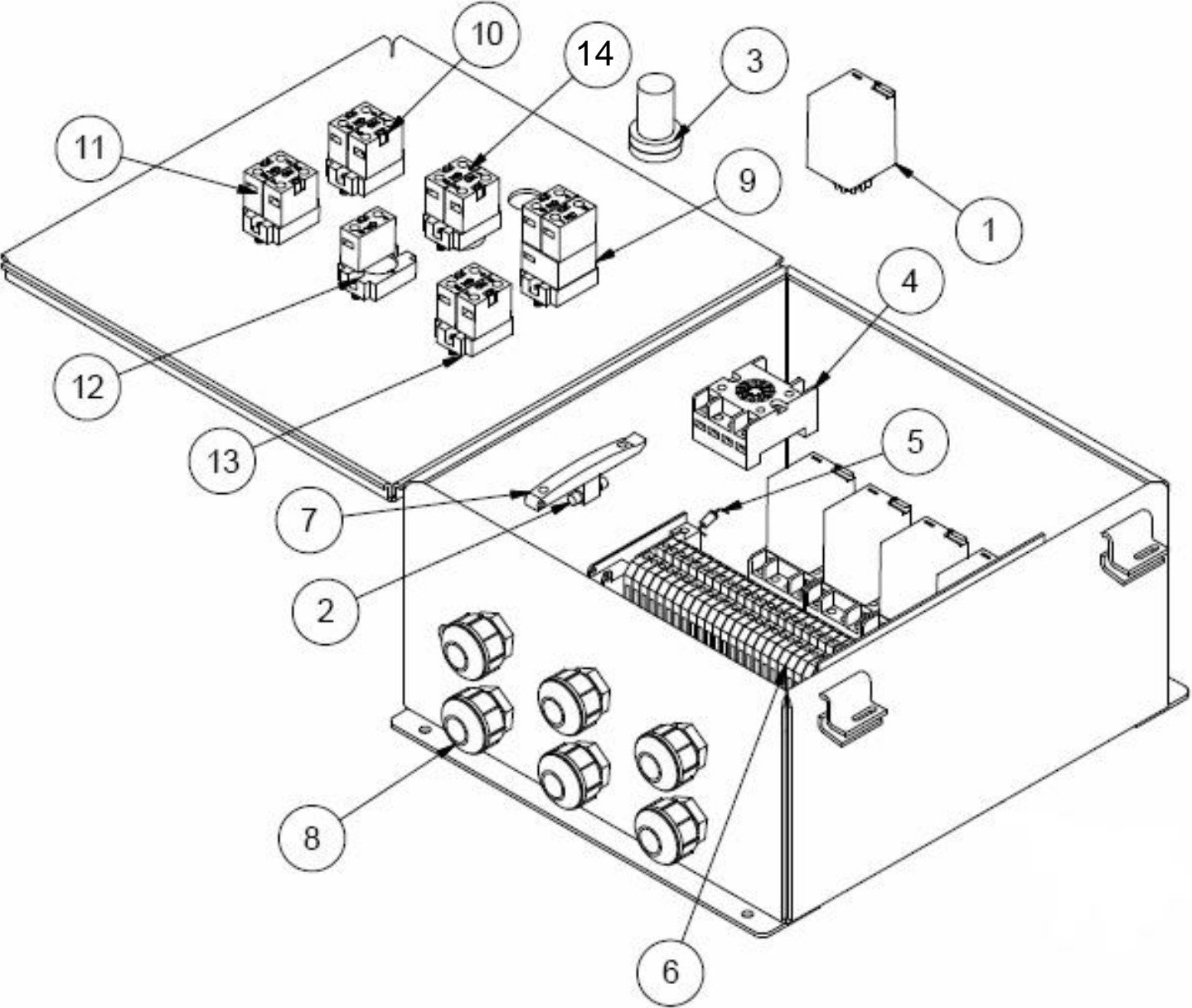

TL 550AX2 Control Panel

Item	Qty	Part	Description
	1	TL550-200-061	Complete Control Panel
1	5	TL500-100-221	Control Relay
2	1	TL550-100-079	15 AMP Fuse
3	1	TL27299	LED Light
4	5	TL5X2-500-158	11 Pin Relay Base
5	1	TL550-150-085	Diode 1N5406 3amp 600V
6	26	TL550-150-084	DIN Rail Terminal Block
7	1	TL550-150-083	DIN Rail Fuse Holder
8	6	TL550-100-086	PVC Wire Holder
9	1	TL25762	On/Off Switch
10	1	TL550-100-076	Man/Auto Switch
11	1	TL550-100-077	Steering Switch
12	1	TL550-100-075	Rotate Switch
13	1	TL550-100-077	Forward/ Reverse Switch
14	1	TL27298	Emergency Stop Button

TL 550AX2 Limit Switch

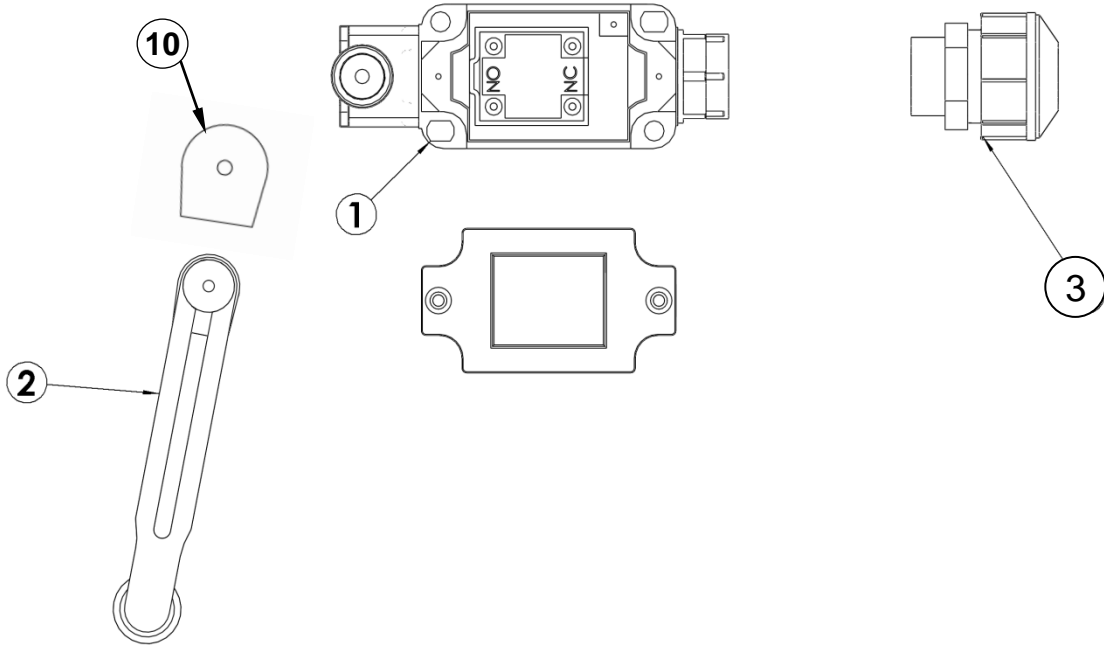

On/Off - Man/Auto Switch

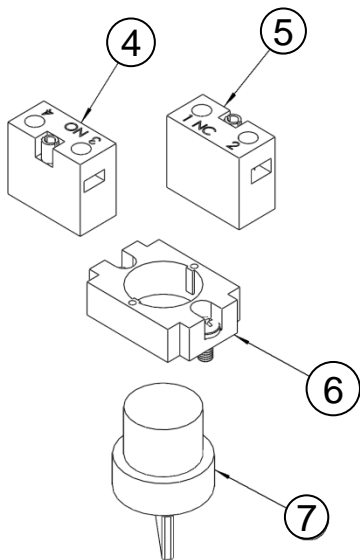

Rotate Switch

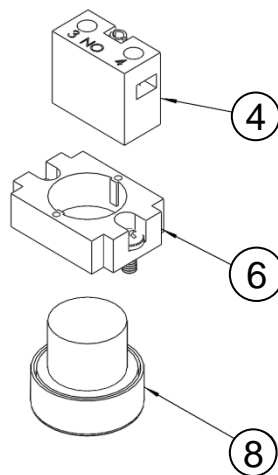

Ram - Steering Switch

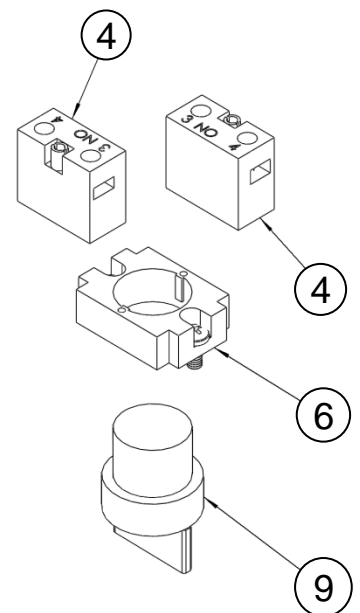

TL 550AX2 Limit Switch

Item	Qty	Part #	Description
1	5	TL550-100-060	Complete Limit Switch (Ref # 1, 2, & 4)
2	5	TL550-100-059	Limit Switch Arm
3	1	TL550-100-086	PVC Box Connector
4	7	TLRB2BE101	Contact Block Normally Open (NO)
5	2	TLRB2BE102	Contact Block Normally Closed (NC)
6	5	TLRB2B	Switch Mount Collar
7	1	TLRB2BD2	Selector Switch – 2 Position
8	1	TLRB2BA2	Push Button
9	1	TLRB2BDR3	Selector Switch – 3 Position Spring Return
	2	TL550-100-076	On/Off – Man/Auto Switch (Complete)
	1	TL550-100-075	Rotate Switch (Complete)
	2	TL550-100-077	Ram/Steering Switch (Complete)
10	1	TL550-100-082	Wire Clamp

TL 5500AX2 Bale Switch

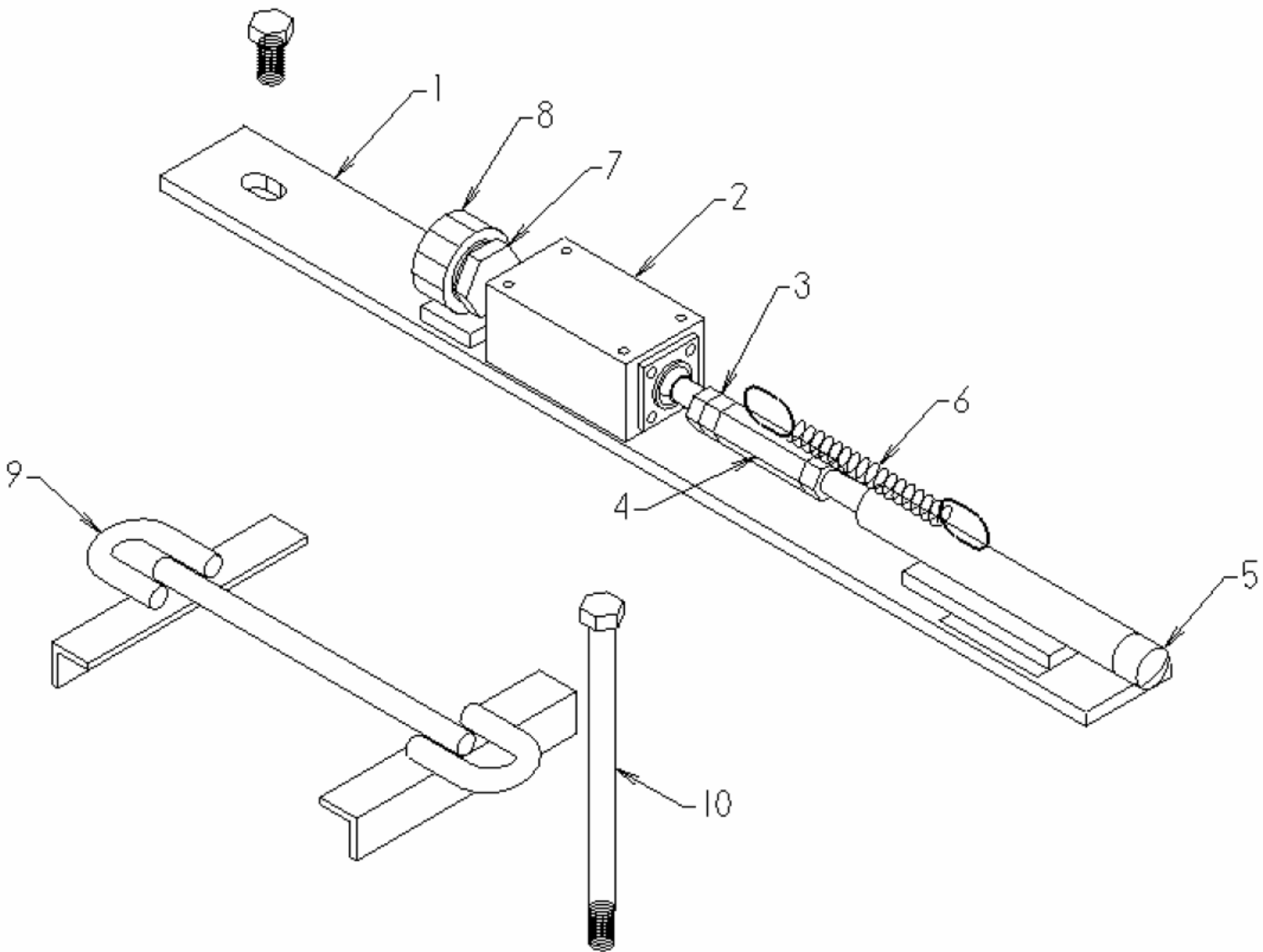

TL 5500AX2 Bale Switch

Item	Qty	Part #	Description
1	1	TL5X2-100-220	Switch Base
2	1	TL5X2-100-221	Switch
3	1	TL500-100-046	3/8 x 1 Bolt
4	1	TL5X2-100-222	3/8 Coupling Nut
5	1	TL5X2-100-223	Push Rod
6	1	TL500-100-062	Spring
7	1	TL550-200-086	Adaptor, metric to inch
8	1	TL550-100-082	Wire Clamp
9	1	TL500-301-221	Battery Hold-down
10	1	TL500-100-212	Battery Bolts

TL 5500AX2 Fuel Tank

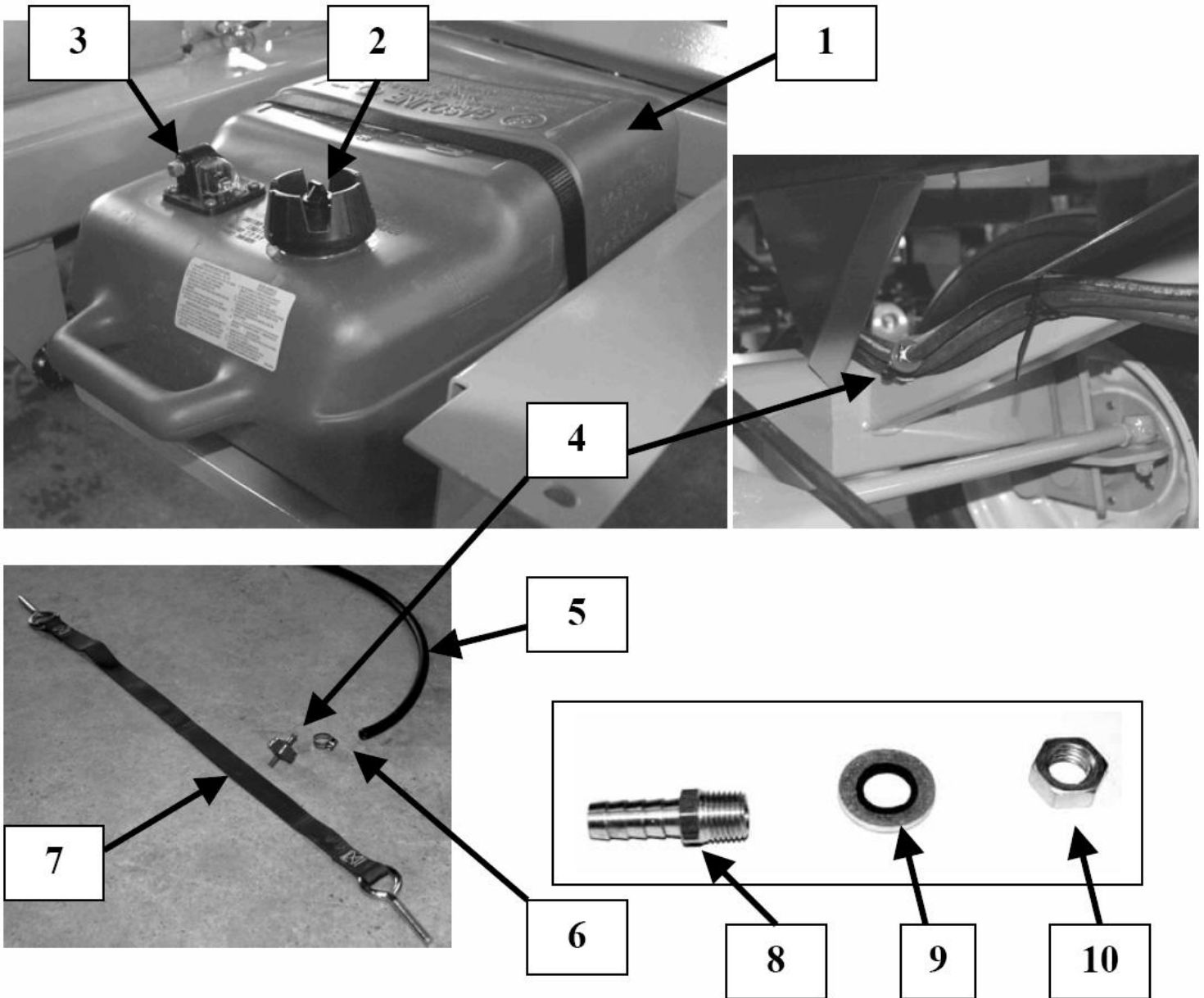

TL 5500AX2 Fuel Tank

Item #	Qty	Part #	Description
1	1	TL550-204-100	Fuel Tank
2	1	TL550-204-101	Vented Cap
3	1	TL550-204-103	Fuel Gauge Cap
4	1	TL550-200-111	Fuel Filter
5	1	TL5X2-201-107	Fuel Line
6	1	TL550-204-109	Hose Clamp
7	1	TL550-204-110	Tie Down Strap
8	1	TL5X2-201-108	Hose Adaptor
9	1	TL5X2-201-109	Sealing Washer
10	1	TL5X2-100-234	Adaptor Nut

TLR 5000X2 Film Sensor

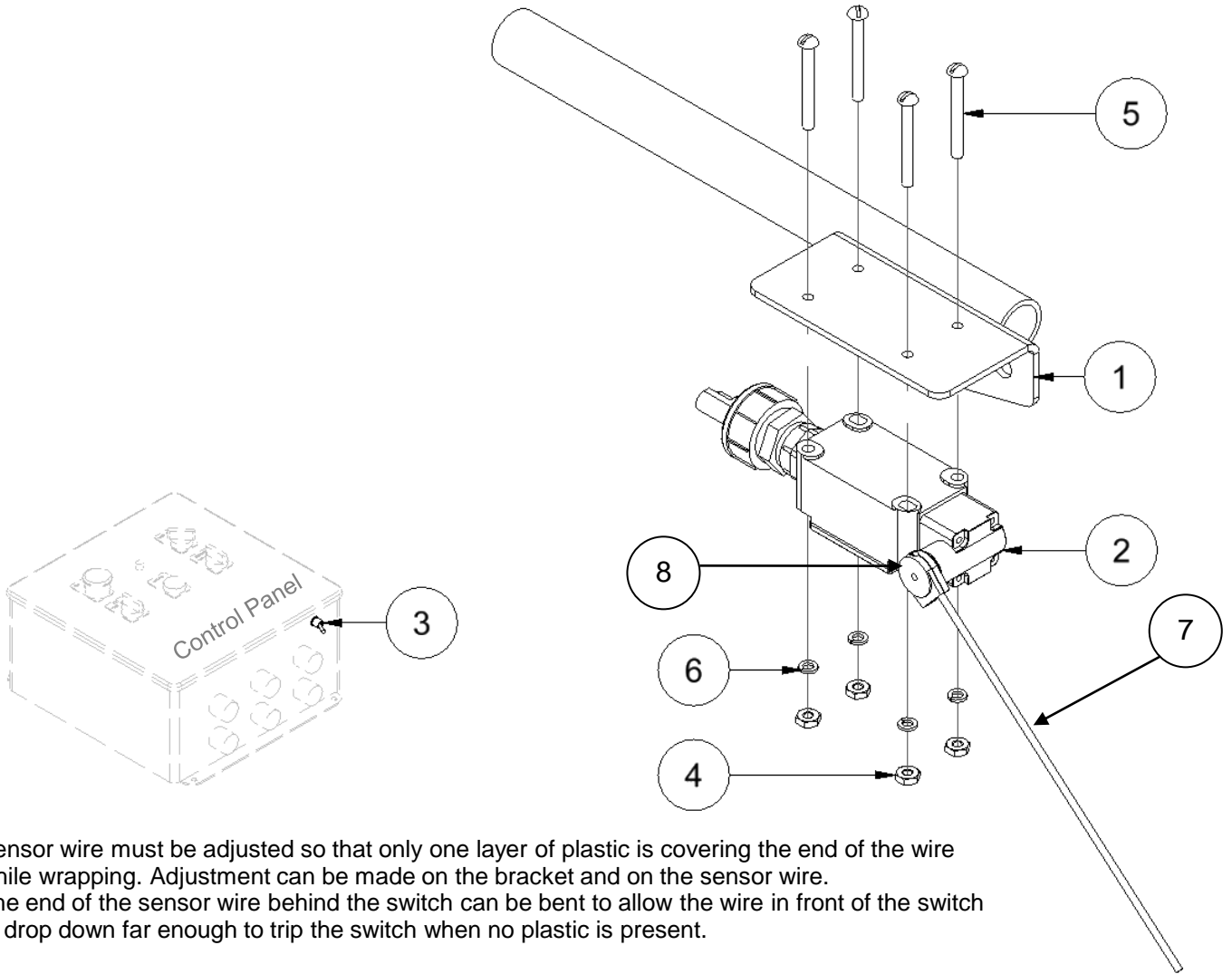

Sensor wire must be adjusted so that only one layer of plastic is covering the end of the wire while wrapping. Adjustment can be made on the bracket and on the sensor wire. The end of the sensor wire behind the switch can be bent to allow the wire in front of the switch to drop down far enough to trip the switch when no plastic is present.



Film sensor location

TLR 5000X2 Film Sensor

Item	Qty	Part #	Description
	1	TLFSSK	Complete Kit
1	1	TLFSB2007	Film Sensor Bracket
2	1	TL109-100-348	Film Sensor Limit Switch (Complete)
3	1	TL550-200-235	Toggle Switch
4	4	Obtain Locally	10-24 Hex Nut
5	4	Obtain Locally	10-24 x 1.75 Machine Screw
6	4	Obtain Locally	#10 Lock Washer
	2	Obtain Locally	12" Wire (Terminal 18 & 19)
7	1	TL550-100-049	Wire Arm
8	1	TL550-100-082	Wire Clamp

Installation

- Install and adjust film sensor bracket
- Locate the wire labeled film sensor (pre-wired machine)
- Remove the plug and connect to film sensor switch
- Install toggle switch in the control panel
- Remove the jumper wire between terminal 18 & 19
- Connect wires from toggle switch to terminal 18 & 19

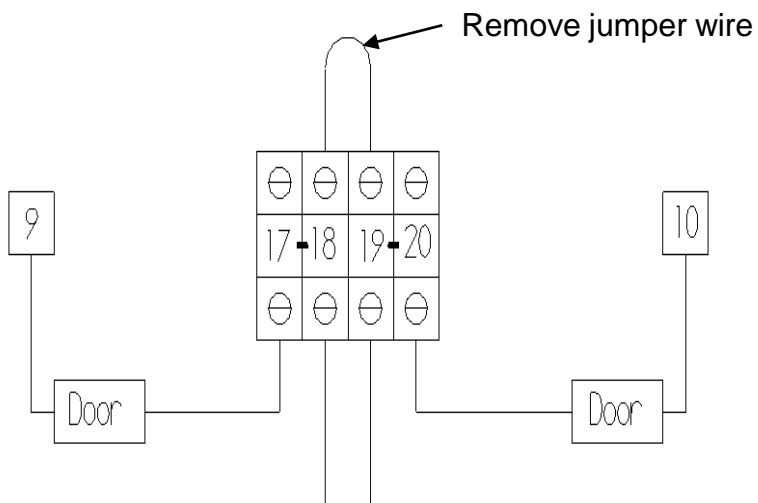

TL 5500AX2 Running Lights

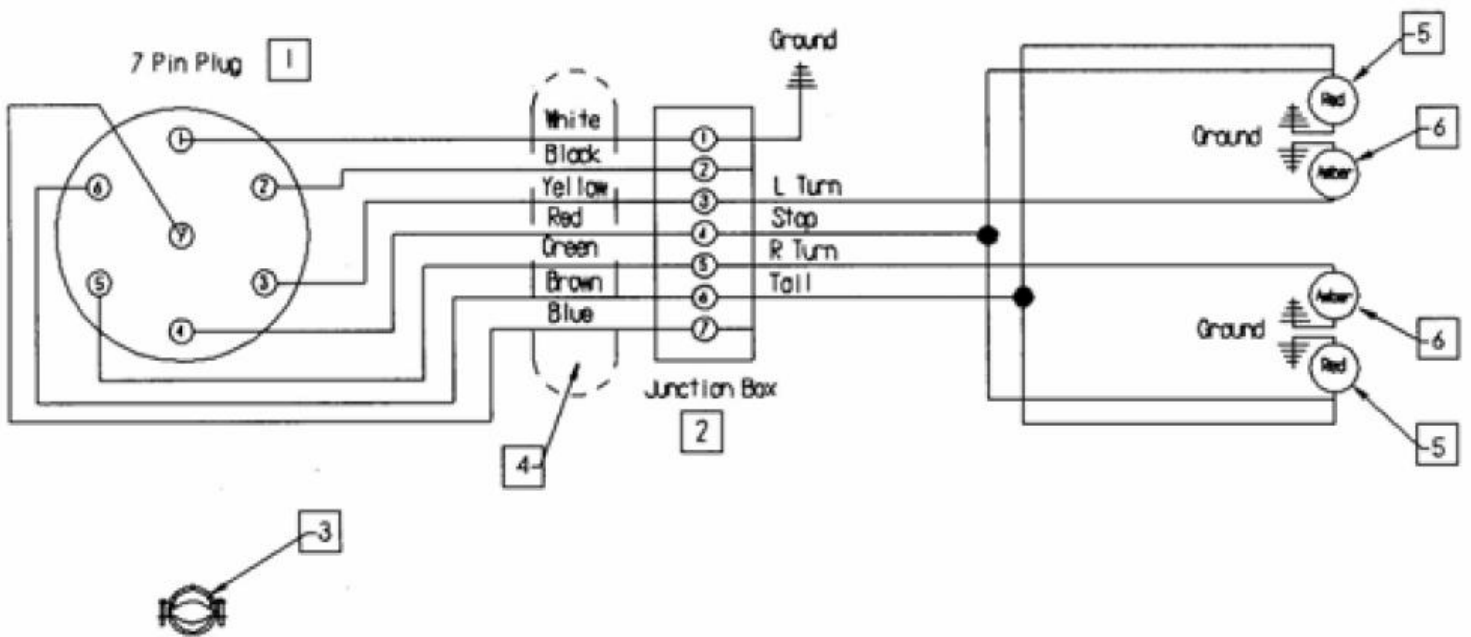

TL 5500AX2 Running Lights

Item #	Qty	Description	Part #
1	1	TL550-200-117	7 Pin Plug
2	1	TL550-200-118	Junction Box
3	1	TL550-200-119	Strain Relief
4	1	TL550-200-120	7 Wire Conductor
5	2	TL550-200-121	Red Lamp
6	2	TL550-200-122	Amber Lamp

Hydraulic Schematic

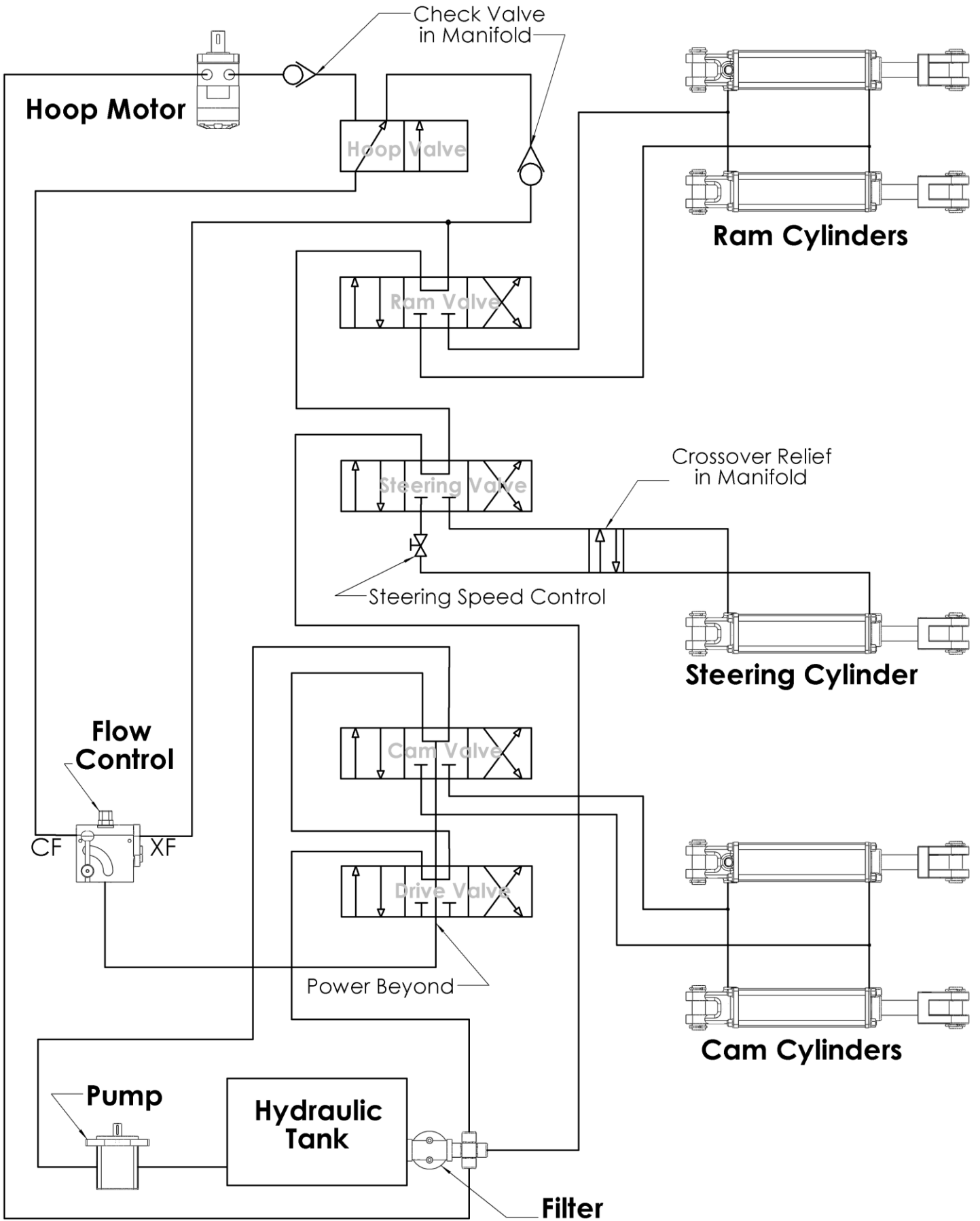

TL 5500AX2 Electric Schematic

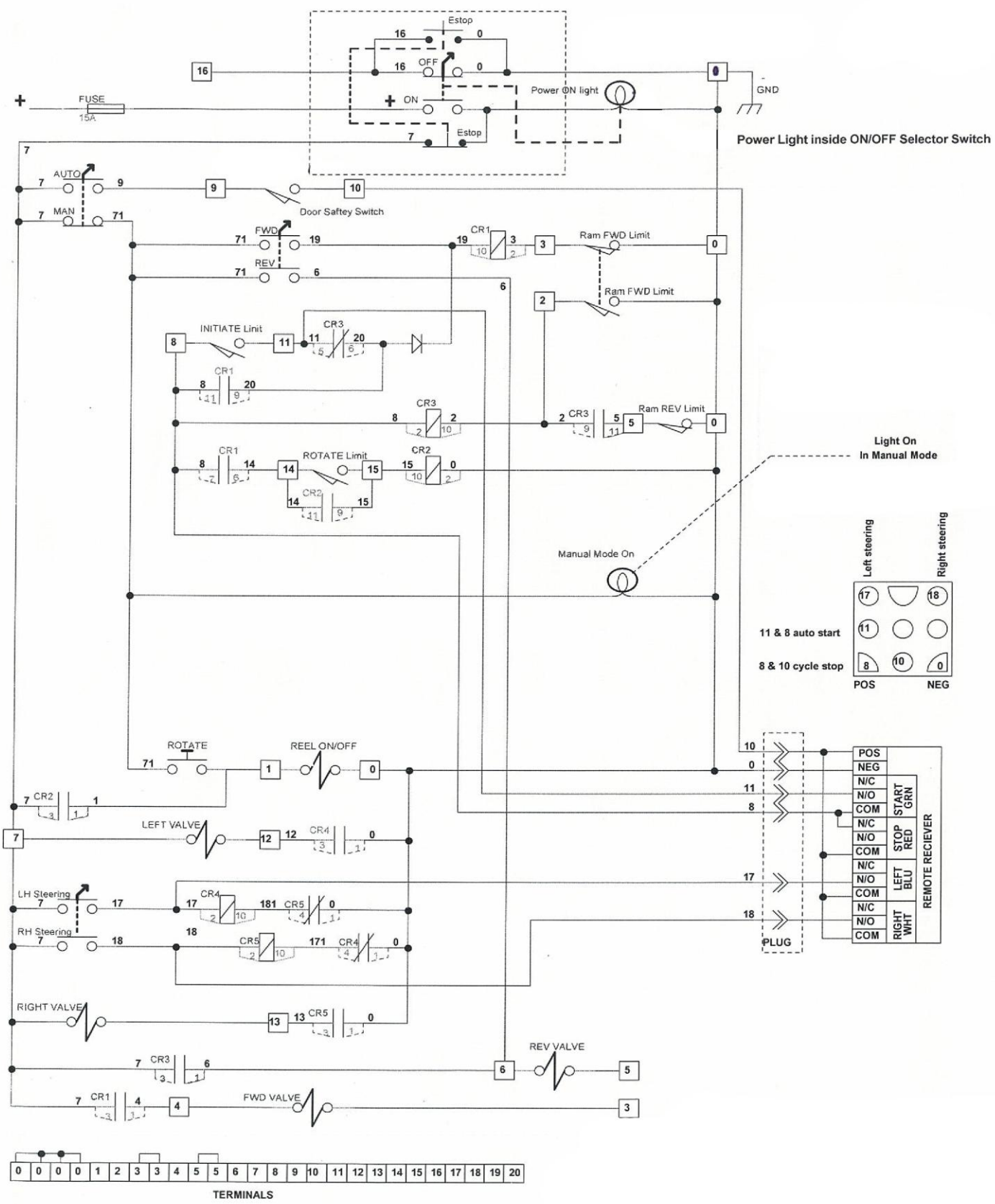

Power Light inside ON/OFF Selector Switch

Light On
In Manual Mode

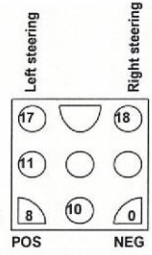

11 & 8 auto start
8 & 10 cycle stop

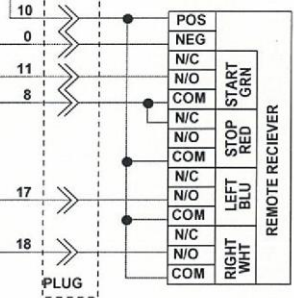

WIRING DIAGRAM

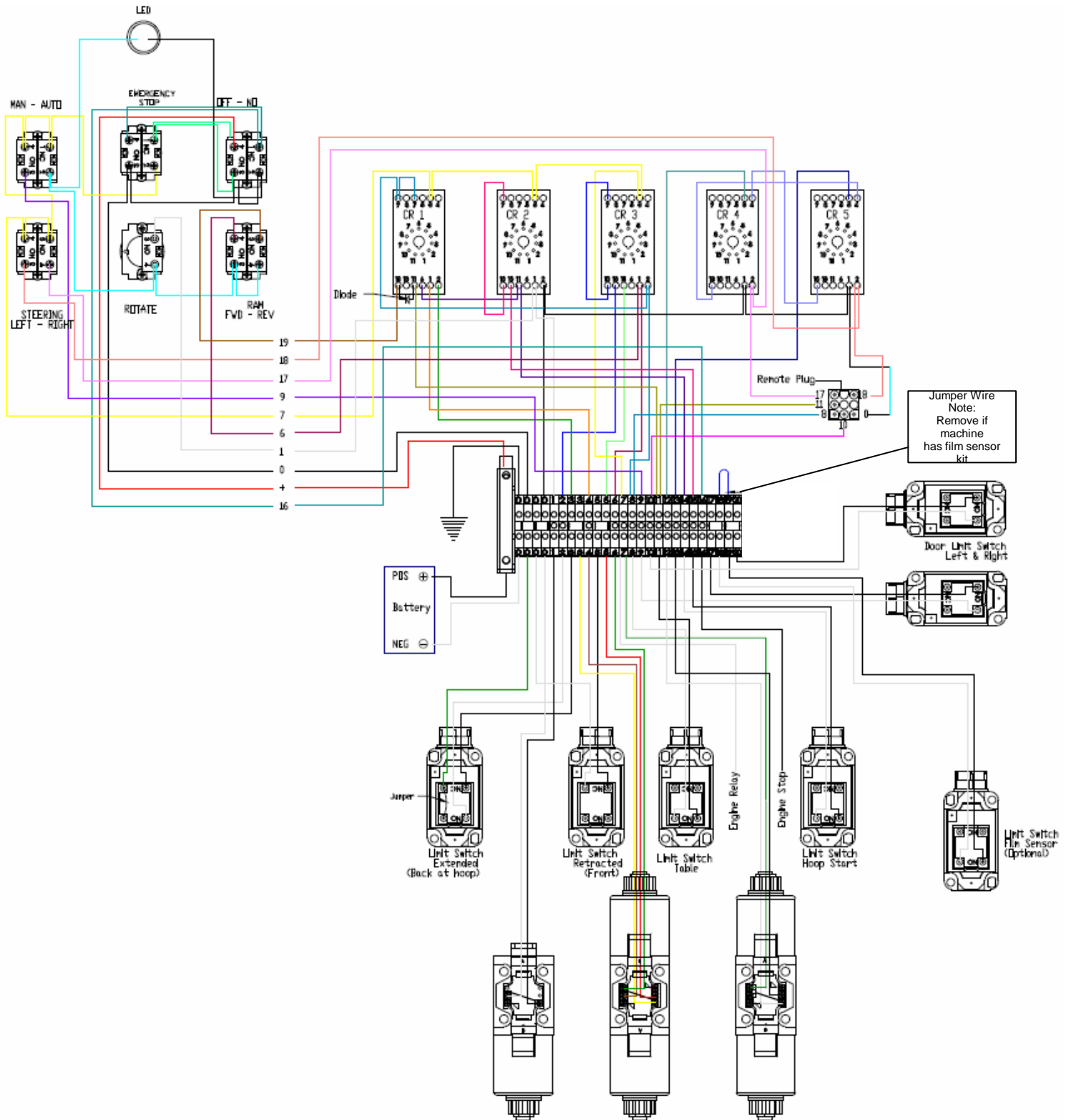

AVAILABLE OPTIONS

- SINGLE POWER DRIVE
- DUAL POWER DRIVE
- LIGHT KIT
- REMOTE CONTROL
- GUIDE ROLLER KIT
- TWIN WRAP KIT
- QUICK START POWER JACK

Optional Single Power Drive

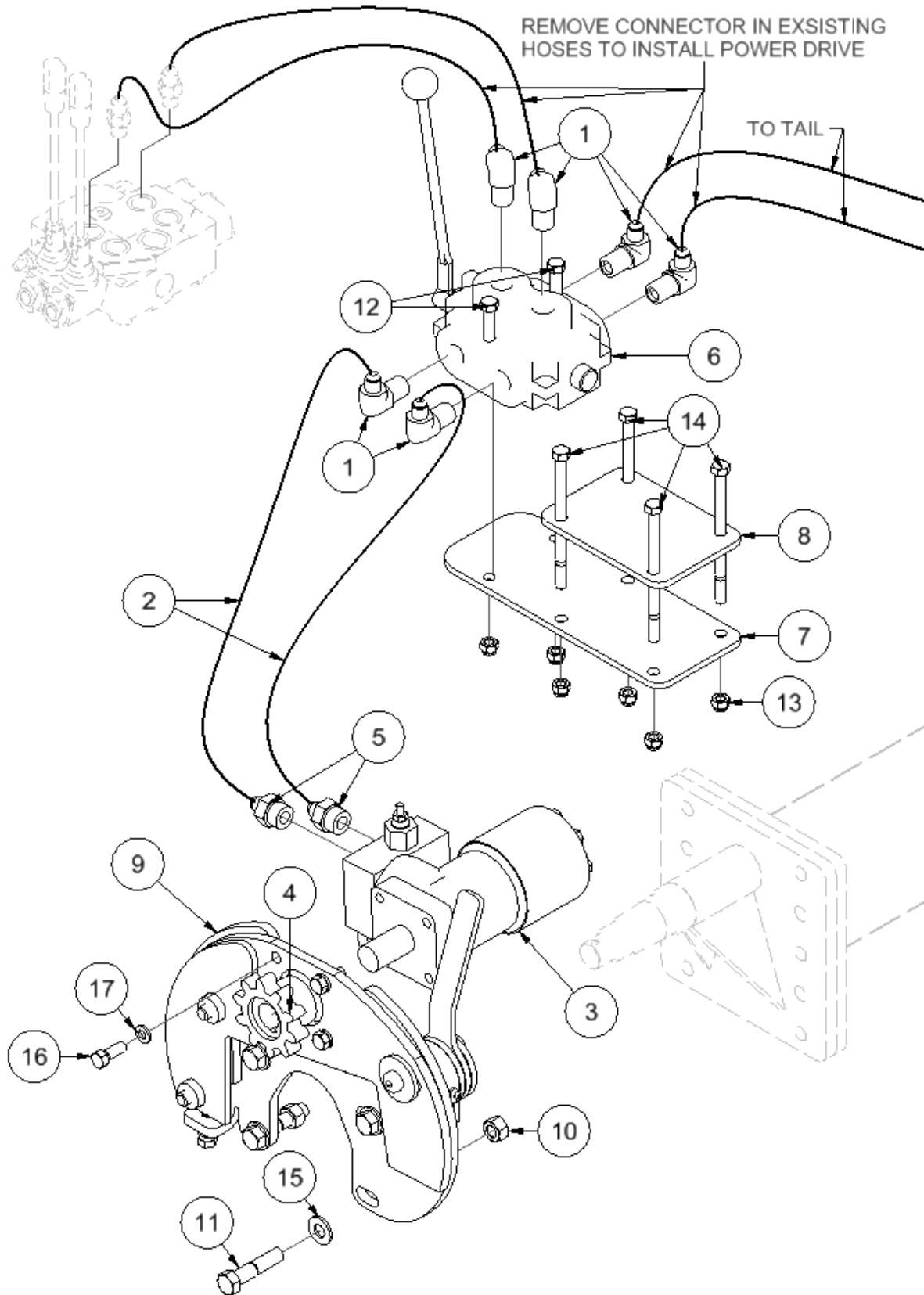

Optional Single Power Drive

Item	Qty	Part #	Description
1	6	HF2501-6-8	Hydraulic Fitting
2	1	25113	HH14 - 6AT1(6FJX
3	1	TL550-200-138	Hydraulic Motor
4	1	TL550-203-237	Sprocket
5	2	HF6400-6-10	Hydraulic Fitting
6	1	VAL DS1A1E	Selector Valve
7	1	TLWHEEL13	Selector Valve Mount
8	1	TLWHEEL13A	Selector Valve Mount
9	1	TLWHEEL32	Power Drive Assembly
10	4	Obtain Locally	HN 1/2 Hex Nut UNF
11	4	Obtain Locally	HB 1/2 X 2 1/4 Hex Bolt UNF
12	2	Obtain Locally	HB 3/8 X 3 Hex Bolt
13	6	Obtain Locally	LN 3/8 Lock Nut
14	4	Obtain Locally	HB 3/8 X 5 1/2 Hex Bolt
15	4	Obtain Locally	FW 1/2" Flatwasher
16	4	Obtain Locally	HB 3/8 X 1 Hex Bolt
17	4	Obtain Locally	LW 3/8" Lockwasher

Optional Dual Power Drive

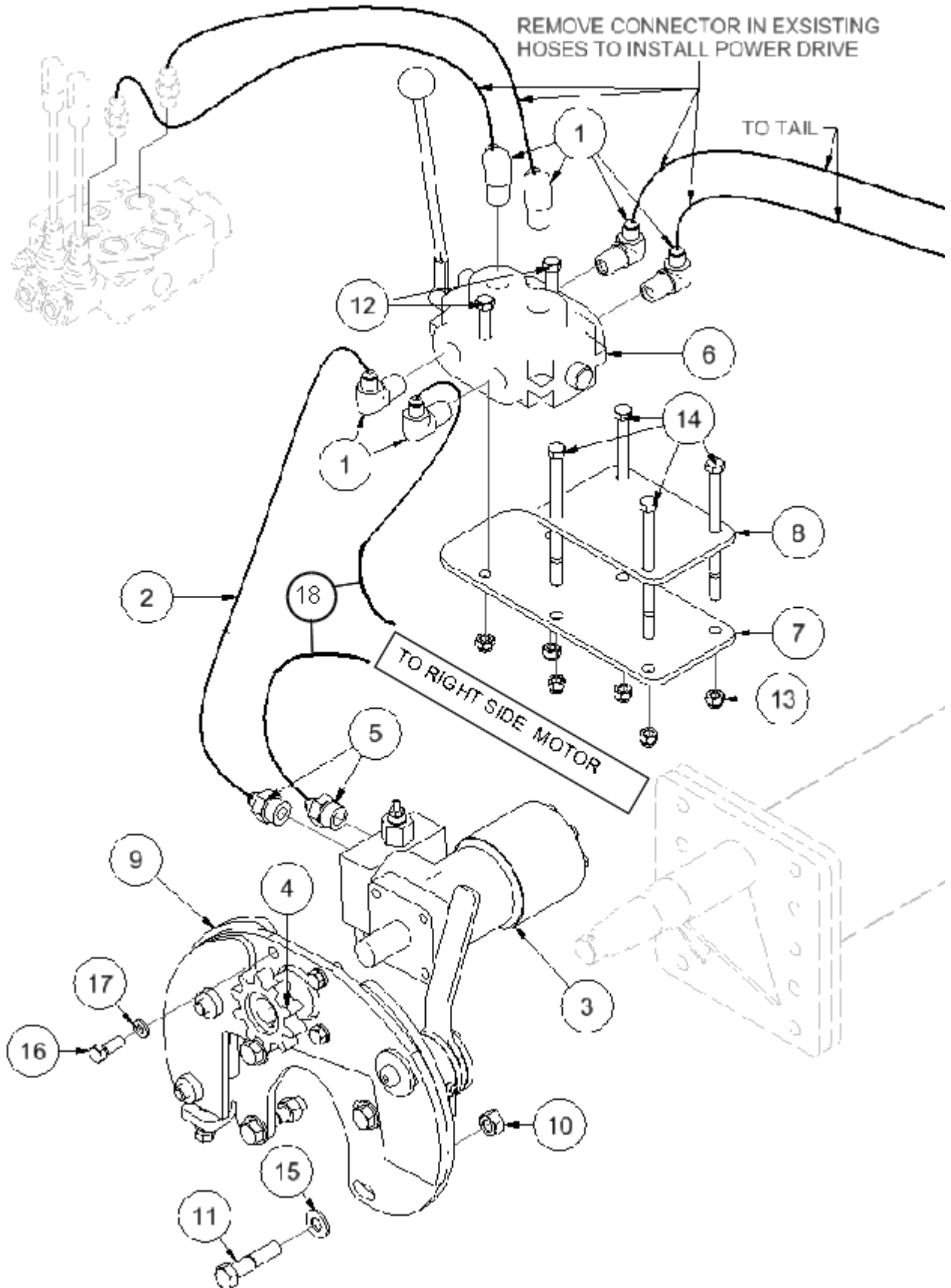

Optional Dual Power Drive

Item	Qty	Part #	Description
1	6	HF2501-6-8	Hydraulic Fitting
2	1	25113	HH14 - 6AT1(6FJX
3	2	TL550200138	Hydraulic Fitting
4	2	TL550203237	Sprocket
5	4	HF6400-6-10	Hydraulic Fitting
6	1	VAL DS1A1E	Selector Valve
7	1	TLWHEEL13	Selector Valve Mount
8	1	TLWHEEL13A	Selector Valve Mount
9	2	TLWHEEL32	Power Drive Assembly
10	8	Obtain Locally	HN 1/2 Hex Nut UNF
11	8	Obtain Locally	HB 1/2 X 2 1/4 Hex Bolt UNF
12	2	Obtain Locally	HB 3/8 X 3 Hex Bolt
13	6	Obtain Locally	LN 3/8 Lock Nut
14	4	Obtain Locally	HB 3/8 X 5 1/2 Hex Bolt
15	8	Obtain Locally	FW 1/2" Flat washer
16	8	Obtain Locally	HB 3/8 X 1 Hex Bolt
17	8	Obtain Locally	LW 3/8" Lockwasher
18	2	24114	HH64 - 6AT1(6FJ,6FJX)HCL 64

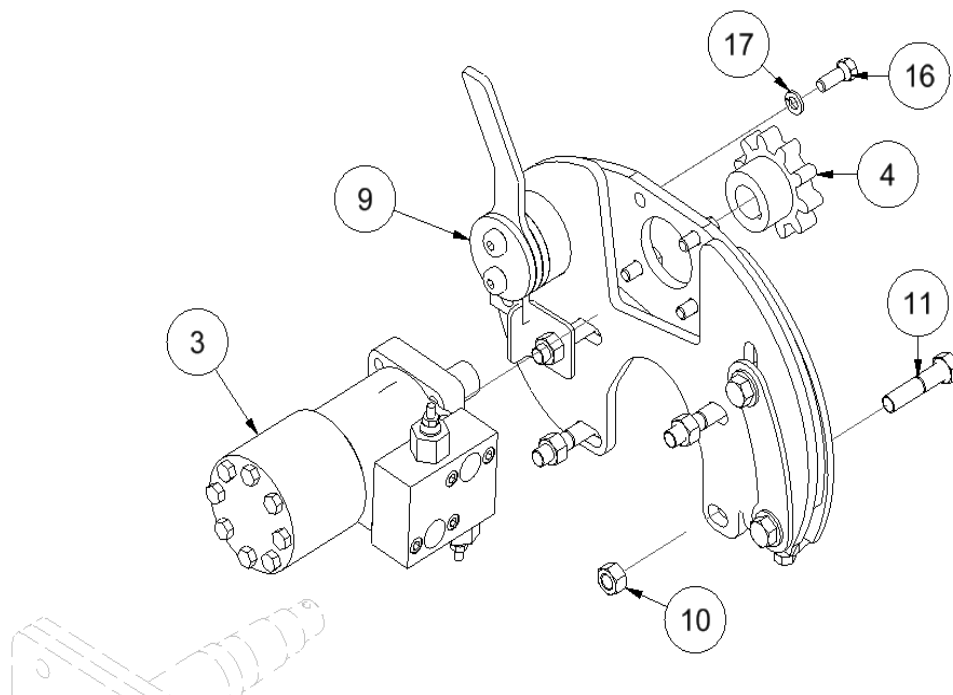

Optional Light Kit

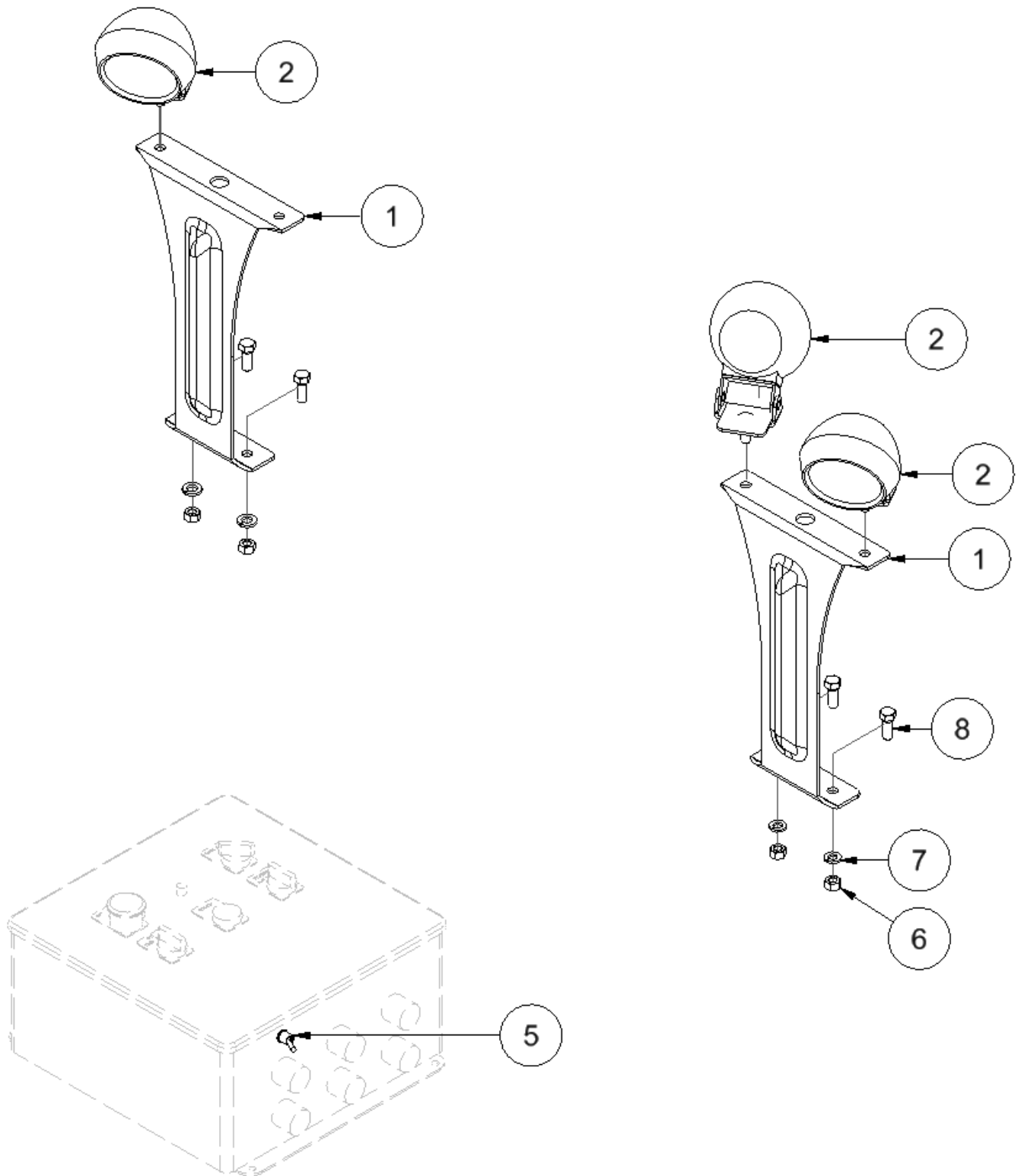

Optional Light Kit

Item	Qty	Part #	Description
		TLNWLK	Complete Kit
1	2	TL5X2-100-201	Light Bracket
2	3	TL-64931B	Light
3	1	Obtain Locally	15 AMP Fuse
4	1	Obtain Locally	Fuse Holder
5	1	Obtain Locally	Toggle Switch
6	4	Obtain Locally	HN 3/8" (Hex Nut)
8	2	Obtain Locally	LW 3/8" (Lock Washer)
9	4	Obtain Locally	HB 3/8" X 1" (Hex Bolt)

Installation

- Mounting location is at the top of the hoop guards
- Drill a 1/2" hole in the bottom of the control panel for the toggle switch
- Install the switch, locate the 2 wires labeled lights inside the control panel and connect them to the one terminal on the toggle switch
- Connect the inline fuse from the toggle switch to the bottom of the fuse block (fuse block is located at the left side of the terminal strip)

Optional Remote Control

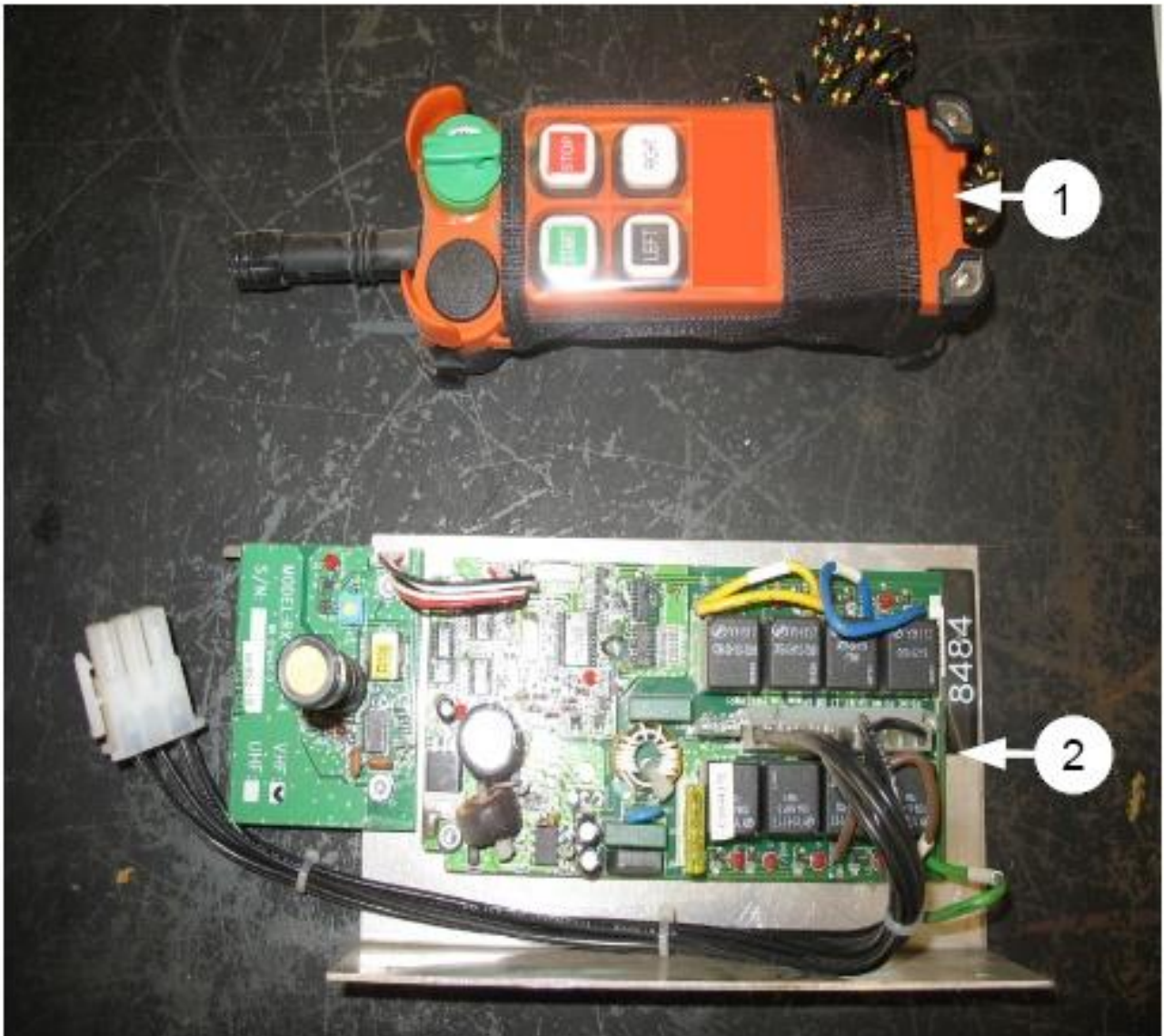

Optional Remote Control

Item	Qty	Part #	Description
		RSSKX2HD	Remote Control Kit
1	1	TLBHHCX2HD	Handheld Unit
2	1	TLRSSKX2HDL	Receiver Unit

Installation

- Bolt receiver assembly to inside rear right of control box with connector plug at bottom.
- Locate the plug with 6 wires inside the control panel.
- Remove the jumper plug and connect the remote control board.

Notice : All remote control units use the same frequency, no programming is required.

.ON/OFF – TURNS HANDHELD UNIT ON/OFF (DETENT HAS NO FUNCTION)

.START – STARTS THE WRAP CYCLE (UNPLUG THE TABLE SWITCH IF YOU PREFER TO START EACH CYCLE WITH THIS BUTTON) THIS WILL NOT START THE RESTART THE HOOP IF CYCLE IS BROKEN AFTER THE HOOP START WAS TRIGGERED

.STOP – STOPS THE WRAP CYCLE (IF THE TABLE SWITCH IS NOT UNPLUGGED AND IT HAS A BALE HOLDING IT DOWN, IT IS NESSECARY TO HOLD STOP UNTIL THE CIRCUIT IS BROKEN BY SWITCHING TO MANUAL MODE AT THE CONTROL PANEL)

.LEFT- STEERS LEFT

.RIGHT- STEERS RIGHT

Optional Guide Roller

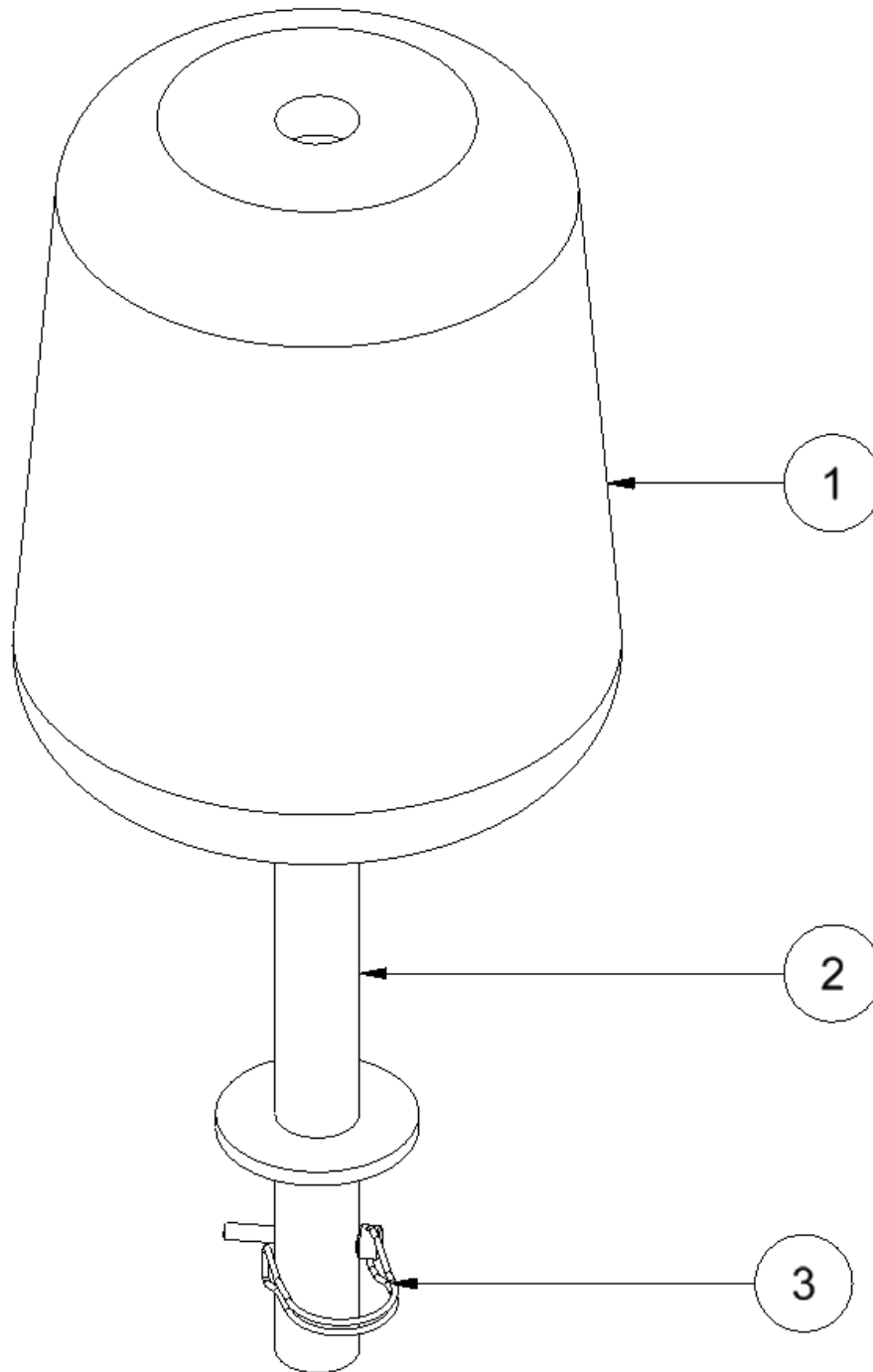

Optional Guide Roller

Item	Qty	Part #	Description
		TLGR	Guide Roller Kit
1	2	TL550-301-238	Roller
2	2	TL550-301-239	Spindle
3	2	TL550-301-233	Lock Pin



Guide Roller Location

Optional Twin Wrap Kit

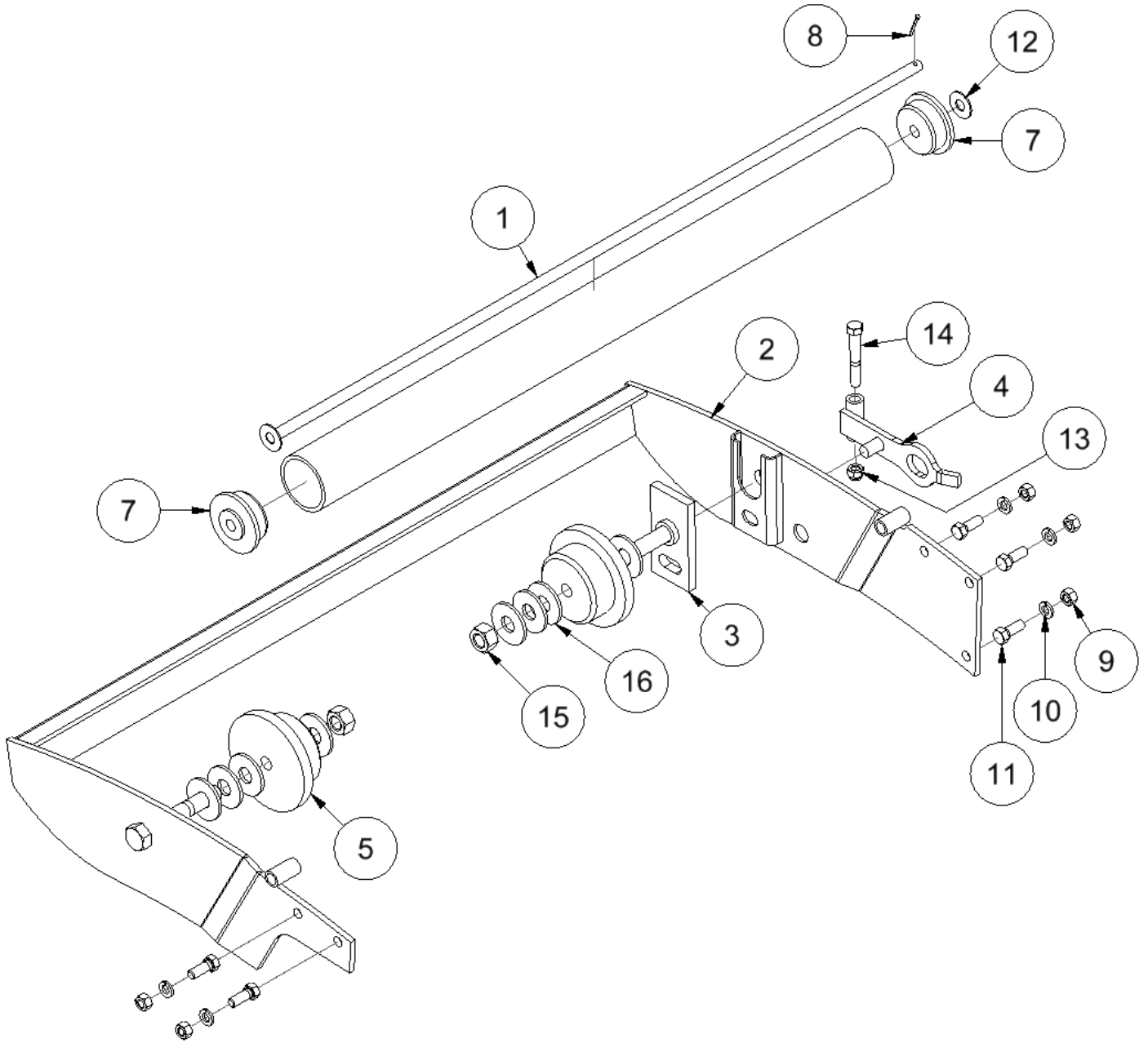

Optional Twin Wrap Kit

Item	Qty	Part #	Description
		TL TWK	Twin Wrap Kit
1	1	TL TWROD	Idler Axle
2	1	TL550-200-139	Twin Wrap Frame
3	1	TL550-200-115	Spool Holder Bracket
4	1	TL550-200-103	Spool Holder Latch
5	2	TL550-200-012	Wrap Spool Holder
6	1	TL550-100-022	Plastic Idler
7	2	TL 16P40D	Idler End Caps
8	1	Obtain Locally	1/8" Cotter Pin
9	5	Obtain Locally	HN 3/8" Hex Nut
10	5	Obtain Locally	LW 3/8" Lockwasher
11	5	Obtain Locally	HB 3/8" X 1" Hex Bolt
12	2	Obtain Locally	FW 7/16" Flatwasher
13	1	Obtain Locally	LN 3/8" Lock Nut UNC
14	1	Obtain Locally	HB 3/8" X 2 1/2" Hex Bolt
15	2	Obtain Locally	HN 5/8" Hex Nut UNC
16	8	Obtain Locally	FW 5/8" Flatwasher

Optional Quick Start Power Jack

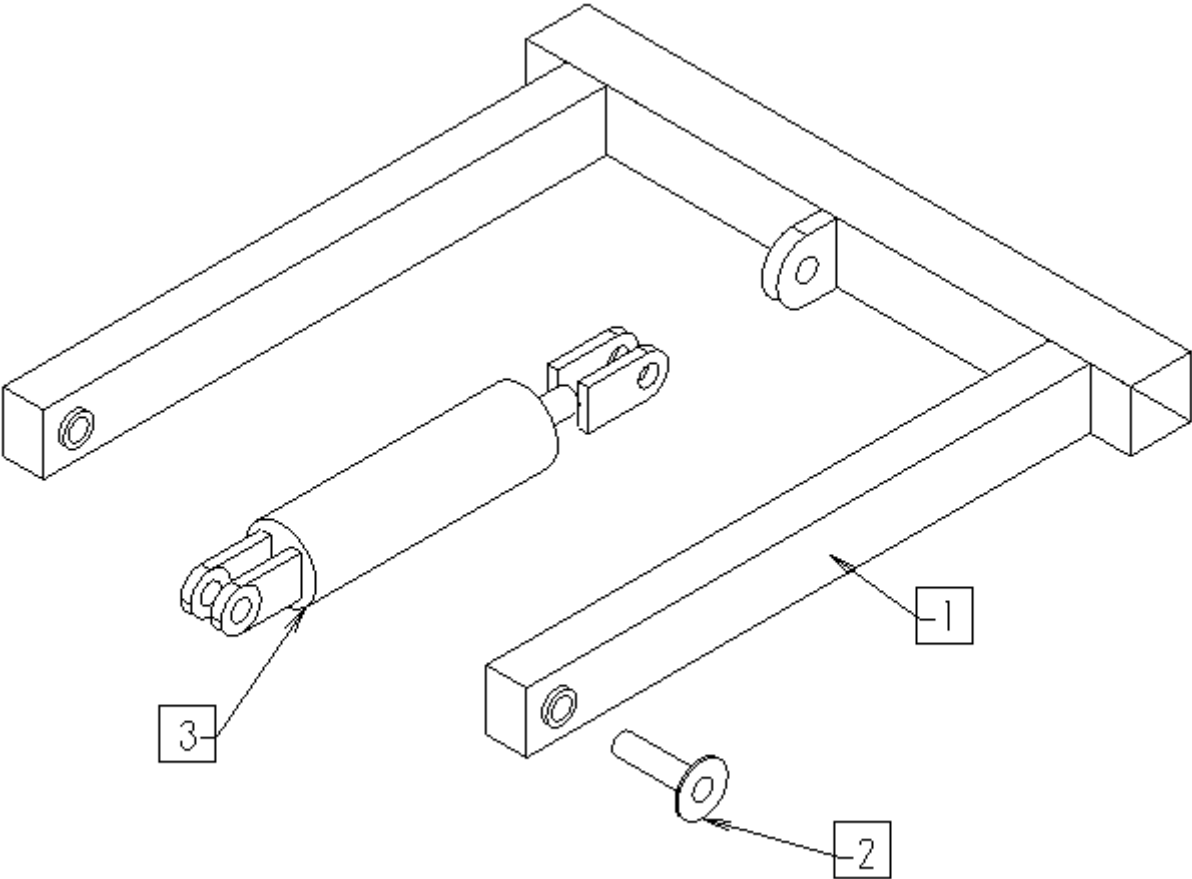

Optional Quick Start Power Jack

Item	Qty	Part #	Description
1	1	TL5X2-100-205	Main Stand
2	1	TL5X2-100-206	Pivot Pin
3	1	TL5X2-100-207	Cylinder

Dealer Installation

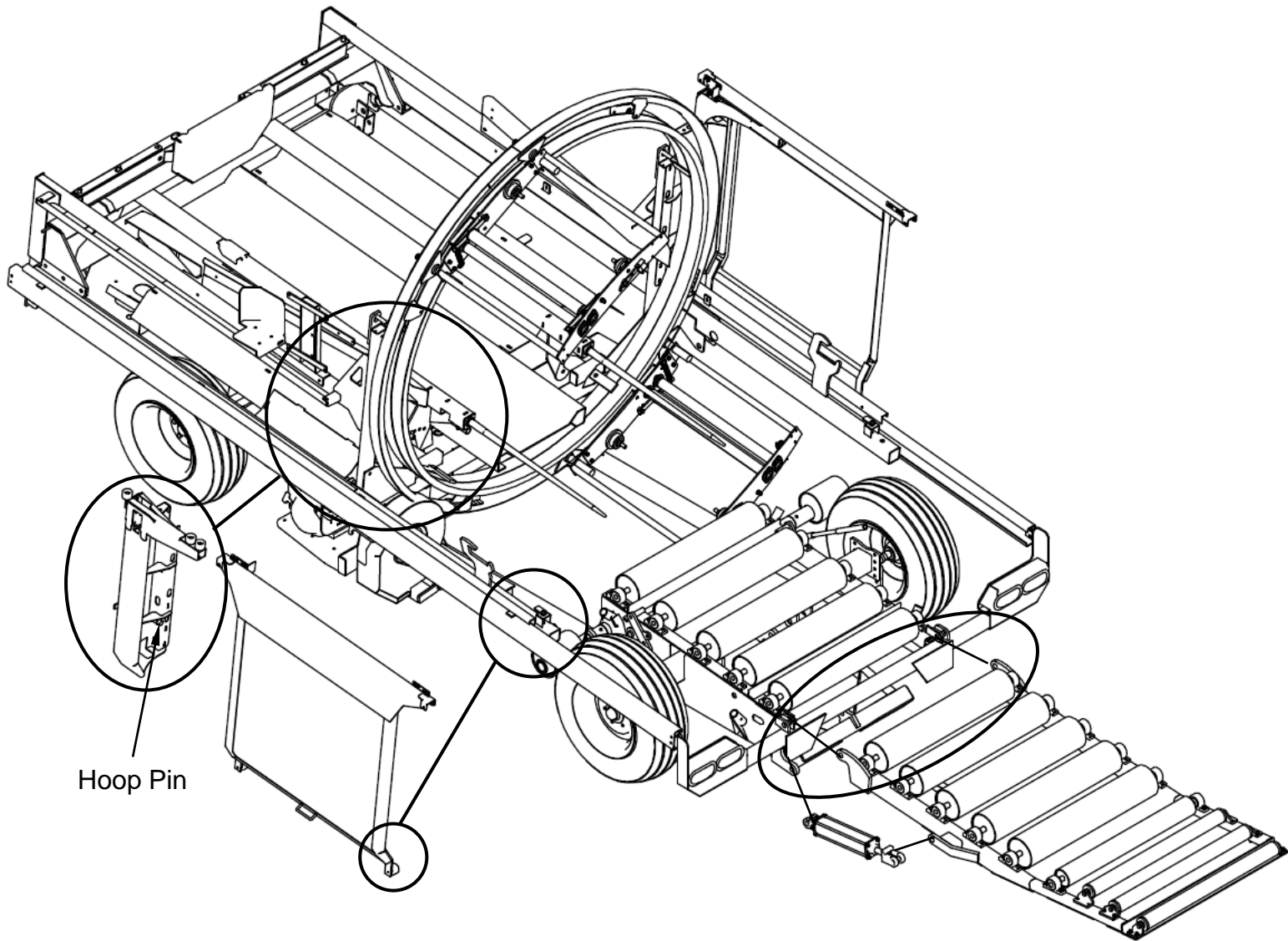











Hoop Pin

Dealer Installation

1. Remove the parts strapped to the roller bed, these include the doors, tail and door mounts
2. Remove the 5 loose bolts (3/8" x 1 1/4") on Hoop Brace, these will be used to attach the Door Mount
3. Move the Door Mount into position so that the bolts can be put back on but not fully tightened
4. Add the wheels attached to the Door Mount mesh to their proper position on top of the Door Mount
5. Remove the last bolt on the Door Track (towards back)
6. Slide the Doors into the Door Track, the top channel fits over the top wheel of the Door Mount. This keeps the door in line with the wheels in the Door Track
7. Refasten the last bolt on the Door Track, and fully tighten the Door Mount bolts.
8. NOTE : Use the slots in the Door Mounts to move it up or down. The wheels should be about a 1/4" from touching the top channel on the Doors. Be sure that the Hoop Lock pin can easily slide in and out of the Hoop Stop
9. Remove tail from roller bed by taking the lock nuts off the bolts. Insert the tail between the tabs and refasten nuts and bolts.
10. Next release the tie straps holding the upright cylinder. Use the pin and clips to secure it to the tail. Note : All hydraulics are ready to use on delivery.
11. Route wires for safety door switches
12. Adjust safety switches
13. Bolt red battery cable to battery
14. Start the Honda
15. To test the wrapper; switch to manual mode, jog the ram to speed up the engine. The hoop, power drive and steering can now be tested
16. If you ordered your machine with a steering remote and shut down kit you will find it in your control panel

UNIFIED INCH BOLT AND CAP SCREW TORQUE VALUES

SAE Grade and Head Markings	NO MARK	1 or 2 ^b 	5 	5.1 	5.2 	8 	8.2 	
SAE Grade and Nut Markings	NO MARK	2 	5 		8 		8 	

YS1162 -19-03M4R91

Size	Grade 1				Grade 2 ^b				Grade 5, 5.1, or 5.2				Grade 8 or 8.2			
	Lubricated ^a		Dry ^a		Lubricated ^a		Dry ^a		Lubricated ^a		Dry ^a		Lubricated ^a		Dry ^a	
	N·m	lb-ft	N·m	lb-ft	N·m	lb-ft	N·m	lb-ft	N·m	lb-ft	N·m	lb-ft	N·m	lb-ft	N·m	lb-ft
1/4	3.7	2.8	4.7	3.5	6	4.5	7.5	5.5	9.5	7	12	9	13.5	10	17	12.5
5/16	7.7	5.5	10	7	12	9	15	11	20	15	25	18	28	21	35	26
3/8	14	10	17	13	22	16	27	20	35	26	44	33	50	36	63	46
7/16	22	16	28	20	35	26	44	32	55	41	70	52	80	58	100	75
1/2	33	25	42	31	53	39	67	50	85	63	110	80	120	90	150	115
9/16	48	36	60	45	75	56	95	70	125	90	155	115	175	130	225	160
5/8	67	50	85	62	105	78	135	100	170	125	215	160	240	175	300	225
3/4	120	87	150	110	190	140	240	175	300	225	375	280	425	310	550	400
7/8	190	140	240	175	190	140	240	175	490	360	625	450	700	500	875	650
1	290	210	360	270	290	210	360	270	725	540	925	675	1050	750	1300	975
1-1/8	400	300	510	375	400	300	510	375	900	675	1150	850	1450	1075	1850	1350
1-1/4	570	425	725	530	570	425	725	530	1300	950	1650	1200	2050	1500	2600	1950
1-3/8	750	550	950	700	750	550	950	700	1700	1250	2150	1550	2700	2000	3400	2550
1-1/2	1000	725	1250	925	990	725	1250	930	2250	1650	2850	2100	3600	2650	4550	3350

DO NOT use these values if a different torque value or tightening procedure is given for a specific application. Torque values listed are for general use only. Check tightness of fasteners periodically.

Shear bolts are designed to fail under predetermined loads. Always replace shear bolts with identical grade.

^a "Lubricated" means coated with a lubricant such as engine oil, or fasteners with phosphate and oil coatings. "Dry" means plain or zinc plated without any lubrication.

^b Grade 2 applies for hex cap screws (not hex bolts) up to 152 mm (6-in.) long. Grade 1 applies for hex cap screws over 152 mm (6-in.) long, and for all other types of bolts and screws of any length.

Fasteners should be replaced with the same or higher grade. If higher grade fasteners are used, these should only be tightened to the strength of the original.

Make sure fasteners threads are clean and that you properly start thread engagement. This will prevent them from failing when tightening.

Tighten plastic insert or crimped steel-type lock nuts to approximately 50 percent of the dry torque shown in the chart, applied to the nut, not to the bolt head. Tighten toothed or serrated-type lock nuts to the full torque value.

METRIC BOLT AND CAP SCREW TORQUE VALUES

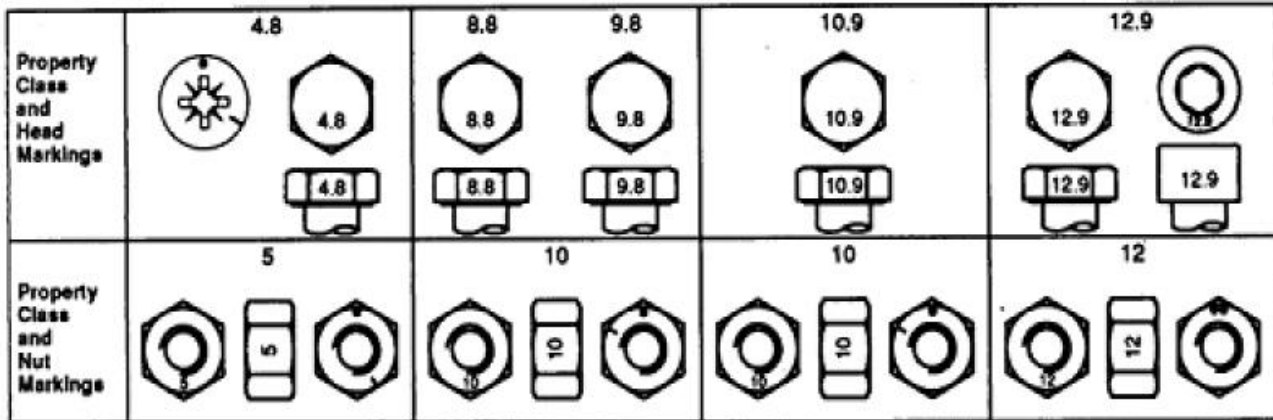

T81153 -19-0MM5R91

Size	Class 4.8				Class 8.8 or 9.8				Class 10.9				Class 12.9			
	Lubricated ^a		Dry ^a		Lubricated ^a		Dry ^a		Lubricated ^a		Dry ^a		Lubricated ^a		Dry ^a	
	N-m	lb-ft	N-m	lb-ft	N-m	lb-ft	N-m	lb-ft	N-m	lb-ft	N-m	lb-ft	N-m	lb-ft	N-m	lb-ft
M6	4.8	3.5	6	4.5	9	6.5	11	8.5	13	9.5	17	12	15	11.5	19	14.5
M8	12	8.5	15	11	22	16	28	20	32	24	40	30	37	28	47	35
M10	23	17	29	21	43	32	55	40	63	47	80	60	75	55	95	70
M12	40	29	50	37	75	55	95	70	110	80	140	105	130	95	165	120
M14	63	47	80	60	120	88	150	110	175	130	225	165	205	150	260	190
M16	100	73	125	92	190	140	240	175	275	200	350	255	320	240	400	300
M18	135	100	175	125	260	195	330	250	375	275	475	350	440	325	560	410
M20	190	140	240	180	375	275	475	350	530	400	675	500	625	460	800	580
M22	260	190	330	250	510	375	650	475	725	540	925	675	850	625	1075	800
M24	330	250	425	310	650	475	825	600	925	675	1150	850	1075	800	1350	1000
M27	490	360	625	450	950	700	1200	875	1350	1000	1700	1250	1600	1150	2000	1500
M30	675	490	850	625	1300	950	1650	1200	1850	1350	2300	1700	2150	1600	2700	2000
M33	900	675	1150	850	1750	1300	2200	1650	2500	1850	3150	2350	2900	2150	3700	2750
M36	1150	850	1450	1075	2250	1650	2850	2100	3200	2350	4050	3000	3750	2750	4750	3500

DO NOT use these values if a different torque value or tightening procedure is given for a specific application. Torque values listed are for general use only. Check tightness of fasteners periodically.

Shear bolts are designed to fail under predetermined loads. Always replace shear bolts with identical property class.

Fasteners should be replaced with the same or higher property class. If higher property class fasteners are used, these should only be tightened to the strength of the original.

^a "Lubricated" means coated with a lubricant such as engine oil, or fasteners with phosphate and oil coatings. "Dry" means plain or zinc plated without any lubrication.

Make sure fasteners threads are clean and that you properly start thread engagement. This will prevent them from failing when tightening.

Tighten plastic insert or crimped steel-type lock nuts to approximately 50 percent of the dry torque shown in the chart, applied to the nut, not to the bolt head. Tighten toothed or serrated-type lock nuts to the full torque value.

TUBE•LINE™
MANUFACTURING LTD.