

TUBE•LINE™

Tubeline Manufacturing Limited
6455 Reid Woods Drive RR #4
Elmira, Ontario, Canada N3B 2Z3

Email: sales@tubeline.ca

Fax: 519.669.5808

Tel: 519.669.9488

Toll-free (North America): 1.888.856.6613

www.tubeline.ca

Parts Manual

Keep this manual with the machine at all times.

ACCUMUL 8 Retriever

Bale Retriever

TLG10R

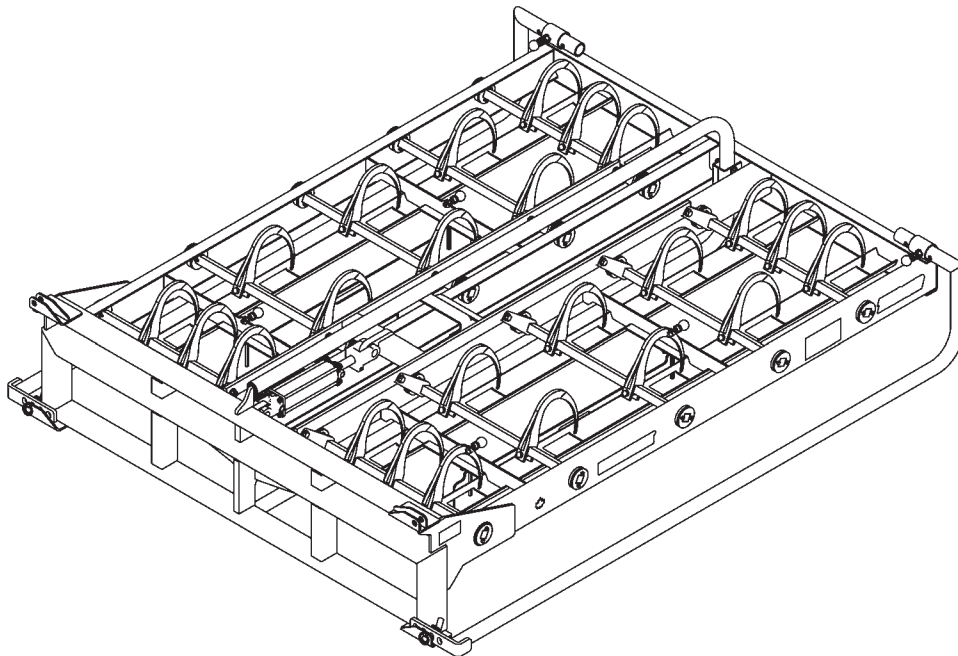

Do not attempt to operate this machine without thoroughly reviewing this manual for safe and proper operation.

Parts Manual

Thank you for choosing the Tubeline Bale Retriever. We know that it will give you many years of productive service. This front mounted machine is designed to gather small square bales into a large pack for easy transportation and storage.

Parts Manual Usage

This parts manual is used to order replacement parts by means of part breakdowns and their corresponding part lists. Each page contains a different range of integrated parts. Each illustration visually represents machine components. The part lists contain information needed to order replacement parts. Part lists include the following columns:

ITEM - Number matching parts breakdown balloons.

QTY - Quantity of components included in this breakdown, not entire machine.

PART NUMBER - The number to be used when placing an order.

DESCRIPTION - Term used to confirm its matching part number.

NOTE - Column may be added to part lists when a serial break or additional information is required.

Remember to always have your machine model and serial number on hand when ordering parts.

Part Orders

Part orders are taken by your local Tubeline dealer and fulfilled through a regional distributor. For quick service please record your dealer name and contact information in the [Serial Number](#) section.

Manuals

Parts manuals are printed and shipped with machines as they leave the manufacturer. Your machine may include parts or features not yet included in the initially shipped manual. The latest manual version can be found at www.tubeline.ca/support. Tubeline reserves the right to update and change manuals as seen fit. Dealers are informed of any pressing changes/ modifications. They can help you with any questions regarding replacement parts and proper operating procedures.

Serial Number

The implement serial number is located on the upper rear right corner of the frame. This number helps us to track changes and improvements and must be mentioned when ordering parts or requesting service. For your convenience, a space has been provided inside the front cover of this manual to record the serial number, model number, purchase date, and dealer name.

Model No: _____ TLG10R

Serial No: _____

Date Purchased: _____

Dealer Name: _____

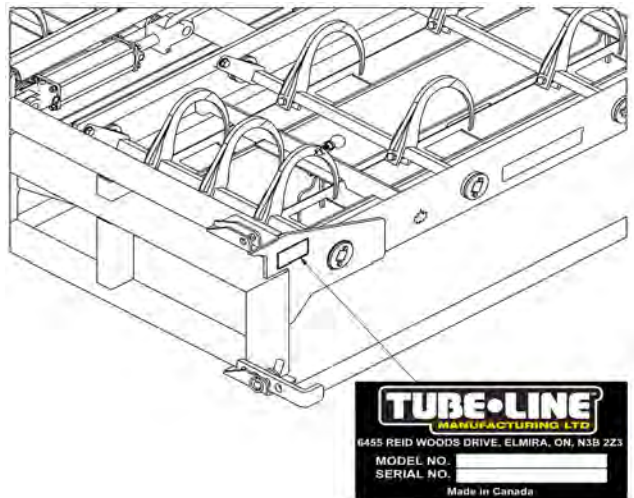

Warranty and Limitation of Liability

All equipment is sold subject to mutual agreement that it is warranted by the company to be free from defects of materials and workmanship. But the company shall not be liable for special, indirect or consequential, damages of any kind under this contract or otherwise. The company's liability shall be limited exclusively to replacing or repairing without charge, at its factory or elsewhere, at its discretion.

Any material, or workmanship defects which become apparent within one year from the date on which the equipment was purchased, and the company shall have no liability for damages of any kind. The buyer by the acceptance of the equipment will assume all liability for any damages, which may result from the use or misuse by his employees or others.

Table of Contents

Parts Manual	II
Parts Manual Usage	II
Part Orders	II
Manuals	II
Serial Number	II
Warranty and Limitation of Liability	III
Section 1 - Specifications	1-1
Dimensions	1-1
Terminology	1-2
Orientation	1-3
Bale Sizes	1-3
Section 2 - Parts Breakdowns & Lists	2-1
Decal Locations	2-2
Decals	2-3
Bale Guides	2-4
Bale Hooks	2-5
Torque Value Chart - Imperial	VII
Torque Value Chart - Metric	VIII

Intentionally Left Blank

Section 1 - Parts Breakdowns & Lists

Decal Locations

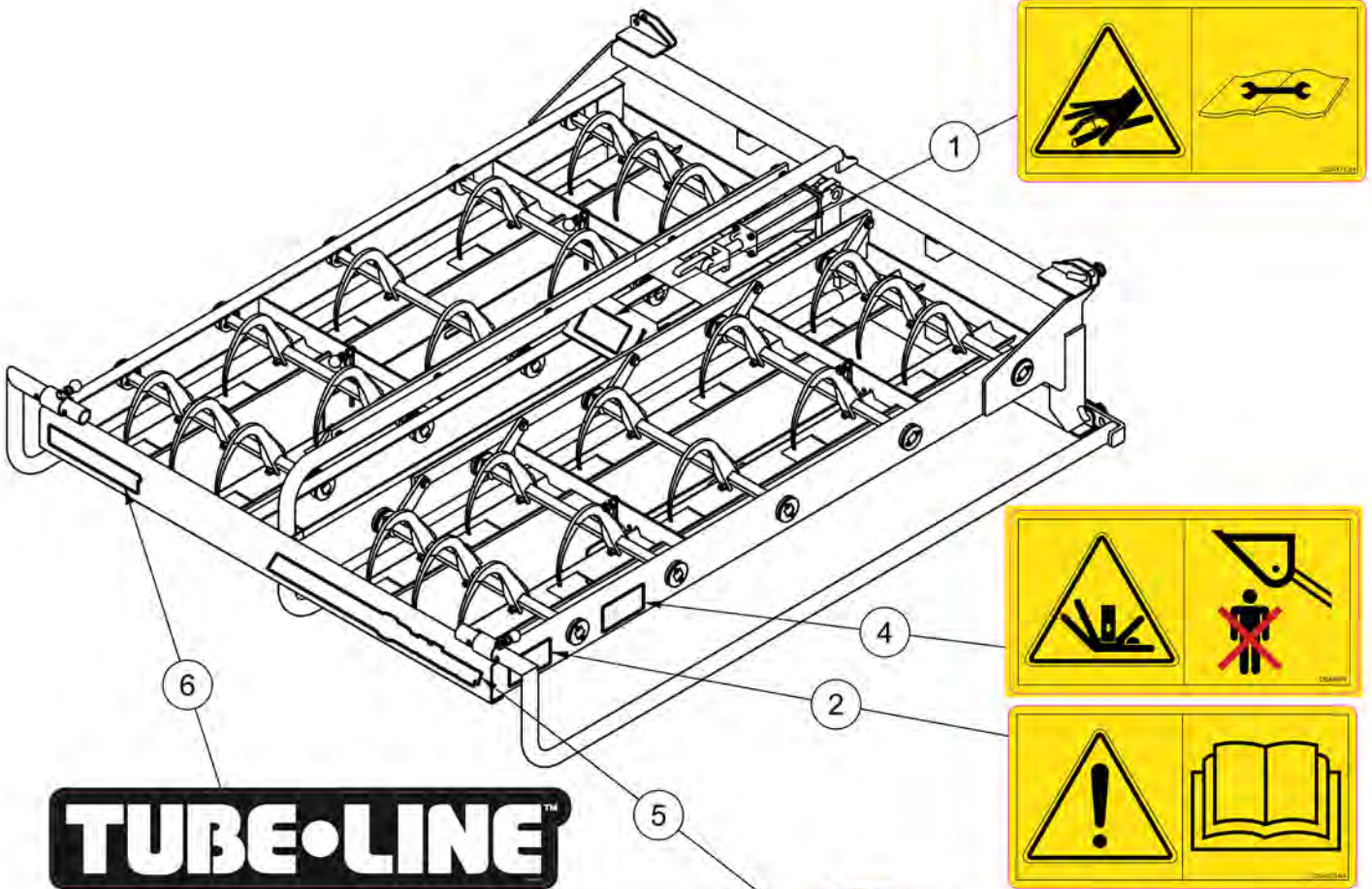

TUBE•LINE™

ACCUMUL8 Retriever

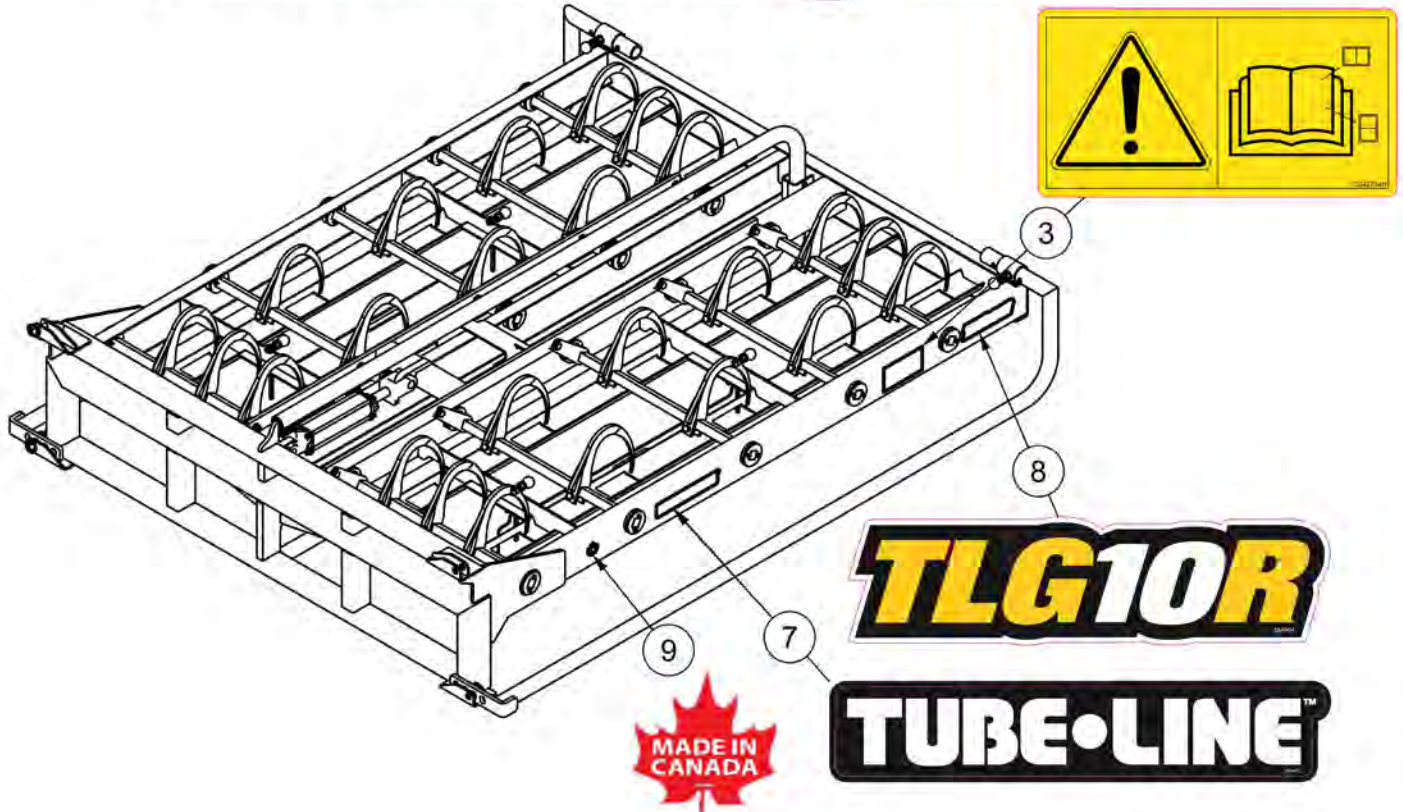

TLG10R

TUBE•LINE™



Decals

ITEM	QTY	PART NUMBER	DESCRIPTION
1	1	DE41713H	ISO Decal - High Pressure Fluid Horizontal
2	1	DE41714H	ISO Decal - Read OM Horizontal
3	1	DE42784H	ISO Decal - Read OM Decal Section Horizontal
4	1	DE46097	ISO Decal - Crush from Above
5	1	DE49411	Accumul8 Retriever Model Decal
6	1	DE49412	Tubeline Decal 14.6in x 2.7in
7	1	DE49413	Tubeline Decal 10.8in x 2in
8	1	DE49414	TLGR10R Model Decal
9	1	DECANADA	Decal Made In Canada

Part No: DE41713H Item: 1

Do not use hand to check for hydraulic leaks, alternatively use a piece of cardboard.



Part No: DE41714H Item: 2

Read this manual and learn the machine functions before attempting to operate it.



Part No: DE42784H Item: 3

Read Operator's manual decal section to understand safety decals.



Part No: DE46097 Item: 4

Read Operator's manual decal section to understand safety decals.



ACCUMUL8 Retriever

Part No: DE49411 Item: 5

Model decal.

TUBE•LINE™

Part No: DE49412,

DE49413

Item: 6,7



TLG10R

Part No: DE9414

Item: 8

Part No: DECANADA Item: 9

Manufacturer's country of origin.

Bale Guides

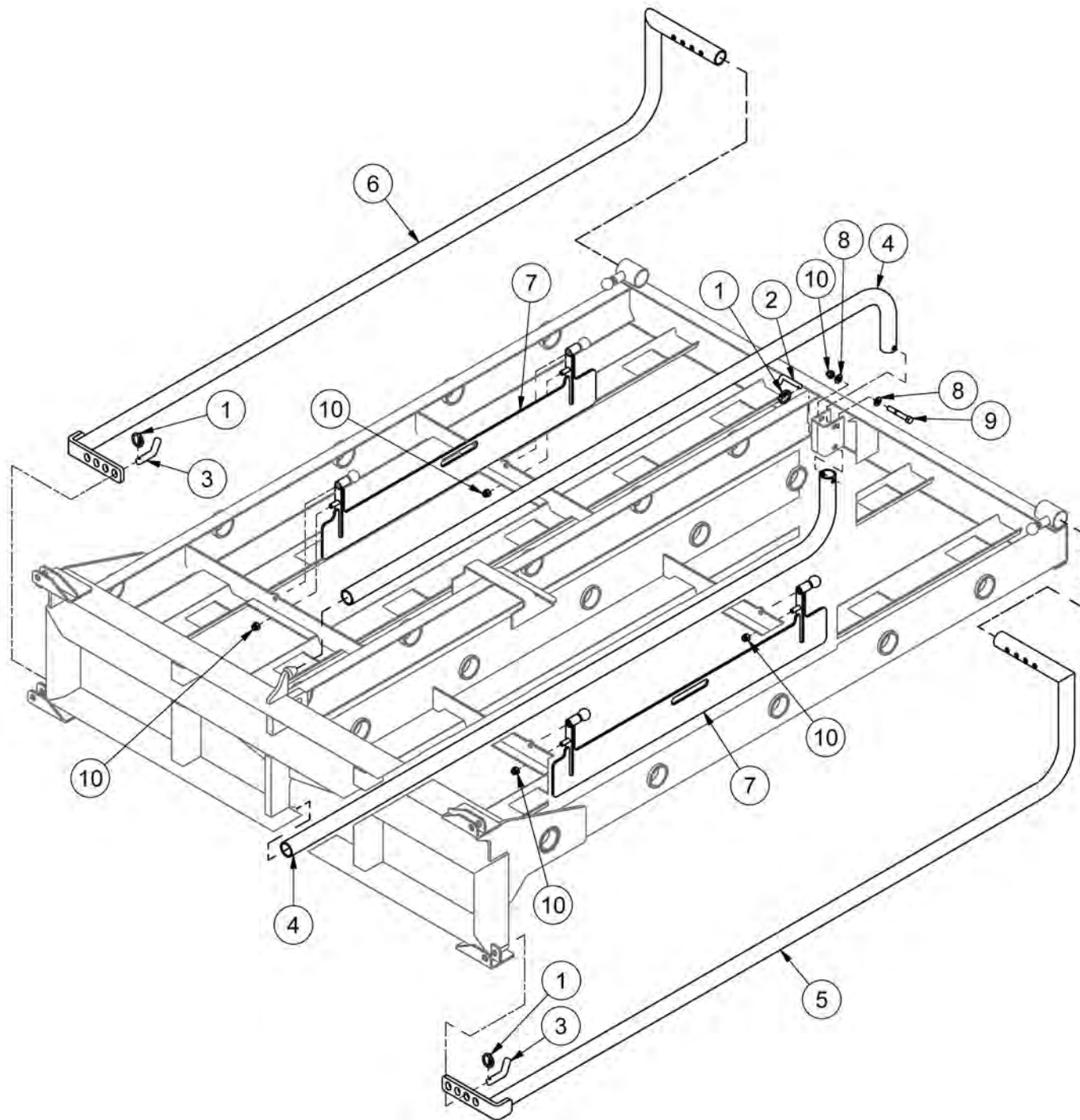





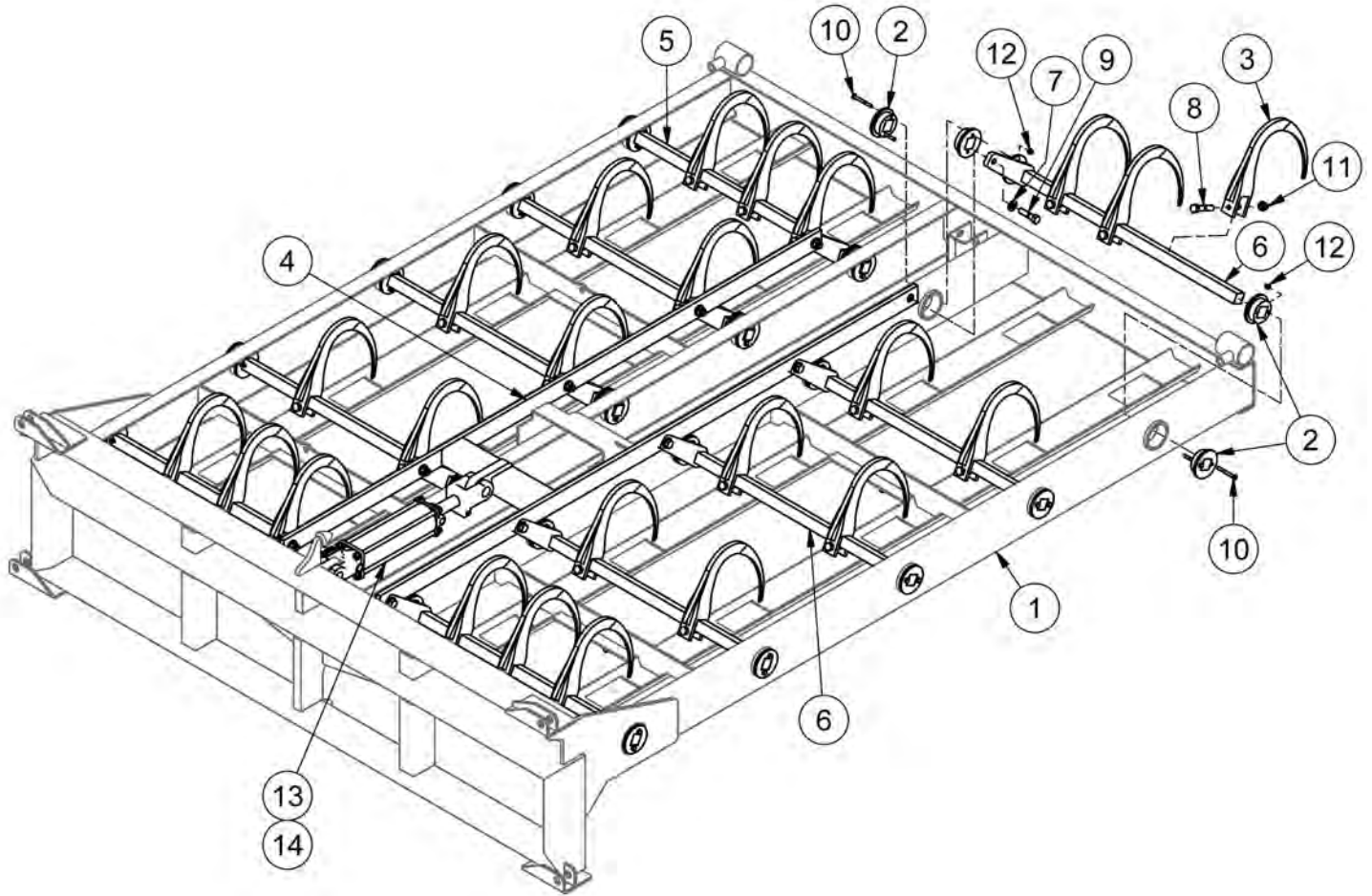



ITEM	QTY	PART NUMBER	DESCRIPTION
1	3	25680	Linch Pin 3/16 X 1.5
2	1	80244	Pin
3	2	80245	Side Pin
4	2	80271	Center Guide
5	1	80272	Right Bale Guide
6	1	80276	Left Bale Guide
7	2	80278	Inside Guide
8	2	FW 1/2	Flatwasher - 1/2" Zinc Plated USS
9	1	HB1/2-13X3.25Z5	Hex Bolt 1/2-13x3 1/4 Grade 5 Zinc Plated Hex Cap Screw
10	5	LN1/2-13NCZ5	LN 1/2-13 Zinc Plated Nylon Insert Lock Nut

Bale Hooks

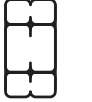
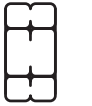

ITEM	QTY	PART NUMBER	DESCRIPTION
1	1	80248	Frame
2	40	AC-0006G-004	UV Resistant UHMW Bushing
3	24	AC-0006G-005	Hook
4	1	AC-1006G-02	Cylinder Mount
5	5	AC-1006G-AG-03	Left Grabber Pivot
6	5	AC-1006G-AG-04	Right Grabber Pivot
7	20	FW 1/2	Flatwasher - 1/2" Zinc Plated USS
8	24	HB1/2-13X2.5Z5	Hex Bolt 1/2-13x2 1/2 Grade 5 Zinc Plated Hex Cap Screw
9	10	HB1/2-13X2Z5	Hex Bolt 1/2-13x2 Grade 5 Zinc Plated Hex Cap Screw
10	40	HB1/4-20X2.25Z5	Hex Bolt 1/4-20x2 1/4 Grade 5 Zinc Plated Hex Cap Screw
11	38	LN1/2-13NCZ5	LN 1/2-13 Zinc Plated Nylon Insert Lock Nut
12	39	LN1/4-20NCZ5	LN 1/4-20 Zinc Plated Nylon Insert Lock Nut
13	1	TL500-100-082	HYS 25AGU08-ASAE-10
14	1	SK AGU251125-10	Seal Kit for 25 Series Cylinder

Torque Value Chart - Imperial

SAE Grade and Head Markings	1 or 2 ^b	5	5.1	5.2	8	8.2
	NO MARK					
SAE Grade and Nut Markings	2	5		8		
	NO MARK					

Size	Grade 1				Grade 2 ^b				Grade 5, 5.1, or 5.2				Grade 8 or 8.2			
	Lubricated ^a		Dry ^a		Lubricated ^a		Dry ^a		Lubricated ^a		Dry ^a		Lubricated ^a		Dry ^a	
	N-m	lb-ft	N-m	lb-ft	N-m	lb-ft	N-m	lb-ft	N-m	lb-ft	N-m	lb-ft	N-m	lb-ft	N-m	lb-ft
1/4	3.7	2.8	4.7	3.5	6	4.5	7.5	5.5	9.5	7	12	9	13.5	10	17	12.5
5/16	7.7	5.5	10	7	12	9	15	11	20	15	25	18	28	21	35	26
3/8	14	10	17	13	22	16	27	20	35	26	44	33	50	36	63	46
7/16	22	16	28	20	35	26	44	32	55	41	70	52	80	58	100	75
1/2	33	25	42	31	53	39	67	50	85	63	110	80	120	90	150	115
9/16	48	36	60	45	75	56	95	70	125	90	155	115	175	130	225	160
5/8	67	50	85	62	105	78	135	100	170	125	215	160	240	175	300	225
3/4	120	87	150	110	190	140	240	175	300	225	375	280	425	310	550	400
7/8	190	140	240	175	190	140	240	175	490	360	625	450	700	500	875	650
1	290	210	360	270	290	210	360	270	725	540	925	675	1050	750	1300	975
1-1/8	400	300	510	375	400	300	510	375	900	675	1150	850	1450	1075	1850	1350
1-1/4	570	425	725	530	570	425	725	530	1300	950	1650	1200	2050	1500	2600	1950
1-3/8	750	550	950	700	750	550	950	700	1700	1250	2150	1550	2700	2000	3400	2550
1-1/2	1000	725	1250	925	990	725	1250	930	2250	1650	2850	2100	3600	2650	4550	3350

DO NOT use these values if a different torque value or tightening procedure is given for a specific application. Torque values listed are for general use only. Check tightness of fasteners periodically.

Shear bolts are designed to fail under predetermined loads. Always replace shear bolts with identical grade.

Fasteners should be replaced with the same or higher grade. If higher grade fasteners are used, these should only be tightened to the strength of the original.

Make sure fasteners threads are clean and that you properly start thread engagement. This will prevent them from failing when tightening.

Tighten plastic insert or crimped steel-type lock nuts to approximately 50 percent of the dry torque shown in the chart, applied to the nut, not to the bolt head. Tighten toothed or serrated-type lock nuts to the full torque value.

^a "Lubricated" means coated with a lubricant such as engine oil, or fasteners with phosphate and oil coatings. "Dry" means plain or zinc plated without any lubrication.

^b Grade 2 applies for hex cap screws (not hex bolts) up to 152 mm (6-in.) long. Grade 1 applies for hex cap screws over 152 mm (6-in.) long, and for all other types of bolts and screws of any length.

Torque Value Chart - Metric

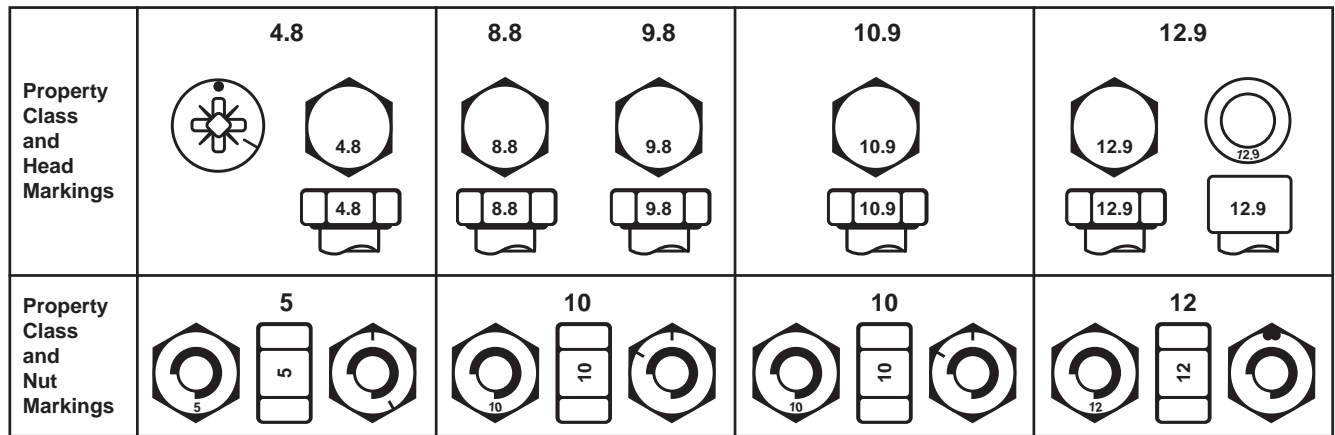

Size	Class 4.8				Class 8.8 or 9.8				Class 10.9				Class 12.9			
	Lubricated ^a		Dry ^a		Lubricated ^a		Dry ^a		Lubricated ^a		Dry ^a		Lubricated ^a		Dry ^a	
	N-m	lb-ft	N-m	lb-ft	N-m	lb-ft	N-m	lb-ft	N-m	lb-ft	N-m	lb-ft	N-m	lb-ft	N-m	lb-ft
M6	4.8	3.5	6	4.5	9	6.5	11	8.5	13	9.5	17	12	15	11.5	19	14.5
M8	12	8.5	15	11	22	16	28	20	32	24	40	30	37	28	47	35
M10	23	17	29	21	43	32	55	40	63	47	80	60	75	55	95	70
M12	40	29	50	37	75	55	95	70	110	80	140	105	130	95	165	120
M14	63	47	80	60	120	88	150	110	175	130	225	165	205	150	260	190
M16	100	73	125	92	190	140	240	175	275	200	350	255	320	240	400	300
M18	135	100	175	125	260	195	330	250	375	275	475	350	440	325	560	410
M20	190	140	240	180	375	275	475	350	530	400	675	500	625	460	800	580
M22	260	190	330	250	510	375	650	475	725	540	925	675	850	625	1075	800
M24	330	250	425	310	650	475	825	600	925	675	1150	850	1075	800	1350	1000
M27	490	360	625	450	950	700	1200	875	1350	1000	1700	1250	1600	1150	2000	1500
M30	675	490	850	625	1300	950	1650	1200	1850	1350	2300	1700	2150	1600	2700	2000
M33	900	675	1150	850	1750	1300	2200	1650	2500	1850	3150	2350	2900	2150	3700	2750
M36	1150	850	1450	1075	2250	1650	2850	2100	3200	2350	4050	3000	3750	2750	4750	3500

DO NOT use these values if a different torque value or tightening procedure is given for a specific application. Torque values listed are for general use only. Check tightness of fasteners periodically.

Shear bolts are designed to fail under predetermined loads. Always replace shear bolts with identical property class.

Fasteners should be replaced with the same or higher property class. If higher property class fasteners are used, these should only be tightened to the strength of the original.

Make sure fasteners threads are clean and that you properly start thread engagement. This will prevent them from failing when tightening.

Tighten plastic insert or crimped steel-type lock nuts to approximately 50 percent of the dry torque shown in the chart, applied to the nut, not to the bolt head. Tighten toothed or serrated-type lock nuts to the full torque value.

^a "Lubricated" means coated with a lubricant such as engine oil, or fasteners with phosphate and oil coatings. "Dry" means plain or zinc plated without any lubrication.

Index

Bale Guides1-4
Bale Hooks.1-5
Decal Locations1-2
Decals1-3
Manuals	II
Part Orders	II
Parts Manual	II
Parts Manual Usage	II
Section 1 - Parts Breakdowns & Lists1-1
Serial Number.	II
Torque Value Chart - ImperialVII
Torque Value Chart - MetricVIII
Warranty and Limitation of Liability	III

TUBE•LINE™