



## **ML280 LOADER**

**OPERATOR'S & PARTS MANUAL**

**TUBELINE MANUFACTURING / FREY INDUSTRIES**

**3928 Steffler Rd. Elmira, Ontario N3B 2Z3**

**Telephone: (519) 664-0488 Fax: (519) 664-0492**

**Toll Free (888) 856-6613**

**Email: [sales@freyindustries.com](mailto:sales@freyindustries.com)**

# Contents

Page	a	Table of Contents
Page	b	Decals
Page	b(I)	Decals continued
Page	b(ii)	Safety
Page	b(iii)	Safety (a)
Page	c	Introductory Letter
Page	d	Owner Records
Page	e	Do's & Don'ts
Page	f	Warranty
Page	g	Installation Instructions
Page	h	Loader Operation
Page	ii	Service
Page	j	Service
Page	1	Loader Parts Guide
Page	2	Parts
Page	3	Hydraulics
Page	4	SD5 Valve
Page	4a	Bondioli Valve
Page	5	SD5 Valve Linkage Breakdown
Page	6	Joystick & Cable Connections
Page	7	Lubrication / Maintenance
Page	8	Notice

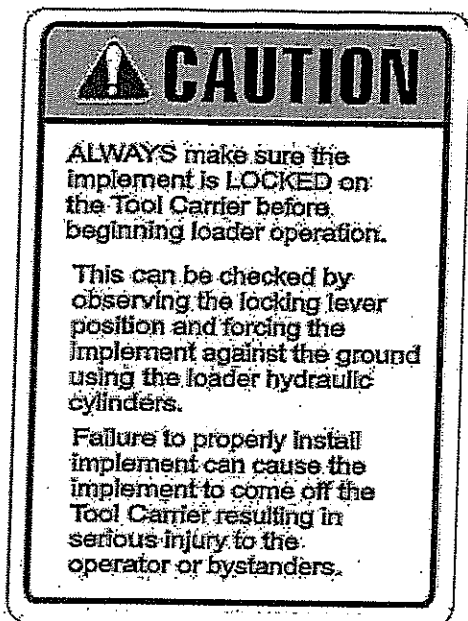

**DE23584**  
 Caution Decal [make sure attachments are secure]

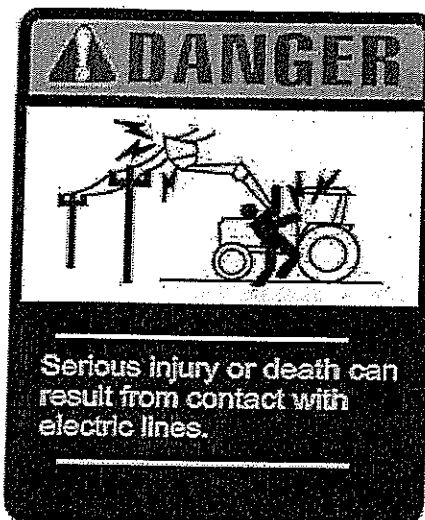

**DE23581**  
 Danger Decal [High voltage lines]

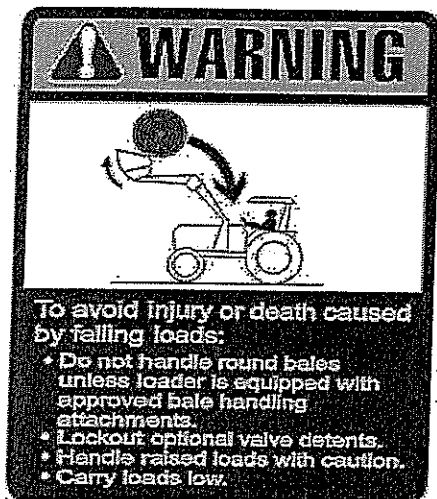

**DE23579**  
 Warning Decal [Bale roll down arms]



**DE23583**  
 Warning Decal [Do not ride in bucket]

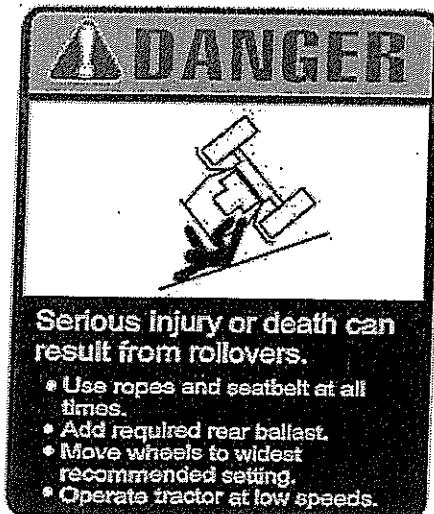

**DE23580**  
 Danger Decal [Tractor Roll over]



**DE23582**  
 Warning Decal [Under loader danger]



**DECANADA**

**! CAUTION**

Be sure to purge all the air from the hydraulic system before attempting to raise or lower this machine. Refer to owner's manual for further details.

**DE22581**

**! CAUTION**

1. Read operator's manual (especially safety precautions) before operating this machine.
2. Move and turn tractor at low speeds.
3. Carry loader arms at a low position during transport.
4. Lower arms, stop engine, relieve all hydraulic pressure, and lock brakes before leaving operator's seat.
5. Add recommended wheel ballast or rear weight for stability.
6. Move wheels to widest recommended settings to increase stability.
7. A roll-over protective structure is recommended for a tractor equipped with a loader.
8. Before disconnecting hydraulic lines, relieve hydraulic pressure.
9. Escaping hydraulic oil under pressure can have sufficient force to penetrate the skin, causing serious personal injury. If injured by escaping fluid, obtain medical treatment immediately.
10. Do not use loader for handling large, loose or shiftable loads which might fall out of the bucket or roll down the loader arms onto the operator.
11. Make sure loader and attachments are properly secured before operating.

**DE21703**

## ***Driving on Public Roads***

While driving tractor and loader, follow these precautions:

- Carry loads close to the ground to aid visibility and to lower center of gravity.
- Allow for additional length of loader on tractor while turning.
- Balance loads so weight is evenly distributed and load is stable.
- Drive slowly if carrying materials. Rough conditions may cause material to spill.
- Avoid carrying materials wider than the bucket/attachment or tractor.

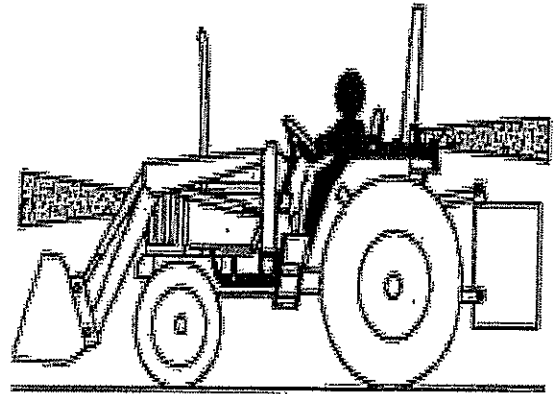

---

## ***Service Loader Safely***

Always engage parking brake or place transmission in Park, lower loader to the ground, shut off engine and remove key before servicing the loader.

Do not walk or perform service under a raised loader, bucket or attachment unless it is securely blocked or held in position.

Keep all parts in good condition and properly installed. Repair any damage immediately and repair or replace any worn or broken parts.

Before disconnecting hydraulic hoses, relieve all hydraulic pressure.

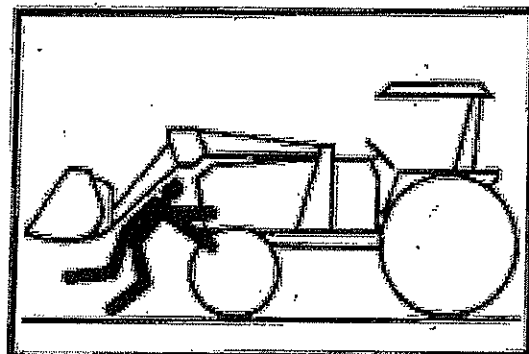
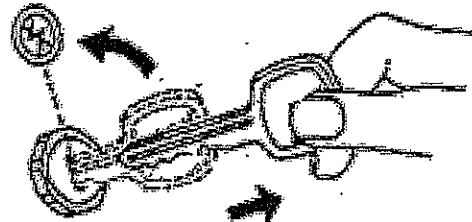

## ***Recognize Safety Information***

This is a safety-alert symbol. When you see this symbol on your machine or in this manual, be alert to the potential for personal injury.

Follow recommended precautions and safe operating practices.

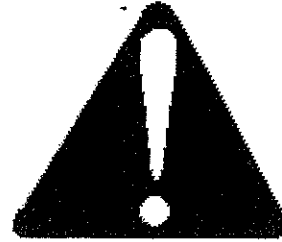

---

## ***Understand Signal Words***

A signal word – DANGER, WARNING, or CAUTION- is used with the safety-alert symbol. DANGER identifies the most serious hazards.

---

**▲ DANGER**

**▲ WARNING**

**▲ CAUTION**

---

## ***Follow Safety Instructions***

Carefully read all safety messages in the manual and on your loader safety signs. Keep safety signs in good condition. Replace missing or damaged safety signs. Be sure new equipment components and repair parts include the current safety signs. Replacement safety signs are available.

Learn how to operate the loader and how to use the controls properly. Do not let anyone operate without instruction.

Keep your loader in proper working condition. Unauthorized modifications to the loader may impair the function and/or safety and affect loader life.

If you do not understand any part of this manual and need assistance, contact Frey Industries.

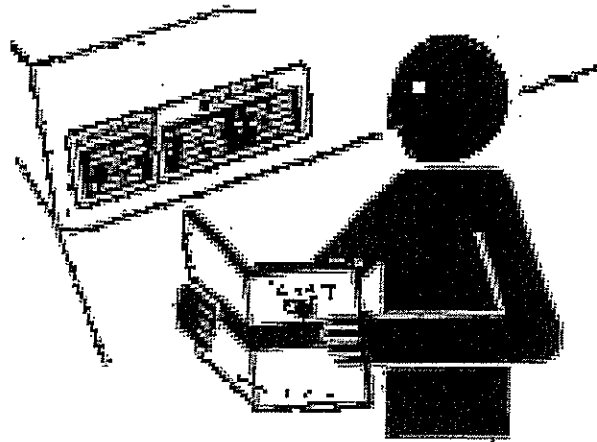

Dear Customer:

Congratulations in purchasing the finest loader manufactured. Our loader will provide you with many years of service, but as with any product, proper operation and service must be maintained to insure its longevity. This manual contains all the pertinent information needed to operate and maintain your loader.

The FREY ML280 Loader is designed to fit agricultural tractors in the 35 to 45 HP range and are specifically designed to be used in agricultural and livestock businesses. The Loader has been manufactured to be user friendly as far as operating, mounting and dismounting.

It is very important that you take the time to read and familiarize yourself with this manual. Be sure that you have signed the loader WARRANTY REGISTRATION card and your dealer has sent it to our office for registration.

We at FREY Sincerely appreciate your business and our commitment is to customer satisfaction. Please contact your dealer or our customer service unit with any question about our loaders or any of our other products.

Thank You

Frey Industries Ltd.

# OWNER RECORDS

Model:

Serial No:

Date Purchased:

Dealer:

---

---

---

---



**DO'S**

1. Read this manual before operating the loader. It is important to become familiar with and follow all recommended safety precautions.
2. Rollover protection is recommended for your tractor while operating the loader.
3. Follow all mounting and operating instructions carefully.
4. Move the wheels to the widest adjustment and add rear weight to insure maximum stability.
5. Lower the loader to the lowest position, stop the engine, relieve the hydraulic system pressure and set the tractor brakes before leaving the operator's seat.
6. When the tractor is in motion, keep the loader in a lower position. This will insure that your vision will not be hampered.
7. Be sure to slow down when making turns with your tractor to prevent accidentally hitting objects with your loader arms.
8. Before disconnecting the hydraulic hoses, release any hydraulic pressure from the system to prevent serious injury from rapidly escaping pressurized oil.
9. Adjust your tractor speed when the loader is carrying a load according to the conditions and terrain.
10. If you are operating the loader with a hydraulic valve, always be sure to use smooth motions when operating the lever (s) to prevent jerking of the loader and always be sure the lever (s) return to their neutral position. **Never Assume Anything!!!**

**DO NOT'S**

1. Do not hesitate to contact your dealer for assistance in mounting and operation of your loader.
2. Do not make drastic movements with the tractor or loader.
3. Do not continue operation if tractor balance is affected.
4. Do not exceed loader specifications.
5. Do not use loader for moving large, shiftable or loose loads that are not properly secured to the attachment. This will prevent the load from falling off or rolling down the loader boom arms.
6. Do not use the loader for lifting or carrying people for any reason.
7. Do not stand, walk or work under a raised loader under any condition.
8. Do not use the loader for backgrading. This improper use of the loader puts extreme stress on the latching device, which could cause it to fail.
9. Do not run the loader into a mound of material at a rapid speed. This kind of action could cause serious damage to your loader or tractor or it could result in a serious injury.
10. Do not strictly use the lift arms for lifting the load. The tilt cylinders should be used to assist you in lifting your load.
11. **Very Important!!!** Never operate the loader without the safety pins installed on the main loader frame and attachments. Failure to do so could cause the loader or attachments to come unattached from the mounting frame.

**Failure to comply with the above DO'S and DO NOT'S may result in equipment failure and / or personally injury!**

## WARRANTY

Frey Industries Ltd. warrants each item of farm equipment distributed by FREY, to be free from defects from material and workmanship under reasonable use and service. The obligation of the Company under this warranty is limited to the repairing, the replacing or the refunding of the purchase price, less reasonable depreciation, as the Company may elect, for part or parts which shall be returned to a Distributor or Dealer of the Company with transportation charges prepaid by the purchaser, and as to which examination shall disclose to the Company's satisfaction to have been defective in material or workmanship, provided that such part or parts shall be reported to the Dealer or Distributor as being defective not later than twelve months from the date of the first use by the original purchaser. This warranty does not obligate FREY to bear the cost of labour in replacement of such defective parts.

This warranty shall not apply to equipment which has been altered, improperly maintained, or repaired so as in the Company's judgment, to have adversely affected its performance. The Company makes no warranty of any character with respect to electric motors, belts, hydraulic hoses, valves, cylinders, or other items not manufactured by the Company.

The Company's warranty and its obligation hereunder is in lieu of all other warranties, including without limitation, IMPLIED WARRANTIES OF MERCHANTABILITY AND FITNESS FOR A PARTICULAR PURPOSE and all other representations to the Distributor, Dealer and original purchaser, that extend beyond the description of the equipment. The Company shall not be liable for incidental and consequential damages or either of them of any nature whether based on tort or contract. No person is authorized to give warranties or to assume any liabilities unless made in writing by an authorized representative of FREY.

## COMPLETE AND RETURN WARRANTY CARDS

# INSTALLATION INSTRUCTIONS

## Models ML280 Loader

- Operation #1 -- Mounting Sideframes
- Operation #2 -- Loader Preparation
- Operation #3 -- Mounting Loader for Model ML280
- Operation #4 -- Mounting Attachments

### Operation #1 -- Mounting Sideframes

#### STEPS --

1. Take L.H. sideframes to L.H. side of tractor.
2. Using hoist, raise sideframe up to side of tractor aligning bolt holes in tractor to frame.
3. Take appropriate bolts and start threading them into tractor (do not tighten).
4. If axle brackets are required, at this point assemble but do not tighten bolts.
5. After all bolts have been started, return and tighten all bolts securely.

-- Repeat process for R.H. side

### Operation #2 -- Loader Preparation

1. Mount valve on R.H. loader post.
2. With hoses supplied in bag kit, assemble them from valve to loader as shown in figures #2.
3. Dealer should cut the 1/2" hose to length from the valve to the tractor making sure hose is long enough to reach valve when loader is removed.
4. Hook pressure hose to in-port on valve. Hook suction hose to out-port on valve.

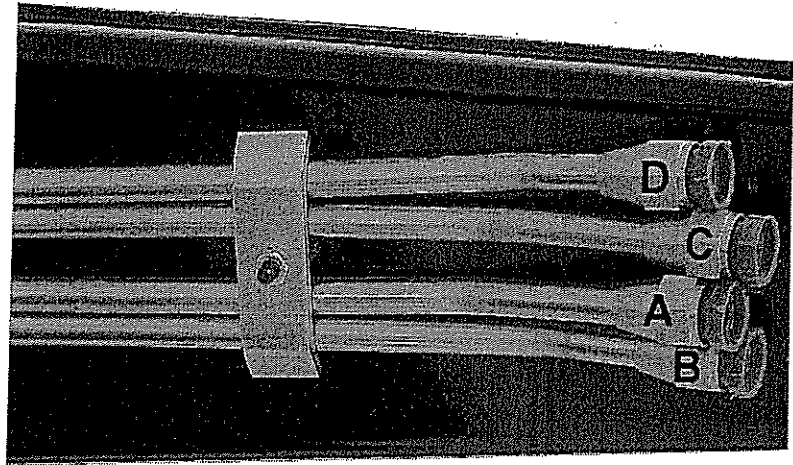
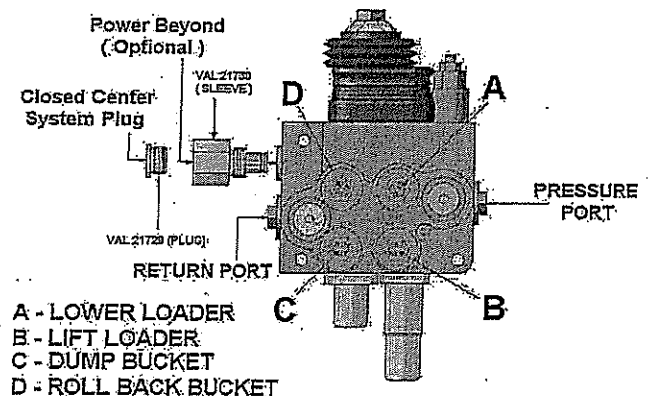

Figure 1



The Ports on the Valve connect to the corresponding lines on the loader. For example, port A on the Valve connects to line A on the Loader

If the loader is equipped with a Bondioli Valve refer to Page 4a for port configuration.

## Loader Operation/Maintenance

1. Once the hydraulics have been hooked up, you must bleed the air from the hydraulic system before operation. Leaving air in the system could be very dangerous because it greatly affects the performance of the loader. Loosen the hyd. fittings on the lower cylinders and activate the tractor remote or auxiliary valve until clean, uncontaminated oil flows out. The loader will go up and down smoothly without jerking and there should be no unusual noises coming from the hydraulic system. Always be sure that all connections have been properly tightened.
2. After completion of Item 1 above, recheck all mounting frame bolts for proper torque. Initial operation can cause loosening of the fasteners. Please double check again after the first hour of operation and again after 10 hours of operation.
3. Our loader can be used in many different functions and will perform up to expectations, however, the loader **has not** been designed to be used in any type of digging and we highly recommend you refrain from this activity. **The loader warranty does not cover damage that occurs as a result of misuse.**
4. There are two primary positions for the loader; the neutral position and the working position.

When the loader is in the neutral position, there is no hydraulic oil movement in any of the loader's cylinders. If you are using the tractor remotes, the loader will remain in neutral until you open the remote by moving the remote lever on the tractor. If you are using an additional hydraulic valve the oil will pass through the valve and back to the tank until the lever on the valve is actuated and then the oil will travel to the lift or bucket cylinders. The loader is in the working position when you open the tractor remote or auxiliary valve by pushing or pulling the lever. This allows the oil to travel to the cylinders that activates their movement in either lifting or tilting function.



5. The hydraulics can be hooked up to your tractor in many different ways. This is usually decided at the dealership where you purchased the loader. We recommend that you familiarize yourself on how your dealer hooked up your hydraulics. This can help us in the future if you are needing to check your system for hydraulic leaks or any other unseen problem. If you have purchased an auxiliary valve to operate your loader, be sure that you allow the hydraulic oil to warm up before operating the loader. If the hydraulic fluid has not warmed up, its viscosity will be too low; it will not move properly and could damage the hydraulic lines. After the hydraulic oil has reached its operating temperature, always limit the number of times you open and close your valve. By repeatedly opening and closing the valve you could experience overheating of your tractor hydraulic system.

## SERVICE

1. Check your tractor's hydraulic oil often and check the hydraulic fittings for any looseness that may occur after prolonged use.
2. If the control valve is making noise, it will need to be adjusted.
3. All grease points should be greased regularly especially if you use the loader often.
4. Please change the oil in the loader every 500 hours if it's being used in heavy work conditions, 800 hours if in normal working conditions and 1100 hours if being used in light applications.
5. If your loader is needing major service we highly recommend that you take it to your closest Frey dealer for repairs.
6. Frey will only honor warranties performed by qualified technicians approved by our company.
7. Replacement parts can be obtained at your nearest authorized Frey dealer.
8. **(VERY IMPORTANT)** When ordering parts it is essential that you give the model of your loader, serial number, date of purchase, what kind of tractor it is mounted on and the part number required. (Refer to the parts catalog at the back of the manual to find the part number you need.)
9. **NEVER** use any attachments that are not specifically designed for our loader. Doing so will void your warranty.

<b>PROBLEM</b>	<b><u>TROUBLESHOOTING</u></b>	<b>SOLUTION</b>
	<b>REASON</b>	
Oil leaking	Loose hyd. fittings Loose fittings Damaged gaskets Damaged pipelines Damaged couplers	Tighten hyd. Fittings Tighten fittings Repair gaskets Repair pipes Repair couplers
Loader jerks and makes noise	Not enough oil in system Vibration in pressure lines Air in loader system Dirty oil Water in the oil	Add oil Secure the lines Bleed the air out Change oil Change oil
Movement of the loader lift cylinder is uncontrolled	Air in cylinder Damaged seals Deformed seals Pressure isolation	Bleed the hydraulic system Change seals Change cylinder Control & change isolation



**Metric Bolt Torque Values**

		
Bolt Size	Class 8.8 lb-in	Class 10.9 lb-in
M6	79	115
M8	194	24
M10	32	46
M12	55	80
M14	88	130
M16	140	200
M18	195	275
M20	275	390
M22	375	535
M24	480	680

Torque values listed are for general use only based on the strength of the bolt. Do Not use these values if a different torque value or tightening procedure is given for a specific application.

Replace fasteners with the same or higher grade. If higher grade fasteners are used, tighten these to the strength of the original. Make sure fastener threads are clean and that you properly start thread engagement.

**Imperial Bolt Torque Values**

		
Bolt Size	SAE Grade 5 lb-ft	SAE Grade 8 lb-ft
1/4	5	9
5/16	10	20
3/8	26	36
7/16	41	59
1/2	63	88
9/16	92	130
5/8	125	175
3/4	220	315
7/8	360	510
1	540	760
1 1/8	670	1075
1 1/4	945	1500
1 3/8	1250	2000
1 1/2	1650	2650

Torque values listed are for general use only based on the strength of the bolt. Do Not use these values if a different torque value or tightening procedure is given for a specific application.

Replace fasteners with the same or higher grade. If higher grade fasteners are used, tighten these to the strength of the original. Make sure fastener threads are clean and that you properly start thread engagement.

LOADER  
ILLUSTRATIONS  
&  
PARTS  
GUIDE

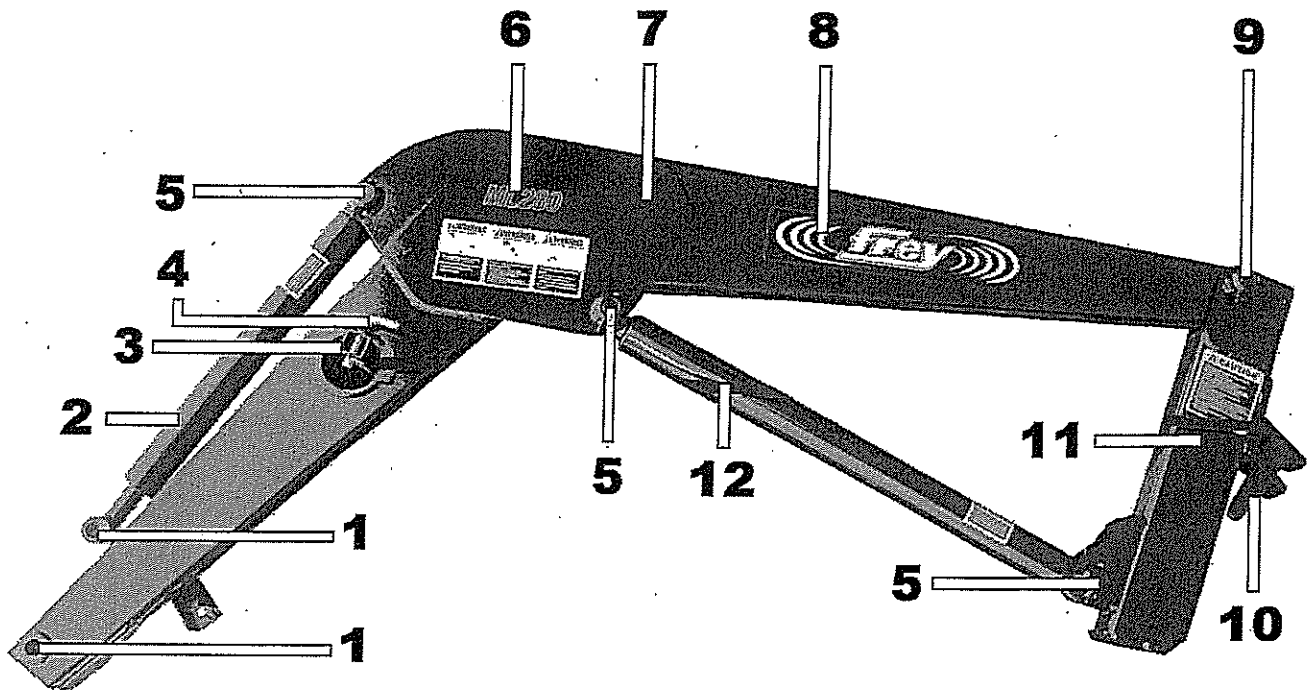

ITEM	Part Number	Description	QTY
1	21114	Pin 1" x 6" Tapered	4
2	P03-003	Cylinder, ML280, Bucket, 2.25 X 16	2
3	21850	Leg For ML280	2
4	21447	Pin Standard Lock Model 180,190,280,460	2
5	21035	Pin 5.0 Hinge	6
6	DE280	Decal ML280	2
7	21002	Assembly Model 280 Loader Boom Arm	1
8	DEFREY	Decal Frey loader logo	2
9	21036	Pin 1" x 5 1/2"	2
10	21423	Wedge, Large	2
11	21003	Post Model 280 Loader	2
12	P03-004	Cylinder, ML280, Lift, 2.25 x 26	2
13	P85-001S	Seal Kit 2 1/4" (Not Shown)	4



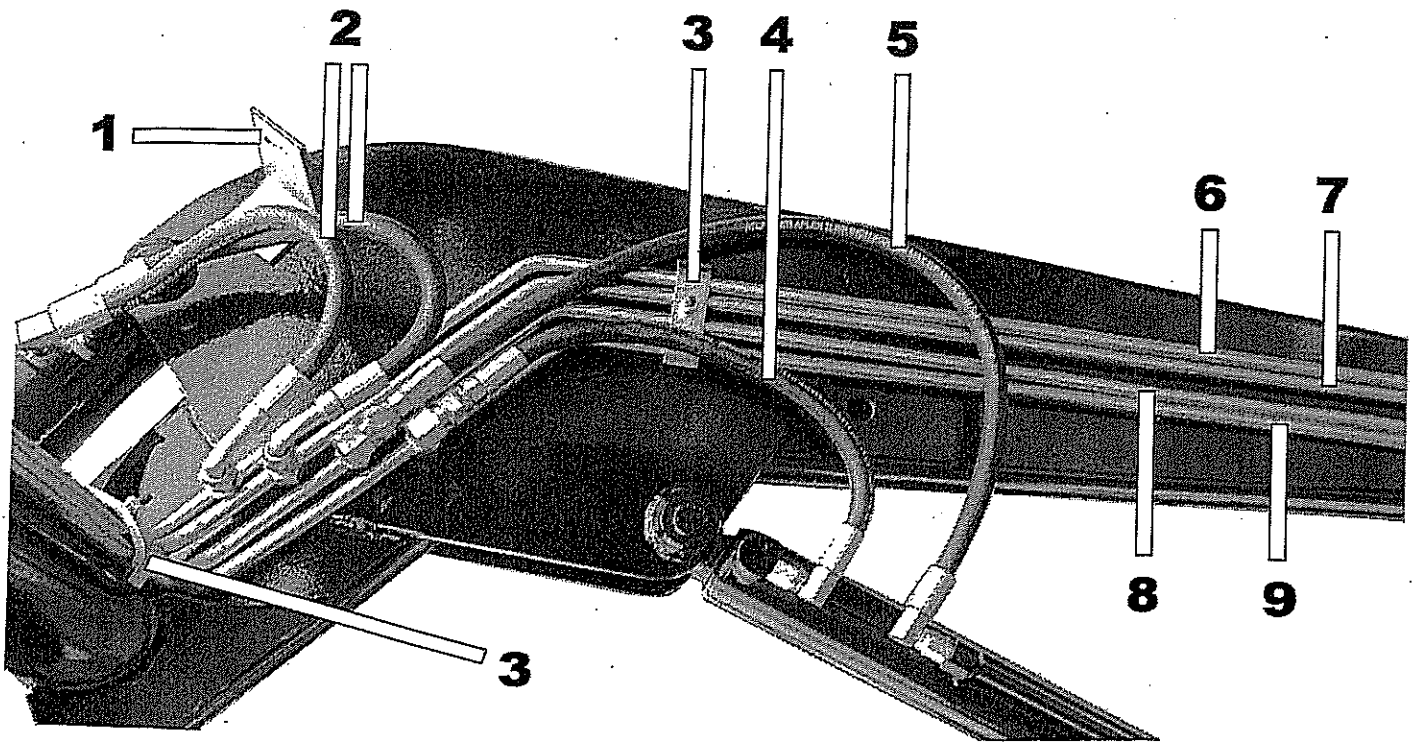

ITEM	Part Number	Description	QTY
1	22677	Bracket For Bucket Level Indicator	1
2	22692	6AT1[8FJX90S,6MBX90] HCL 16"	4
3	22789	Oil line Clip (with ends bent in)	2
3	21357	Oil Line Clip	2
4	22924	6AT1[6MBX90,8FJXH] HCL 15"	2
5	22691	6AT1[8FJX,6MB] E/E 32"	2
6	22687	Hyd. Tube, ML280, Top Line	1
7	22688	Hyd. Tube, ML280, 2nd Line Down.	1
8	22689	Hyd. Tube, ML280, 3rd Line Down	1
9	22690	Hyd. Tube, ML280, Bottom Line	1

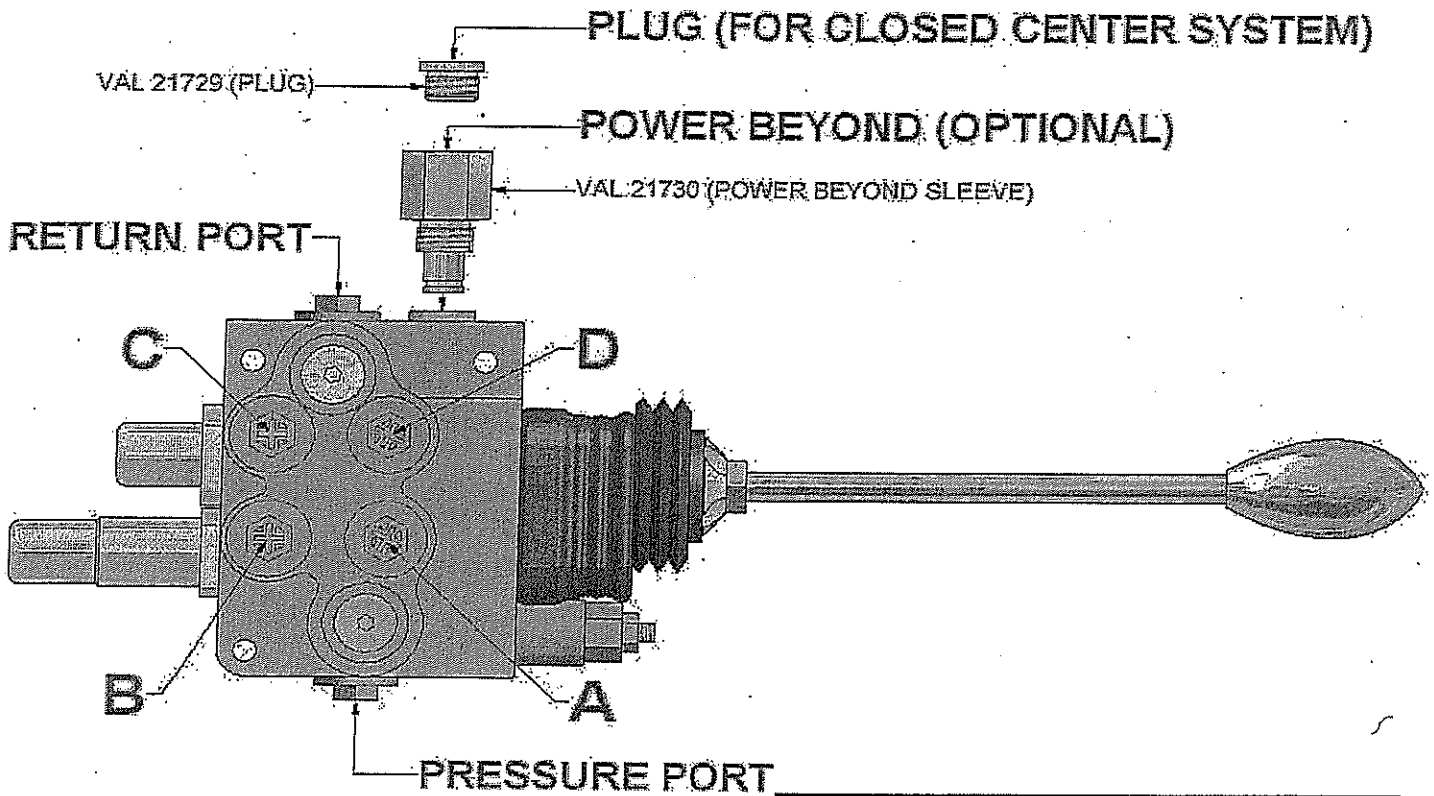

- A - LOWER LOADER
- B - LIFT LOADER
- C - DUMP BUCKET
- D - ROLL BACK BUCKET

<b>Part No.</b>
<b>Ports Up: ML1006-LCB3</b>
<b>Ports Down: ML1006-LCB1</b>
<b>Description: SD5 Valve</b>

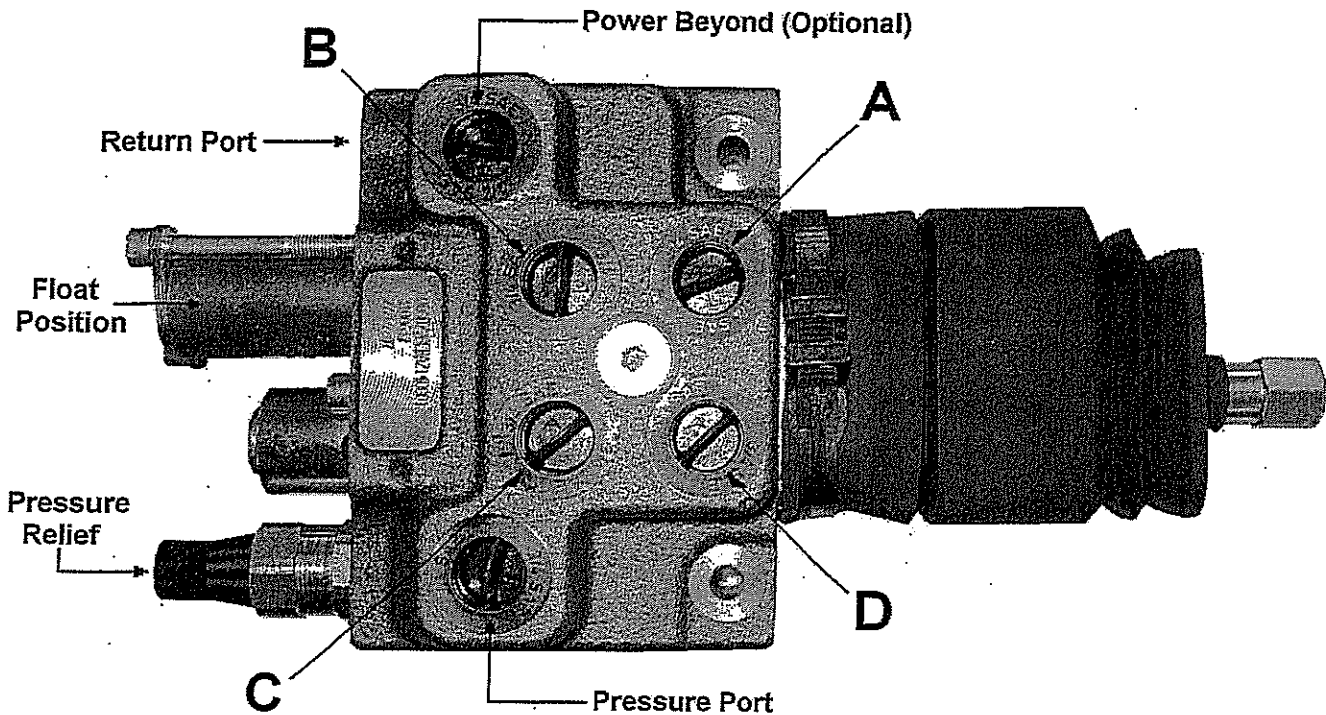

- A - LOWER LOADER
- B - LIFT LOADER
- C - DUMP BUCKET
- D - ROLL BACK BUCKET

**Part No. ML1006-LCB3DN**  
**Description: Bondioli**

Part Number	Description
ML1006-LCB3DN	Bondioli Valve
VAL DN2-D034	Carry Over Fitting
58045NS03	Float Detent Kit
580660A02	Short End Cap
55513621	Kit, Ball Joint (Boot) actuator
535118012	Joystick Lever

**Warning:** Your New Valve Has a Float Position Identified by the Longer Spring Mechanism Opposite the Joystick or Joystick Cable Connections. Your Loader Lift Cylinder Hoses Must be installed Such That When You Push the Joystick Forward, The Loader Goes into its Down Cycle. The Float Position is Activated When The Joystick is Pushed Fully forward. **Do Not !!** Install the Hoses Where The Lift Cycle is Activated by Pushing the Joystick Forward!

# SD5 VALVE

## LCB 5 - 5CL0205000

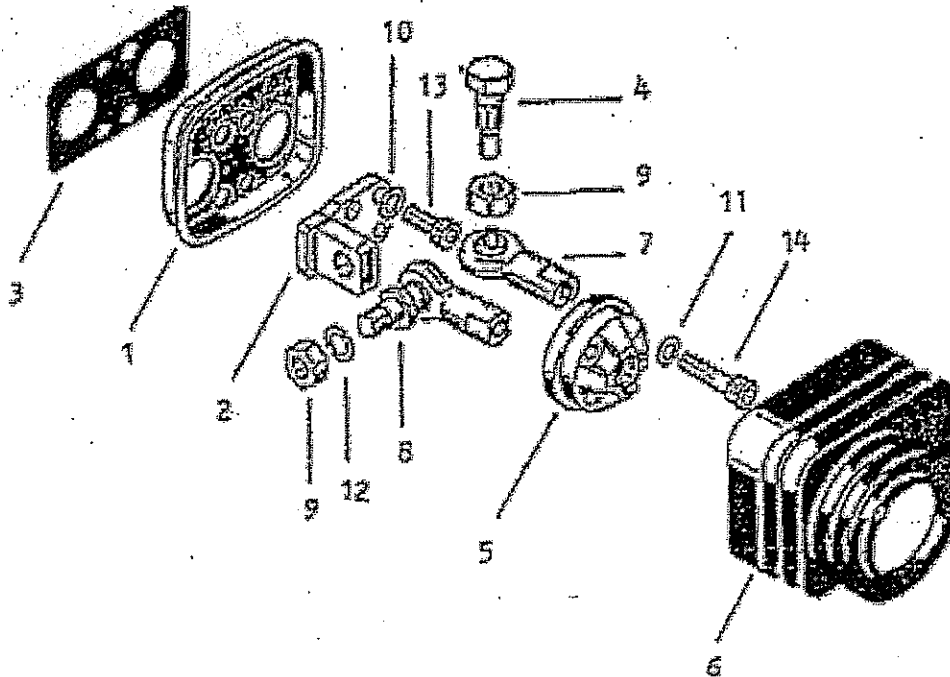

Item No.	Part No.	Description	Alternate #	Qty.
1	3FLA125100	Flange		1
2	3FUL220000	Fulcrum		1
3	3GUA167050	Seal		1
4	3PER513340	Pin	21869	1
5	3POR340240	Articulation roller	21870	1
6	3SOF200590	Rubber bellow	21868	1
7	4ART006000	Tuthill	21867	1
8	4ART106000	Connecting rod	21866	2
9	4DAD208125	M8 nut		3
10	4ROS305312	5,3x8,9x1,2 washer		4
11	4ROS606407	6,4x13x0,8 washer		3
12	4ROS608408	8,4x13x0,8 washer		2
13	4VIT605014	Screw M5x14		4
14	4VIT606025	Screw M6x25		3

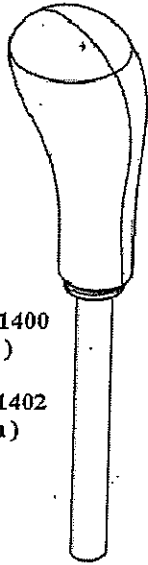

VAL XAST481400  
(No Switch)

VAL XAST481402  
(With Switch)

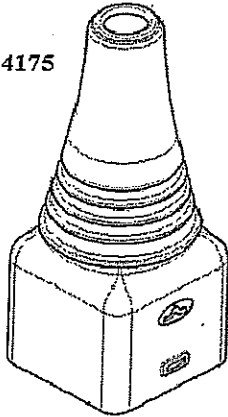

VAL 3SOF204175



VAL 4DAD314150



VAL 3FUL845130

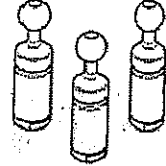

VAL 3PER314610

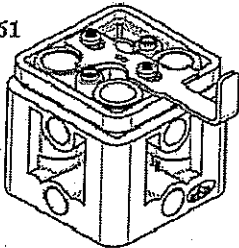

VAL XCOR211761

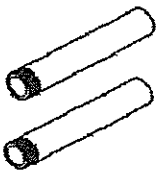

VAL 3ANE112151

VAL 4ROS606407

VAL 4VIT606020

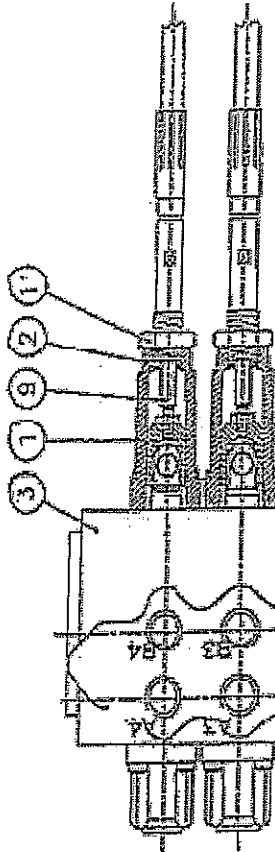
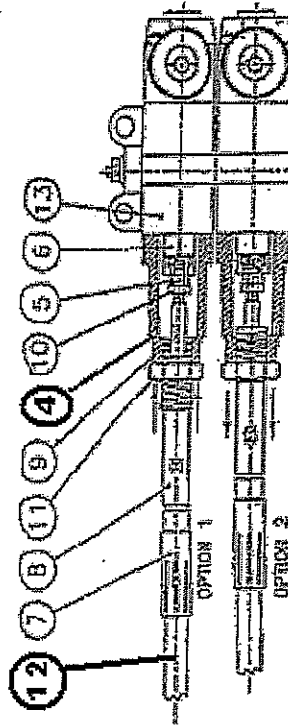

SD5 - PART # VAL 22045  
SD11 - PART # VAL 22044

CONNECTOR KIT

1.5m CABLE - PART # VAL 22048

4

12

**First 10 Hours**

- Lubricate fittings on each side of loader.
- Tighten mounting frame hardware on both sides.

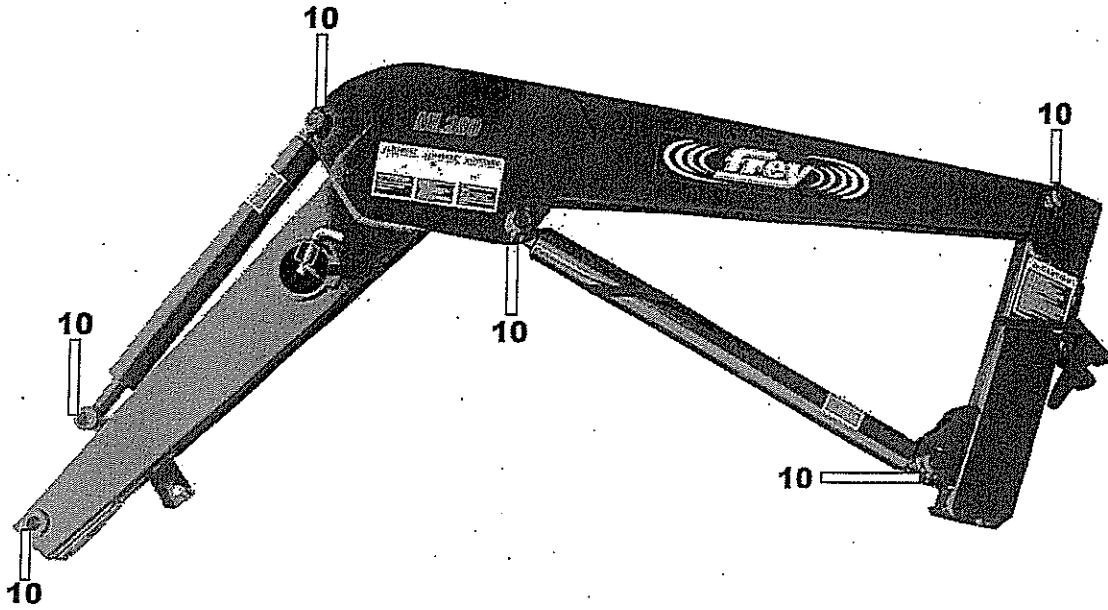

**Every 10 Hours**

- Lubricate fittings on each side of loader

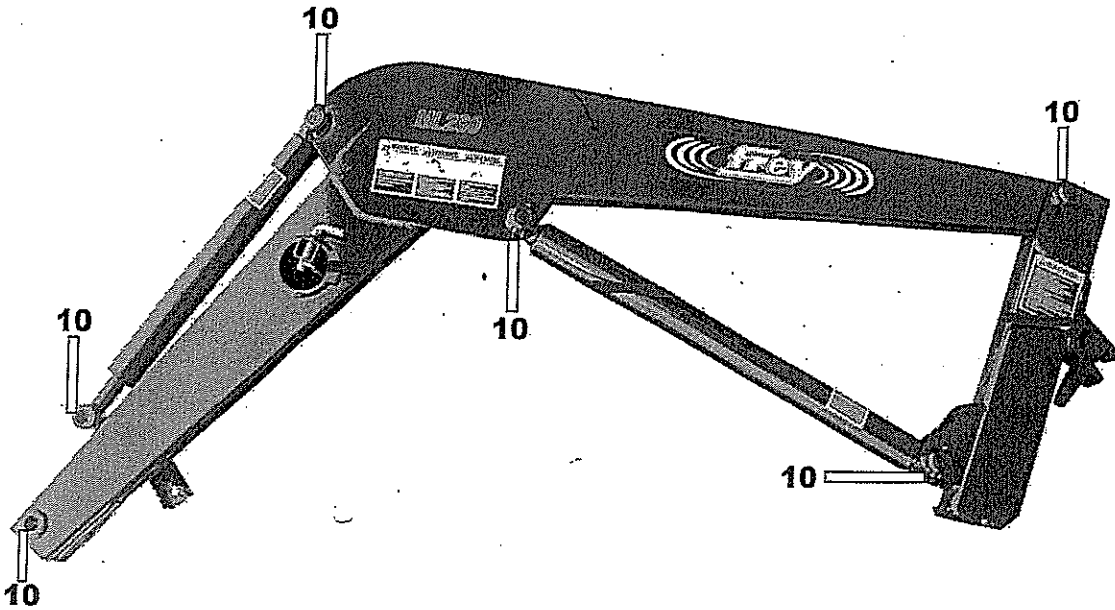

**Every 50 Hours**

- Tighten Loader Frame Mounting Hardware

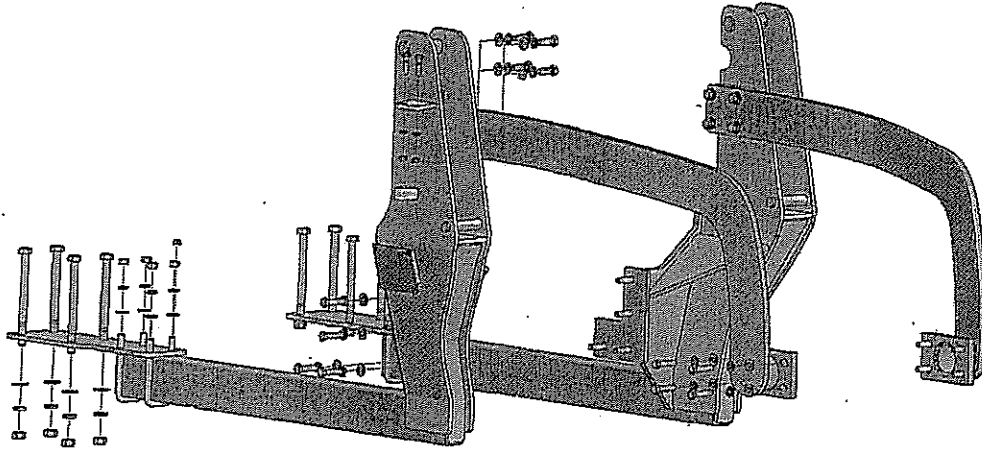

**IMPORTANT:** Help Prevent damage to the tractor or loader  
Caused by operating with loose mounting hardware. Tighten loader mounting frame hardware after the first 10 hours of operation and again after every 50 hours.

# NOTICE

## INSTALLATION OF HYDRAULIC VALVE

When installing the hydraulic control valve on the front end loader, it is very important that the operator does not reverse the flow of the oil through the valve. The control valve has backpressure ratings of (1100 p.s.i.), however, if the flow of oil is accidentally reversed, the valve will receive full tractor pressure which will exceed 2000 p.s.i. If the valve receives more than the rated 1100 p.s.i. backpressure, the seals and gaskets will be damaged and excessive leakage will occur.

When installing the control valve, it is recommended connecting the return line directly back to sump on the tractor which will ensure the oil cannot change direction through the valve. If this is not possible the operator must be aware that he cannot change oil flow through the valve.

## HYDRAULIC VALVE INSTALLATION

To prevent back pressure in hydraulic control valve the following steps should be taken:

### 1. OPEN CENTRE VALVE

When installing this valve the pressure line should be connected to the remote valves on the tractor. The return port on the valve should be installed directly into the tractor transmission or sump. When installing in this manner, the risk of creating excessive back pressure is eliminated.

### 2. POWER BEYOND VALVE

The power beyond valve is recommended on all tractors. When using this valve the hydraulic lines from the loader valve will be connected directly into hydraulic lines on the tractor. The pressure line on the loader valve should be connected to the pressure line on the tractor hydraulic pump. The power beyond port on the valve, the line should be connected to the return side of the pressure line on the pump of the tractor. The return line on the valve should be connected to the reservoir on the tractor. (Refer to the hydraulic schematic).

**NOTE:** Warranty is void on all valves that are damaged due to backpressure.