

Tube-Line 5500

Parts & Service

1999

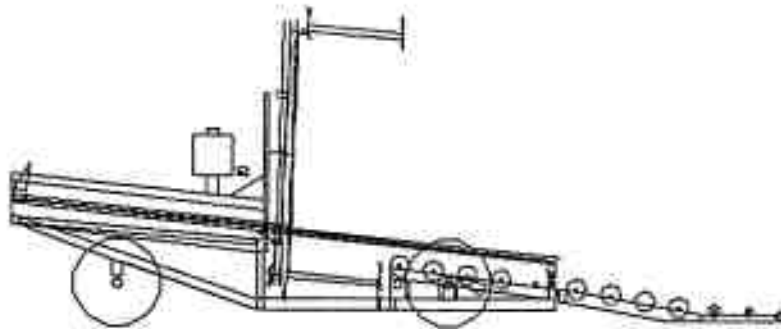

Notes

Electric Solenoid valves can be manually operated by pushing a small punch into the end of spool and holding it in.

Caution Stay Away From Hoop When Engine Is Running

Inside of Control Panel , control relays are numbered CR1 to CR5 from left to right.

Relay CR1 is wired to table trigger. CR1 will activate solenoid valve to extend ram cylinder. CR2 is wired to switch at the front slider, when ram is extended to this switch CR2 will close, energizing the wrap motor valve. Ram cylinder will extend and wrap motor will turn until ram comes in contact with slider switch at rear, then CR1 and CR2 will turn off and CR3 will turn on. Wrap motor will stop and ram cylinder will retract until ram cylinder trips limit switch at front end of table. All controls will then turn off. Testing can be done by pushing trigger plate and wait until machine goes through cycle, or you can push small square button on the front of relay 1 and let machine go through cycle.

When control relays are activated a small light goes on inside the relay.

When running machine through the cycle and wrapper motor or the cylinders do not work, check flowcontrol valve to see if flow is going to both motor and cylinder.

Engine is stopped by grounding ignition, in case of ignition failure make sure that stop switch wire to frame and engine switch is not in stop position.

Steering is controlled by switch right/left on control panel through CR5 and CR6 activating coil A or B on steering solenoid valve.

TUBE-LINE 5500

Parts Manual

Index

Hoop	1
Hoop Wheels and Axle	2
Wrapper Hardware	3
Hoop Brace	4
Safety Mesh	5
Drive Wheel & Hydraulic Motor	6
Hubs	7
Brakes	8
Rear Roller	9
Tail	10
Bale Saddle	11
Ram	12
Push Tube	13
Pushoff Channel	14
Tongue	15
Mud Flap	16
Hydraulic Tank and Filter	17
Engine and Hydraulic Pump	18
Engine Cover and Decal Plate	19
Hydraulic Valve (manual)	20
Hydraulic Valve (electric)	21
Limit Switch	22
Control Panel	23
Bale Trigger and Battery Holder	24
Throttle	25
Hydraulic Schematic Diagram (manu	26
Hydraulic Schematic Diagram (electr	27
Electric Wiring Diagram	28
Electric Schematic Diagram (electric	29
Sequence Of Operation (manual)	30
Sequence Of Operation (electric)	31
Part Number	
Hydraulic Valve Parts	

Tube-Line 550
Hoop

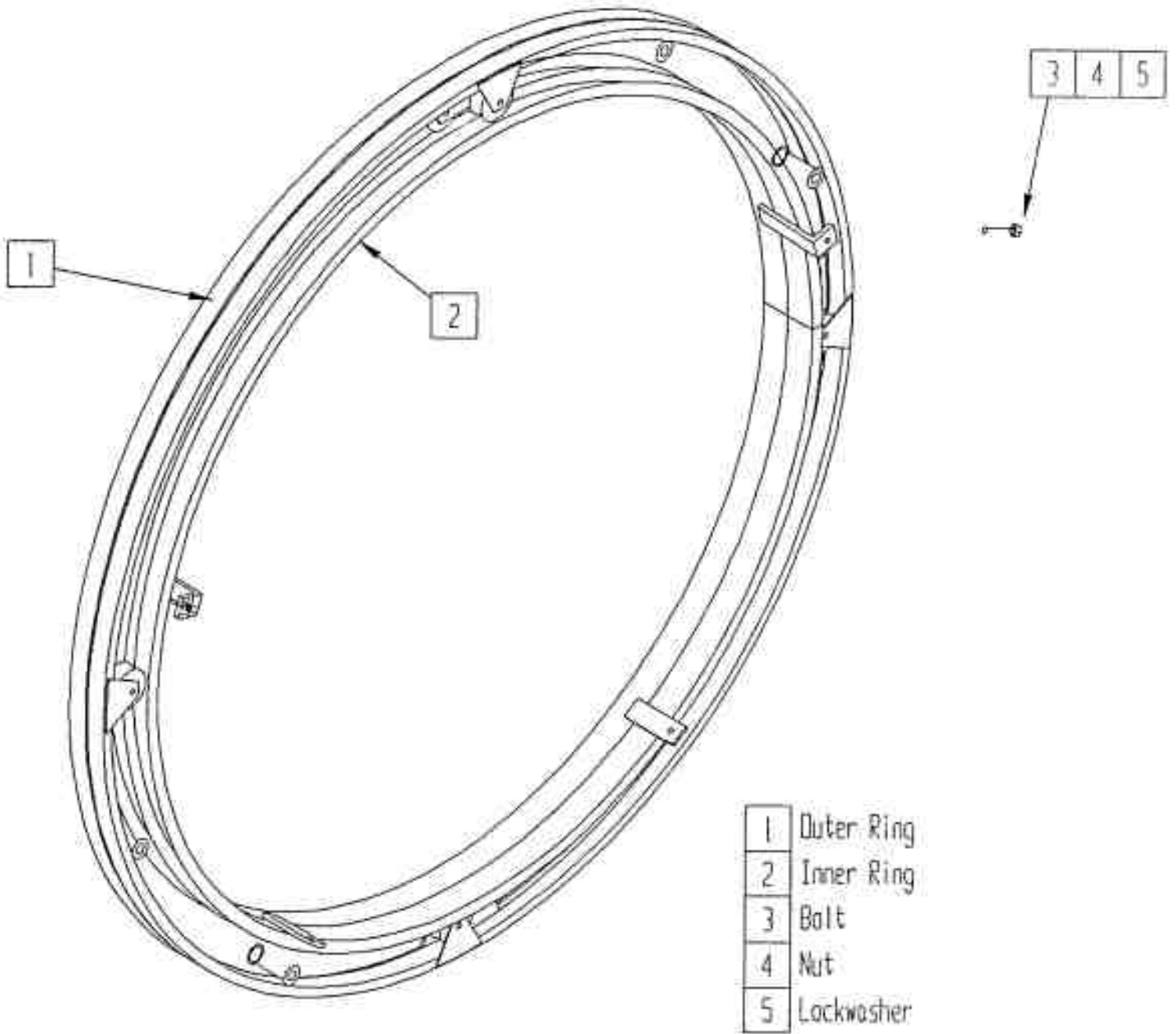

Tube-Line 550

Hoop wheels

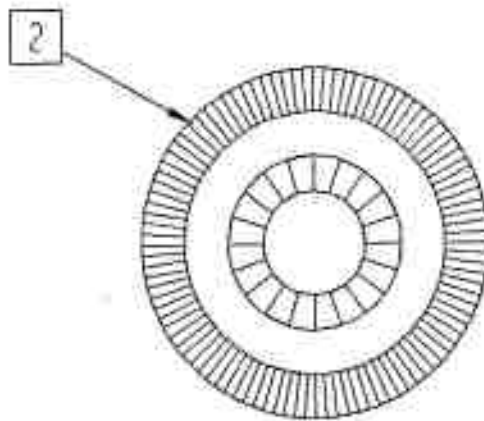
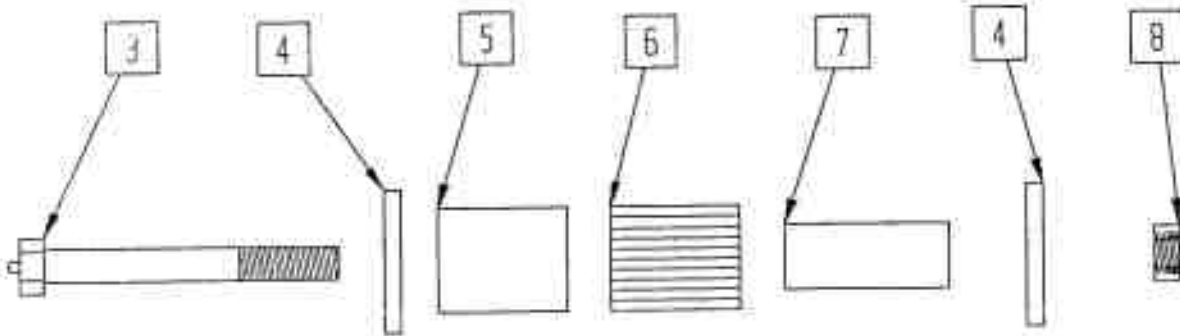

- | | |
|---|----------------|
| 2 | 4 in wheel |
| 3 | axle bolt |
| 4 | bearing seal |
| 5 | outer race |
| 6 | roller bearing |
| 7 | inner race |
| 8 | locknut |

Tube - Line 550
Plastic Wrap Carrier

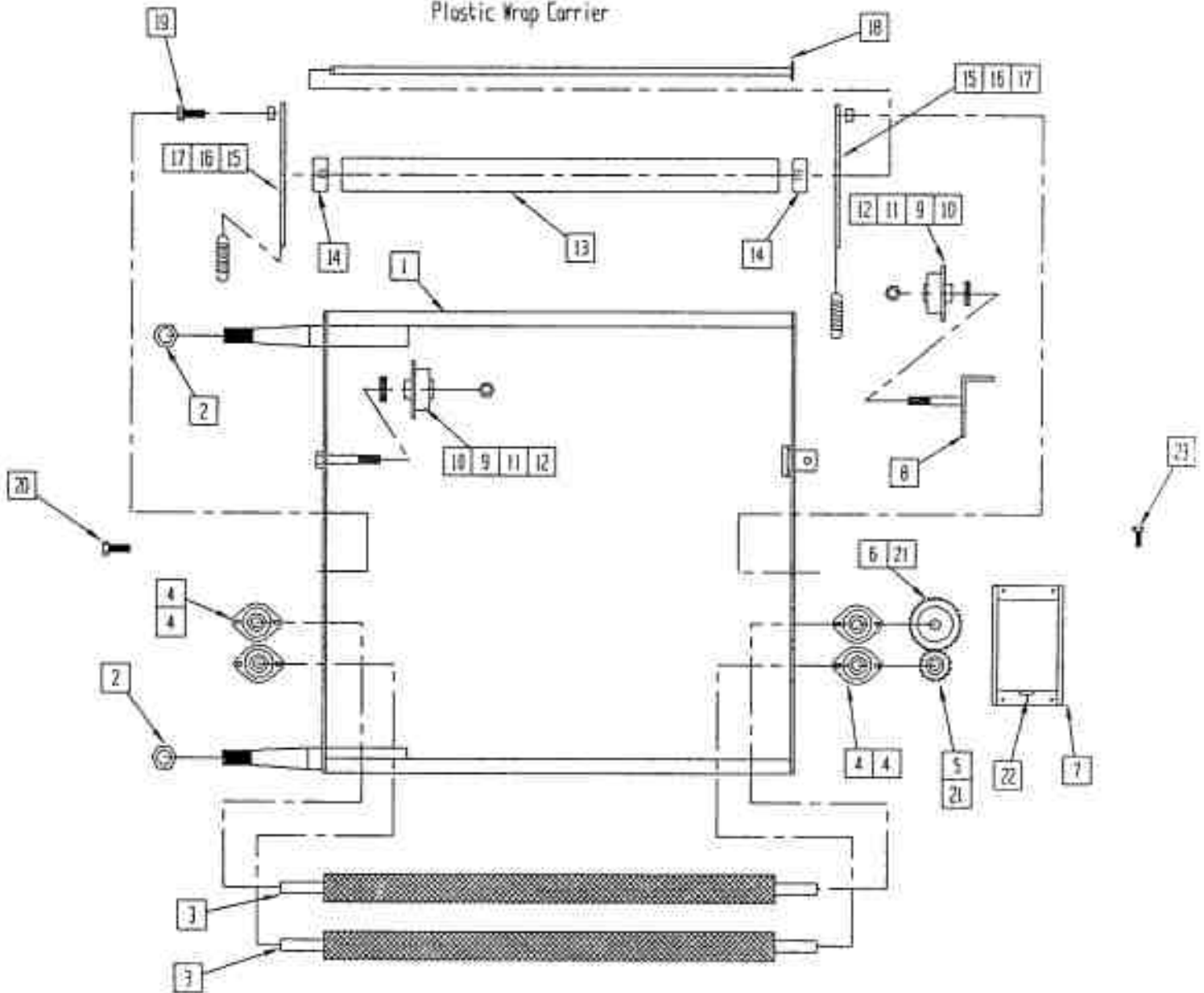

- | | | | |
|----|--------------------|----|--------------------------|
| 1 | Main Wrap Bracket | 13 | ABS Pipe |
| 2 | 1-14 UNC Nut | 14 | HMPVC Bearing |
| 3 | Tensioner Roller | 15 | ABS Bracket |
| 4 | 3/4 Bearing | 16 | Spacer |
| 5 | Small Gear | 17 | Spring |
| 6 | Large Gear | 18 | ABS Axle |
| 7 | Gear Cover | 19 | 1/2 x 2 Bolt |
| 8 | Spool Holder | 20 | 5/16 Carriage Bolt |
| 9 | Plastic Wrap Spool | 21 | 3/16 Keystock |
| 10 | 5/8 Flat washer | 22 | Grease Fitting |
| 11 | 5/8 Nylocknut | 23 | 10-24 x 3/4 Machine Bolt |
| 12 | Ball Bearing | | |

TubeLine S99
Hoop Brace

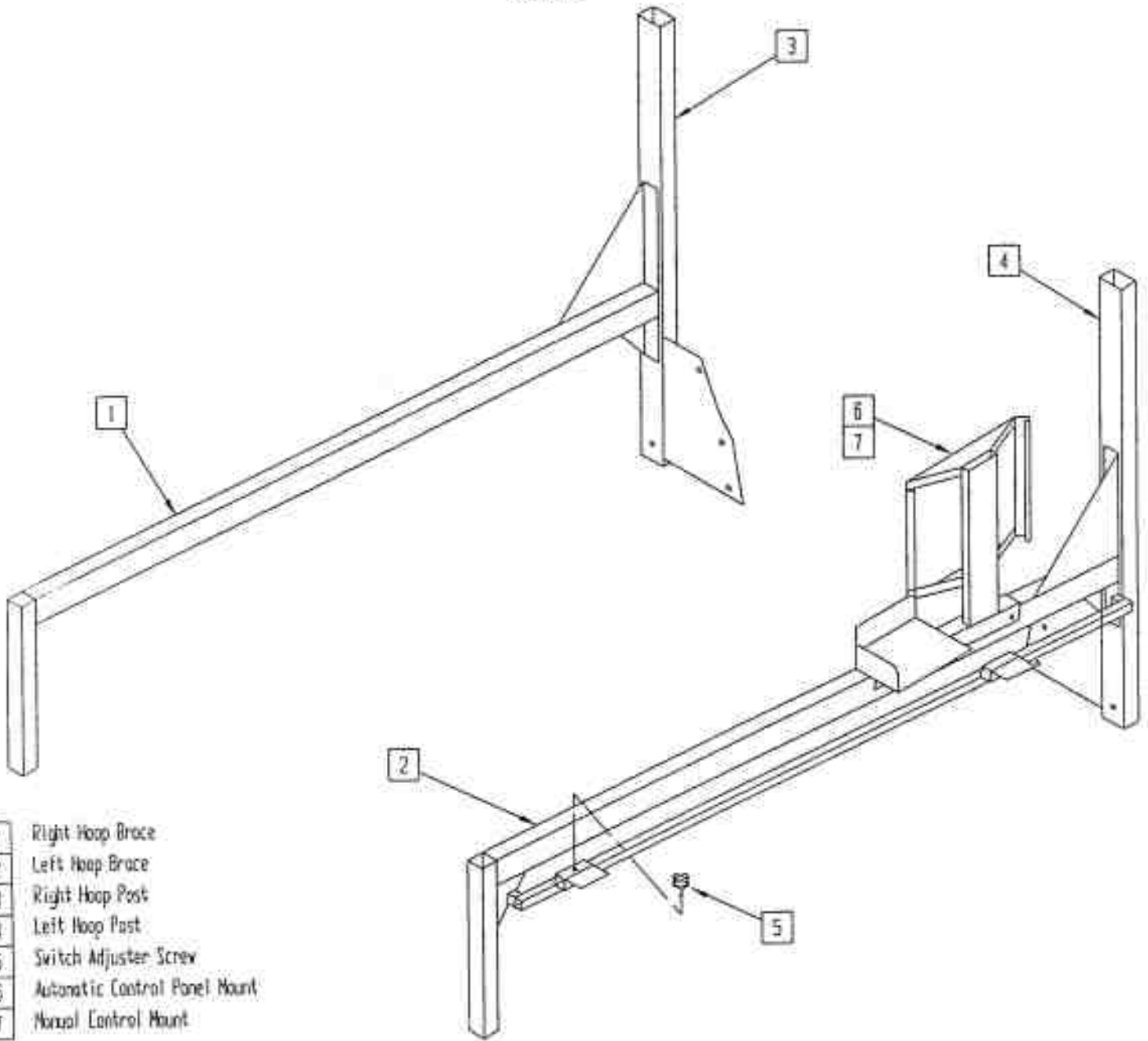

- | | |
|---|-------------------------------|
| 1 | Right Hoop Brace |
| 2 | Left Hoop Brace |
| 3 | Right Hoop Post |
| 4 | Left Hoop Post |
| 5 | Switch Adjuster Screw |
| 6 | Automatic Control Panel Mount |
| 7 | Manual Control Mount |

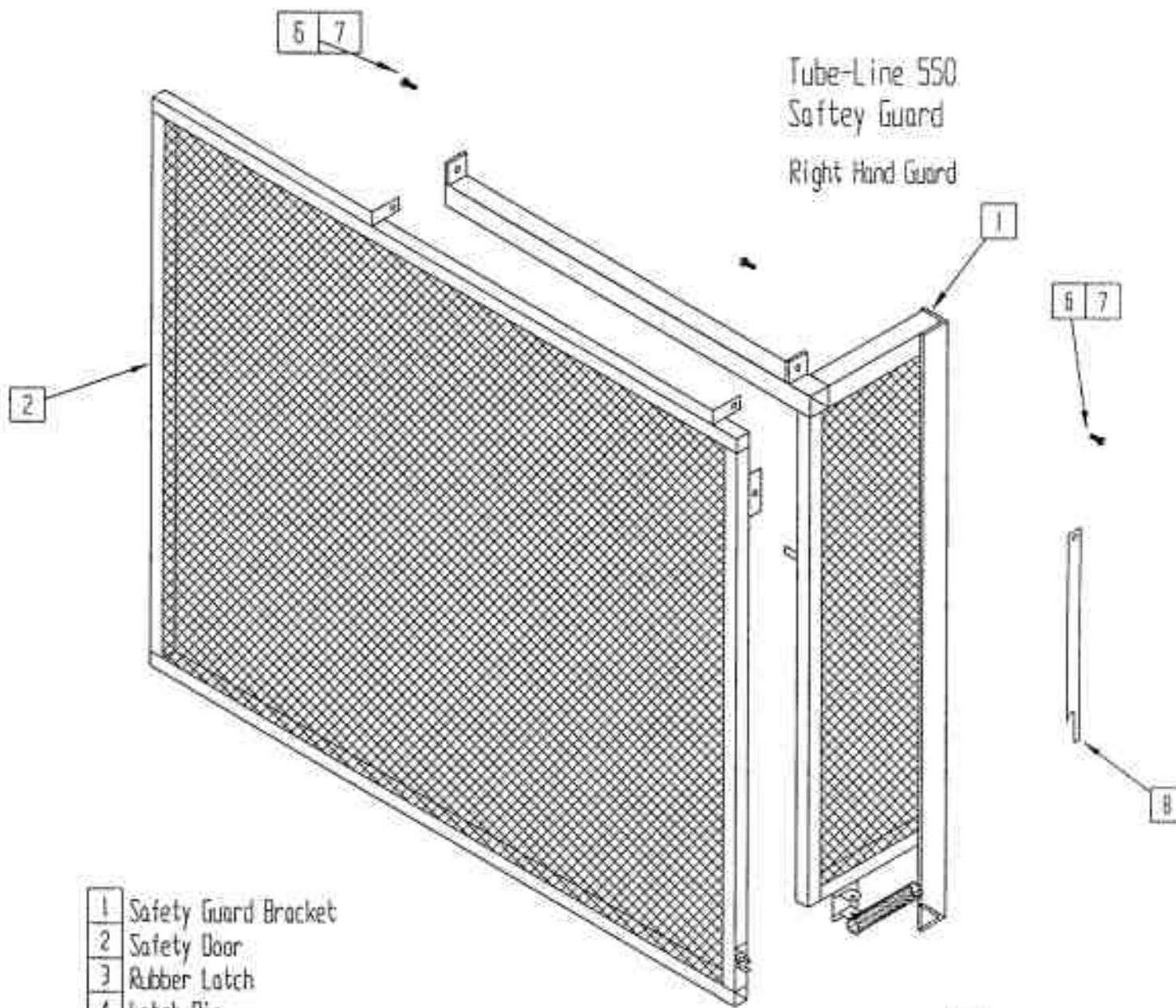

Tube-Line 550
 Safety Guard
 Right Hand Guard

- | | |
|---|------------------------|
| 1 | Safety Guard Bracket |
| 2 | Safety Door |
| 3 | Rubber Latch |
| 4 | Latch Pin |
| 5 | Cotter Pin |
| 6 | 3/8 x 1 1/4 Hinge Bolt |
| 7 | 3/8 Locknut |
| 8 | Door Stay |

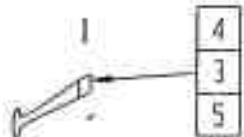

Tube-Line 550

Drive wheel

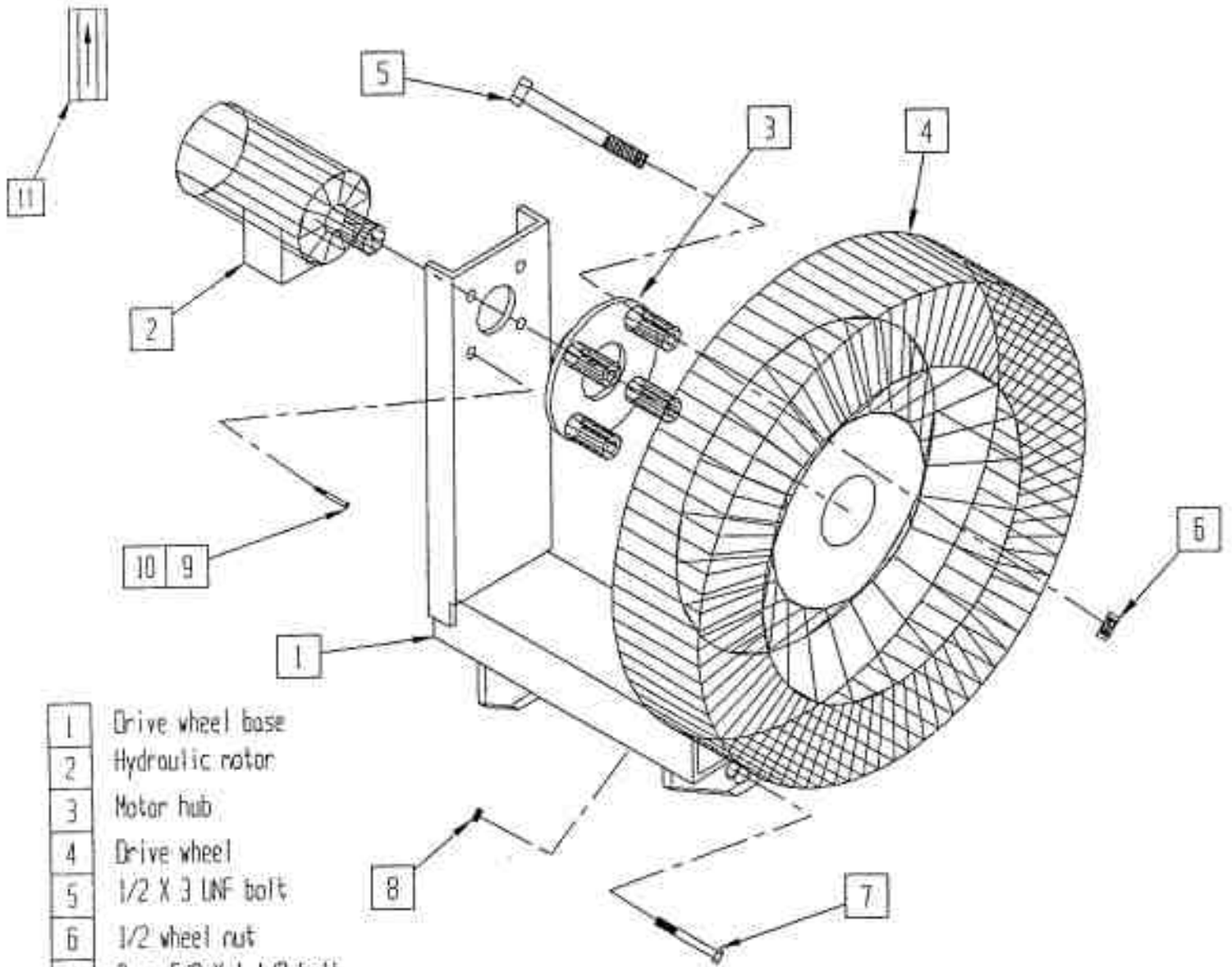

- | | |
|----|-----------------------|
| 1 | Drive wheel base |
| 2 | Hydraulic motor |
| 3 | Motor hub |
| 4 | Drive wheel |
| 5 | 1/2 X 3 LNF bolt |
| 6 | 1/2 wheel nut |
| 7 | 2 pc 5/8 X 1 1/2 bolt |
| 8 | 2 pc 5/8 locknut |
| 9 | 4 pc 3/8 X 3/4 bolt |
| 10 | 4 pc 3/8 lockwasher |
| 11 | Check Valve |

Tube-Line 550

Axle/spindle/hub

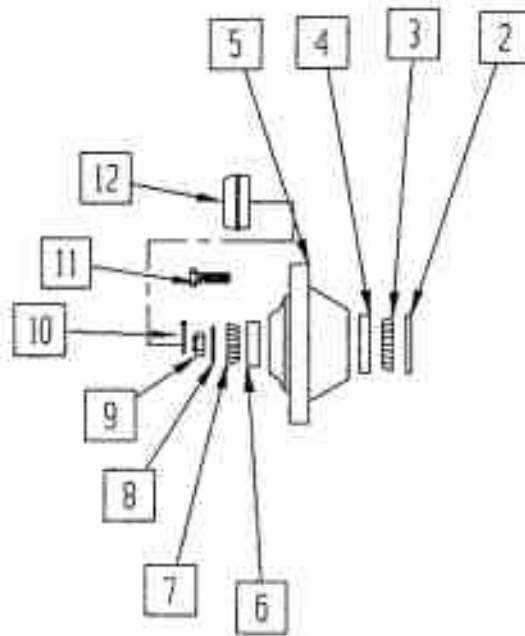

2	seal
3	inner bearing
4	inner bearing race
5	hub
6	outer bearing race
7	outer bearing
8	flat washer
9	wheel nut
10	cotter pin
11	wheel stud
12	dust cap

Tube - Line 550
Brakes

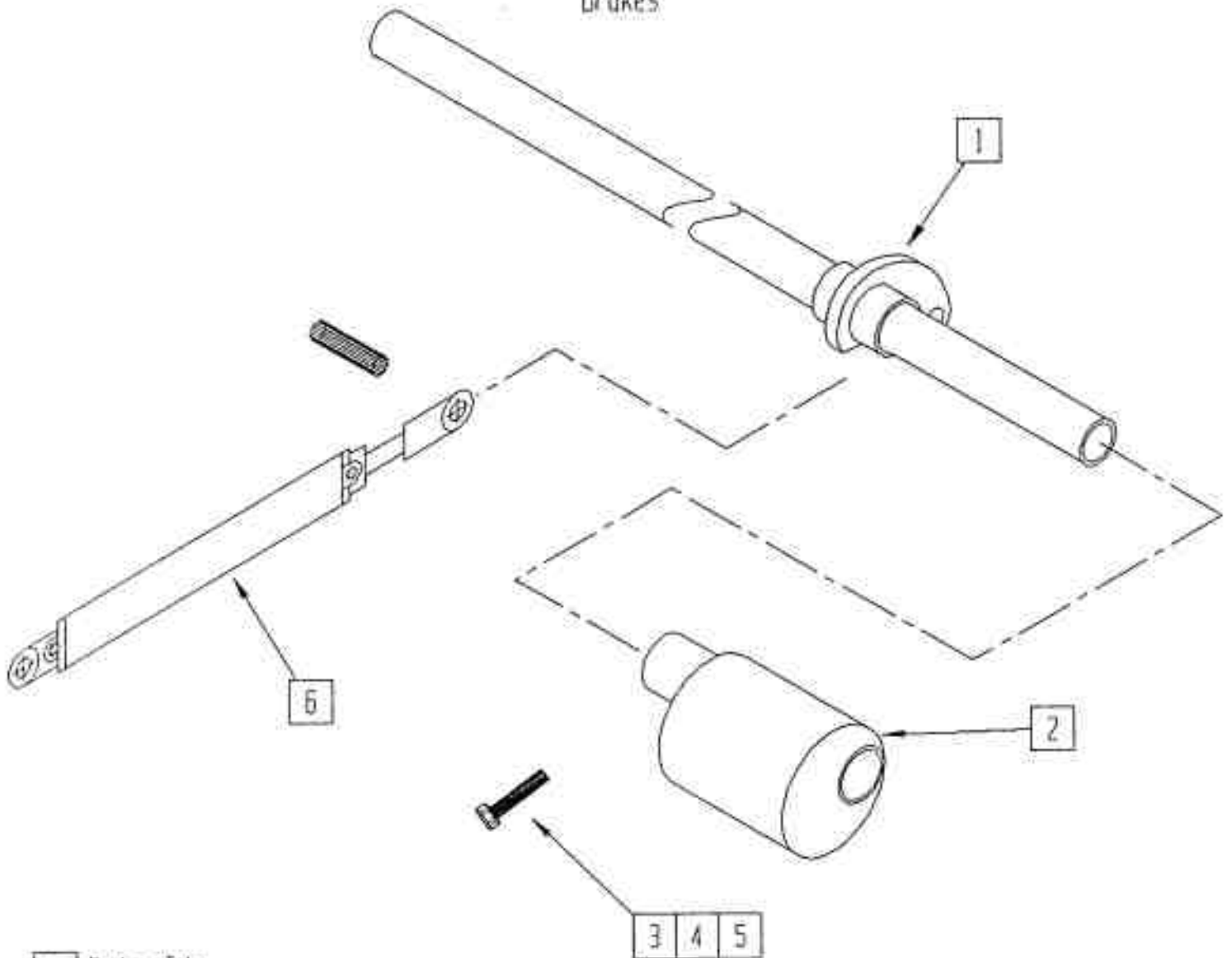

- | | |
|---|---------------------------|
| 1 | Rocker Tube |
| 2 | 2 pc broke eccentric |
| 3 | 2 pc 1/2 x 3 1/2 bolt |
| 4 | 2 pc lockwasher |
| 5 | 2 pc 1/2 nut |
| 6 | 2 x 16 hydraulic cylinder |

Tube-Line 599

rear roller

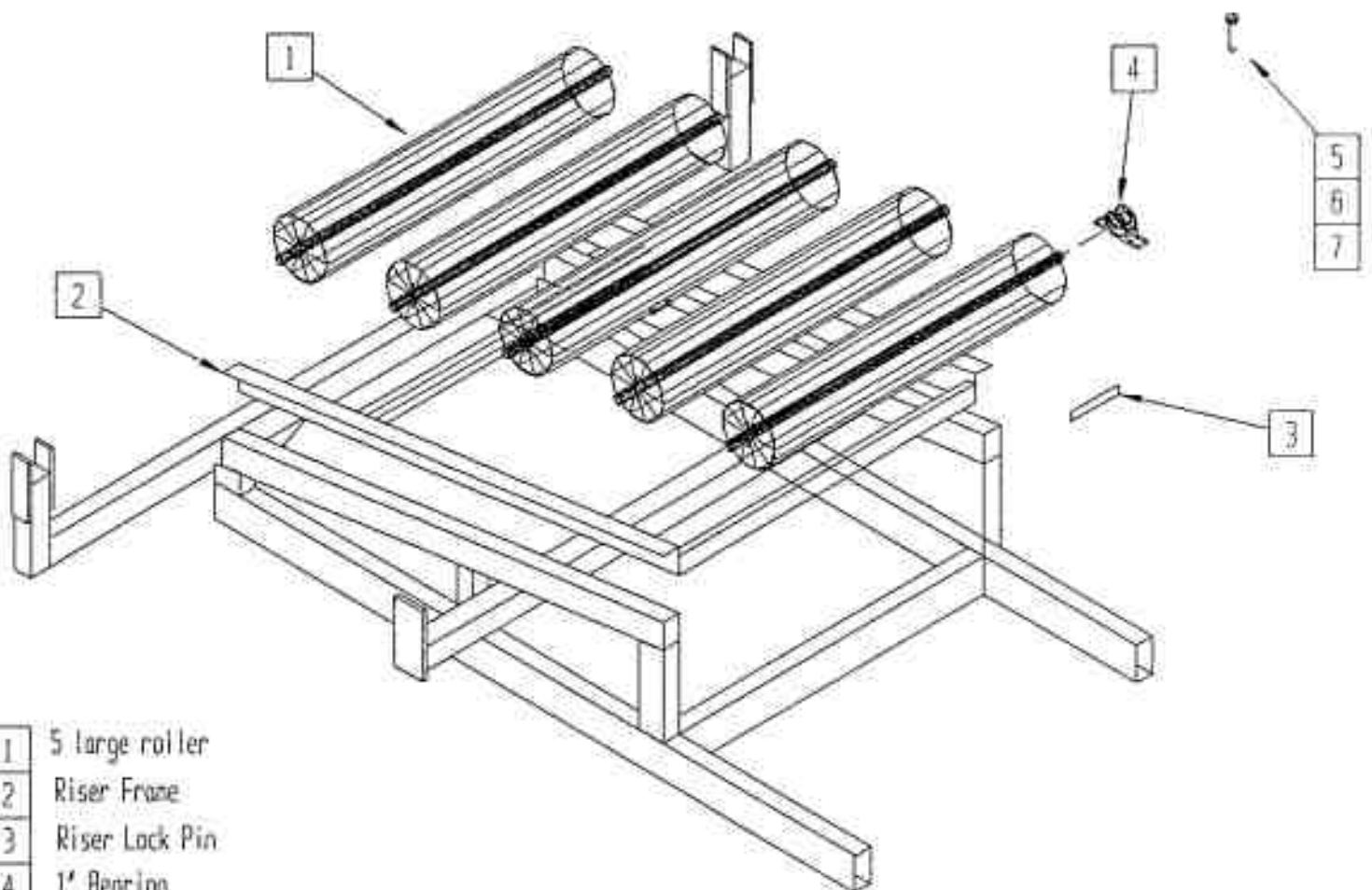

- | | |
|---|------------------------|
| 1 | 5 large roller |
| 2 | Riser Frame |
| 3 | Riser Lock Pin |
| 4 | 1' Bearing |
| 5 | 20 pc 3/8 x 1 1/2 Bolt |
| 6 | 20 pc 3/8 lockwasher |
| 7 | 20 pc 3/8 Flatwasher |

Tube-Line 599
Tail

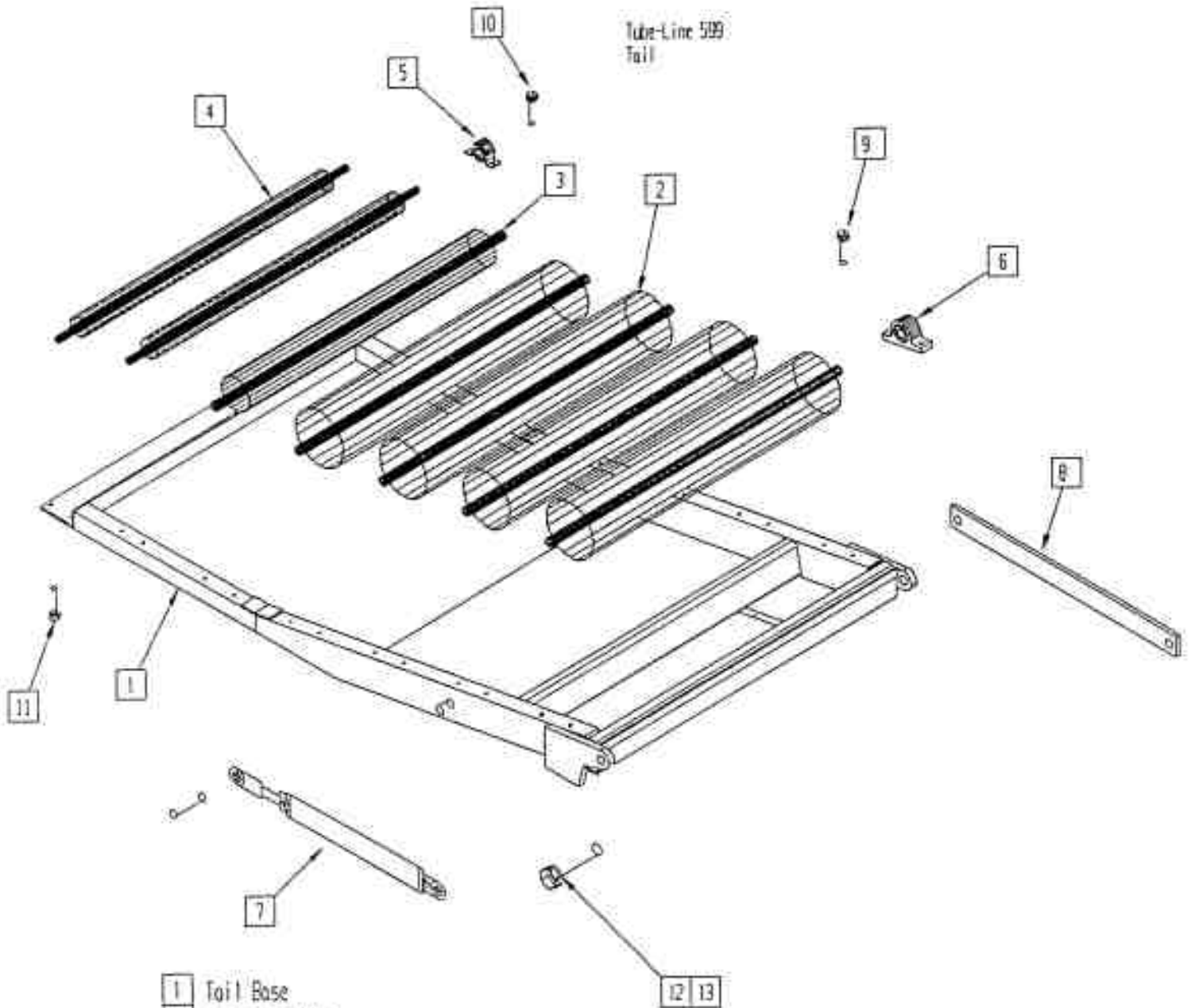

- | | |
|----|------------------------------------|
| 1 | Tail Base |
| 2 | 4 large roller |
| 3 | 1 pc 4' roller |
| 4 | 2 pc 2 3/8" roller |
| 5 | 4 pc 3/4" bearing |
| 6 | 10 pc 1" bearing |
| 7 | 2 X 16 hydraulic cylinder |
| 8 | tail tie bar |
| 9 | 3/8 x 1 3/4 bolt |
| 10 | 5/16 x 1 bolt |
| 11 | 4 pc 5/16 x 1 1/2 countersink bolt |
| 12 | 2 pc 1 x 3 1/2 bolt |
| 13 | 2 pc 1" Nylocknut |

Tubeline 550
Bale Saddle

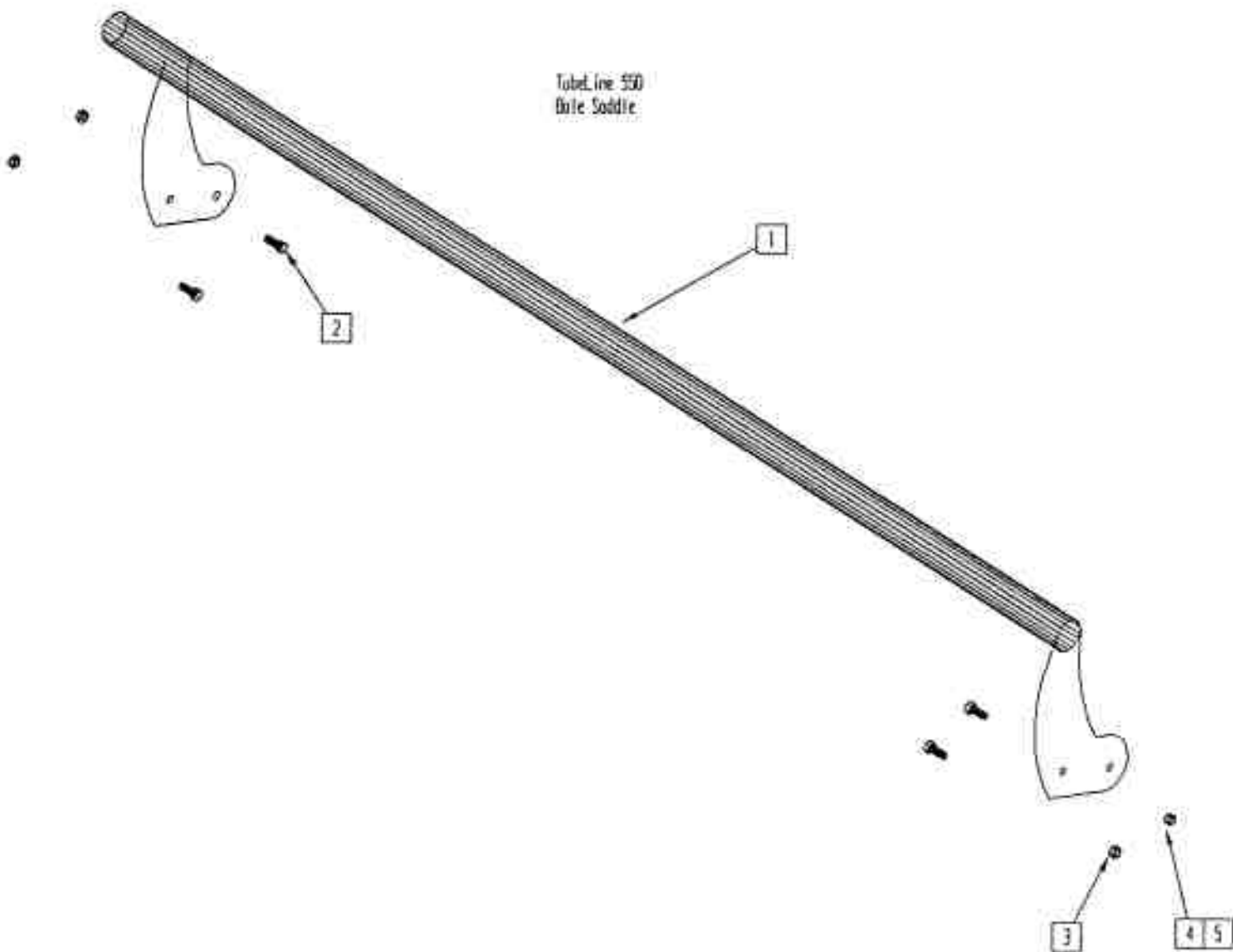

- | | |
|---|------------------|
| 1 | Saddle |
| 2 | 1/2 x 1 1/4 bolt |
| 3 | 1/2 locknut |
| 4 | 1/2 nut |
| 5 | 1/2 lockwasher |

Tube-Line 550

Ran

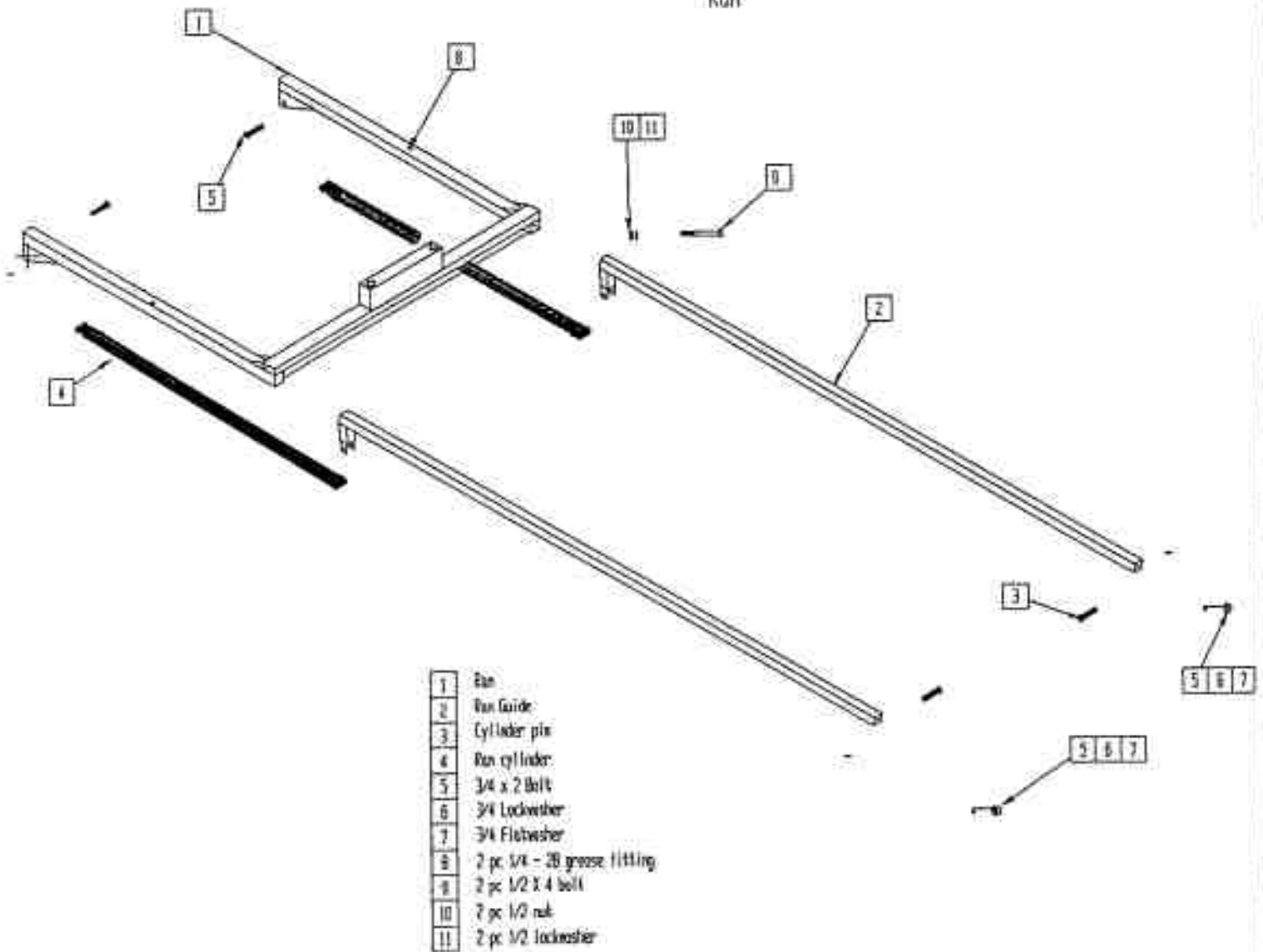

Tube-Line 5500
Push-Off

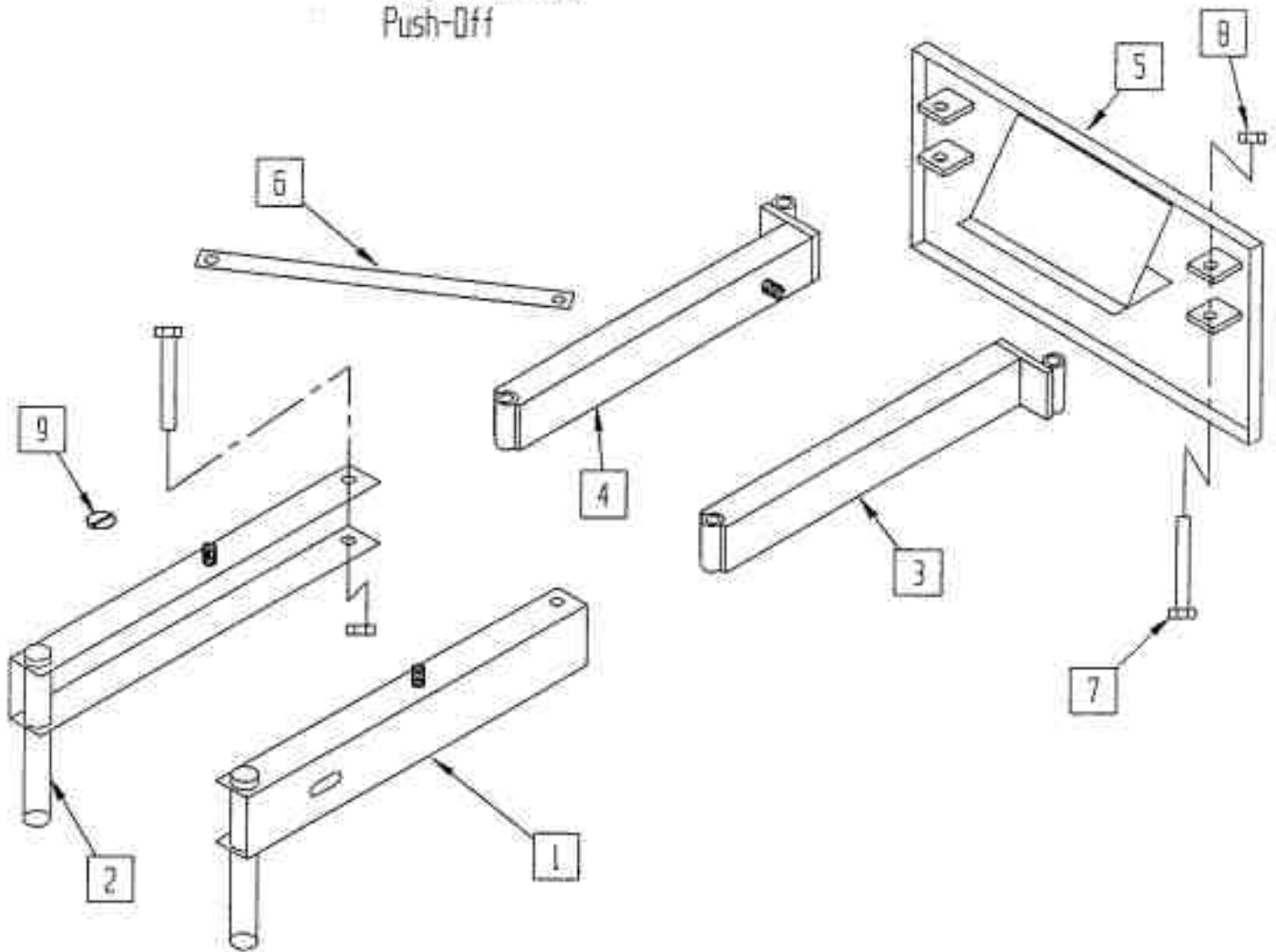

1	Left Front Arm
2	Right Front Arm
3	Left Rear Arm
4	Right Rear Arm
5	Push Plate
6	2 pc X Bar
7	4 pc 3/4 x 5 Bolt
8	4 pc 3/4 Nylocknut
9	4 pc 3/16 Linch Pin

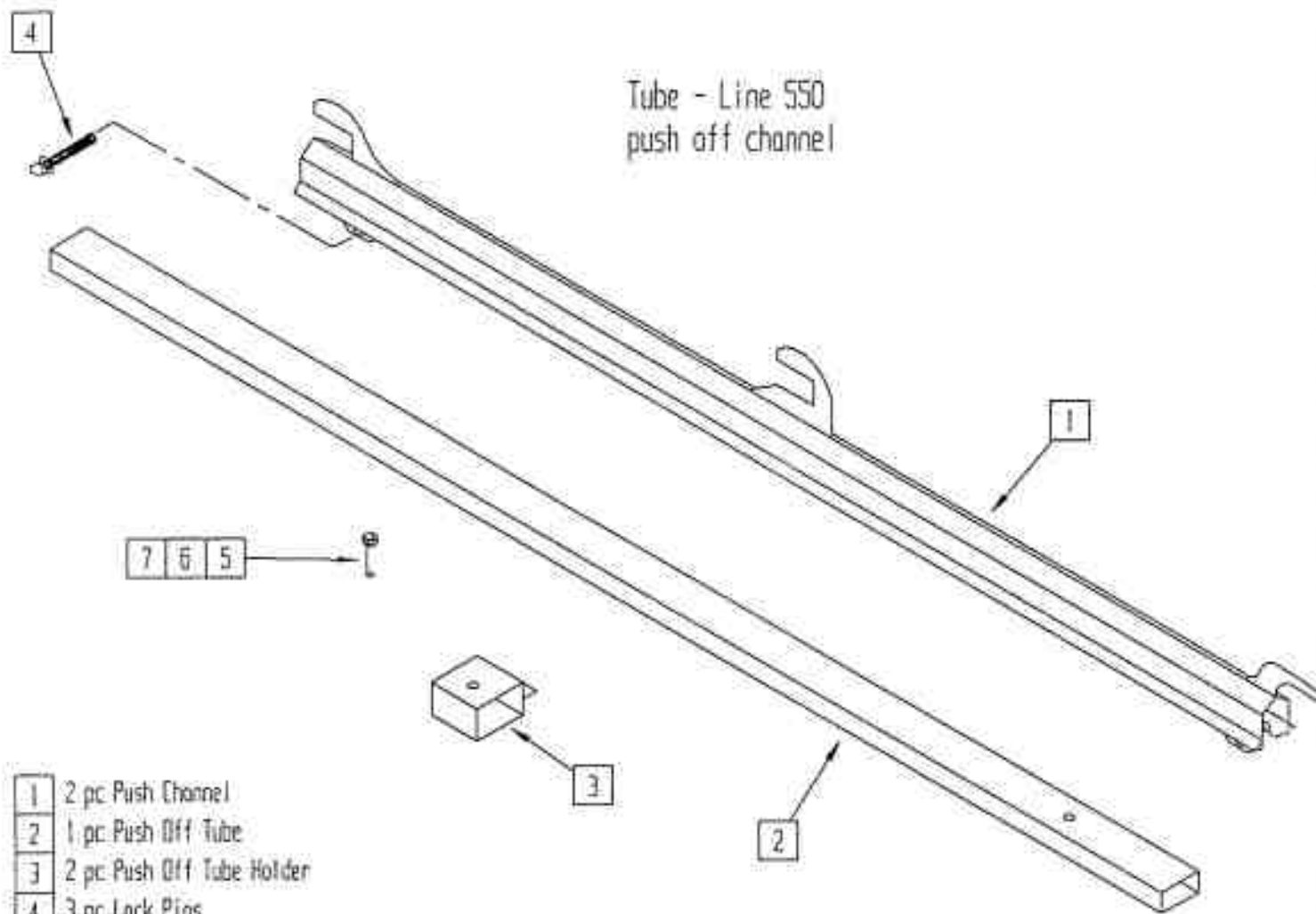

Tube - Line 550
push off channel

- | | |
|---|---------------------------|
| 1 | 2 pc Push Channel |
| 2 | 1 pc Push Off Tube |
| 3 | 2 pc Push Off Tube Holder |
| 4 | 3 pc Lock Pins |
| 5 | 4 pc 3/8 x 1 bolt |
| 6 | 4 pc 3/8 nut |
| 7 | 4 pc 3/8 lockwasher |

Tube-Line 500

Mud Flap

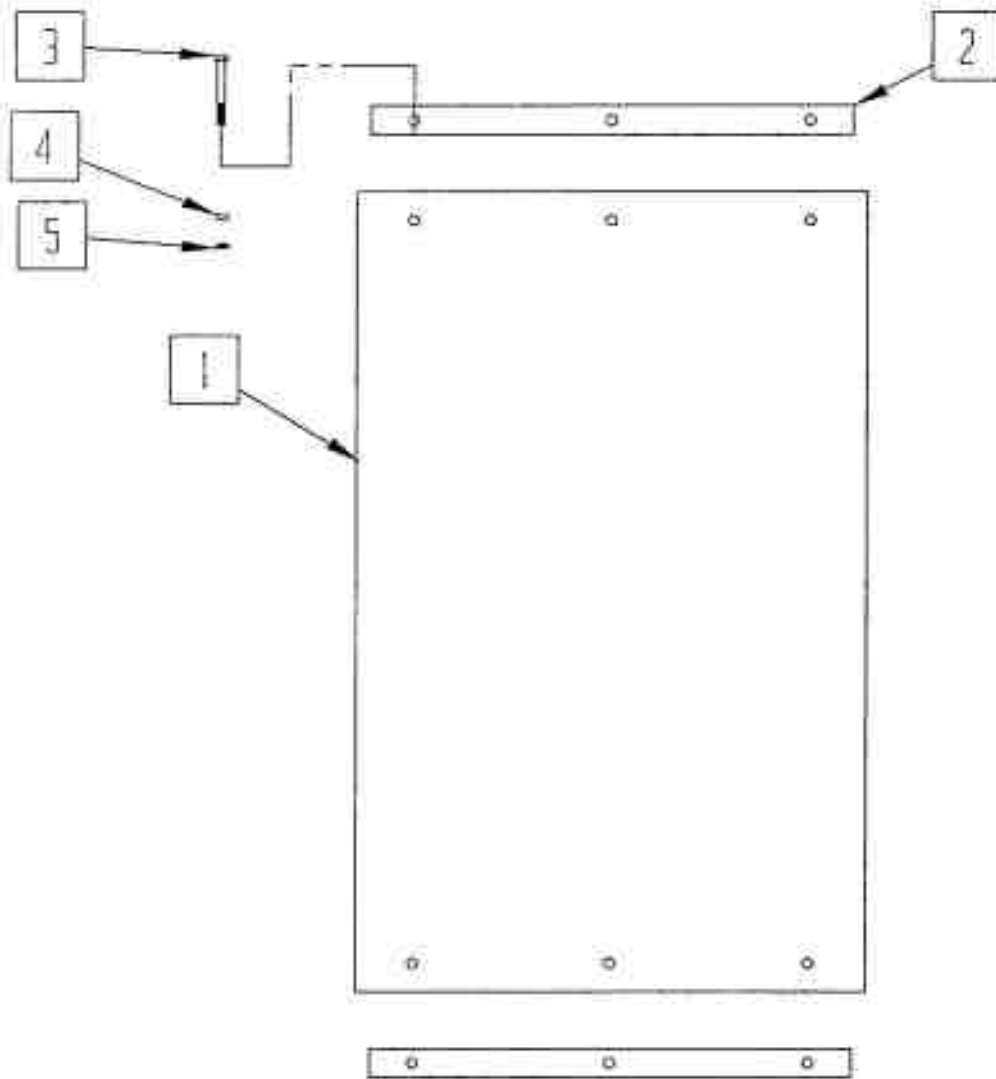

- | | |
|---|-------------|
| 1 | mud flap |
| 2 | metal strip |
| 3 | bolt |
| 4 | lockwasher |
| 5 | nut |

Tube-Line 550

Hydraulic tank

Filter cross/ref
 Stauff SF6520
 Gresen F22001
 Fran P1653-A
 Fleetguard HF6510
 Cross 1A9021

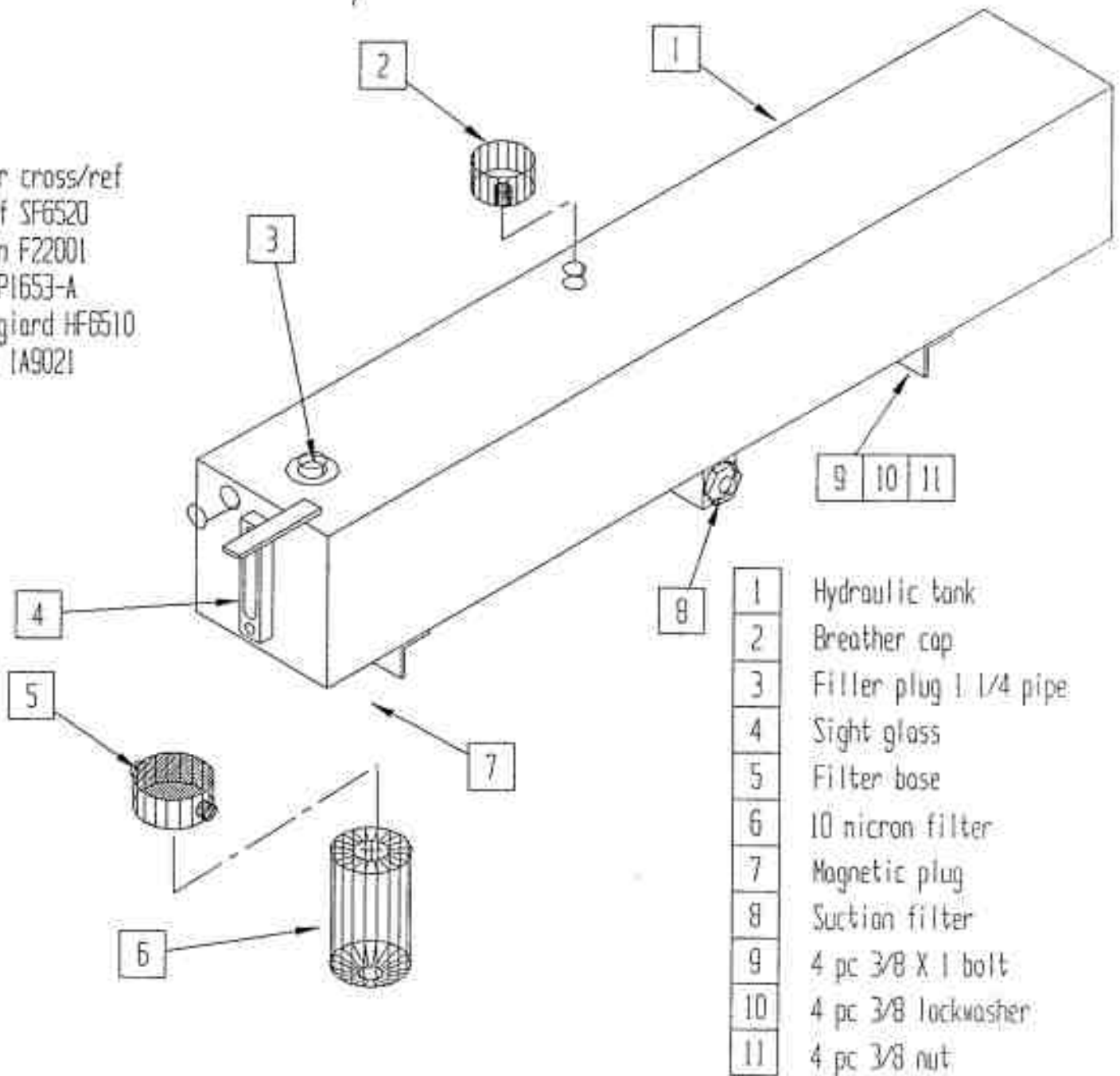

Tube-Line 550

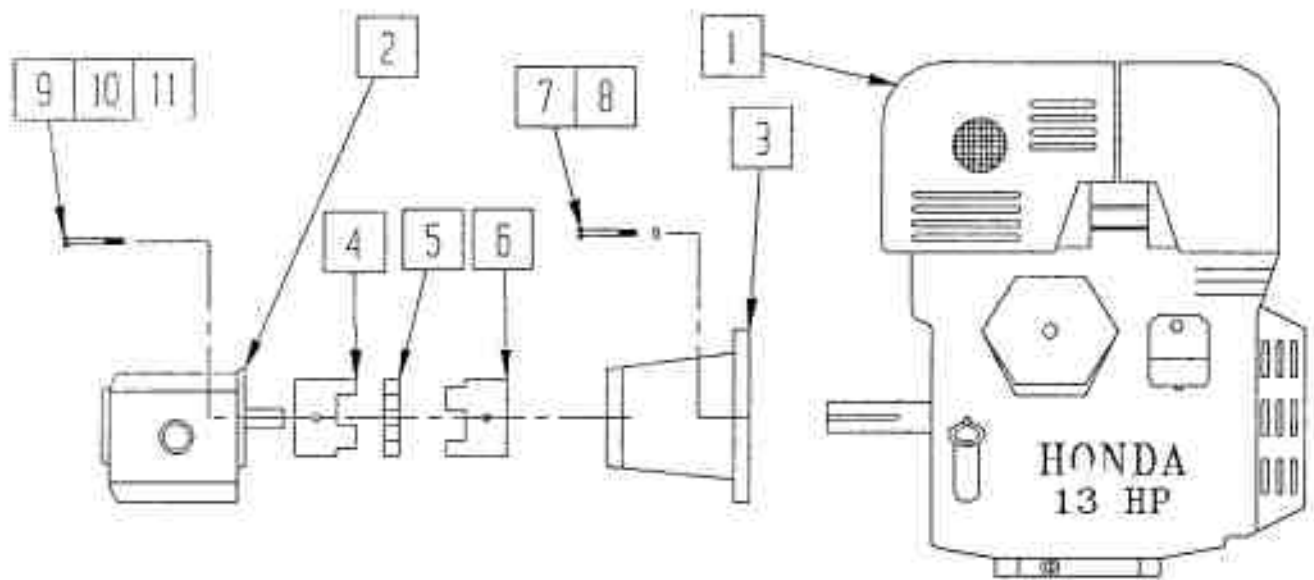

- | | |
|---|--------------------------|
| 1 | 13 Hp HONDA Engine |
| 2 | Hydraulic Pump |
| 3 | Engine to pump adaptor |
| 4 | Love Joy Coupling |
| 5 | Coupling spacer |
| 6 | Love Joy Coupling engine |

- | | |
|----|---------------------|
| 7 | 4 pc 3/8 X 1 bolt |
| 8 | 4 pc 3/8 lockwasher |
| 9 | 2 pc 3/8 1 1/4 bolt |
| 10 | 2 pc 3/8 lockwasher |
| 11 | 2 pc 3/8 flatwasher |

Tube-Line 550

Engine cover & decal plate

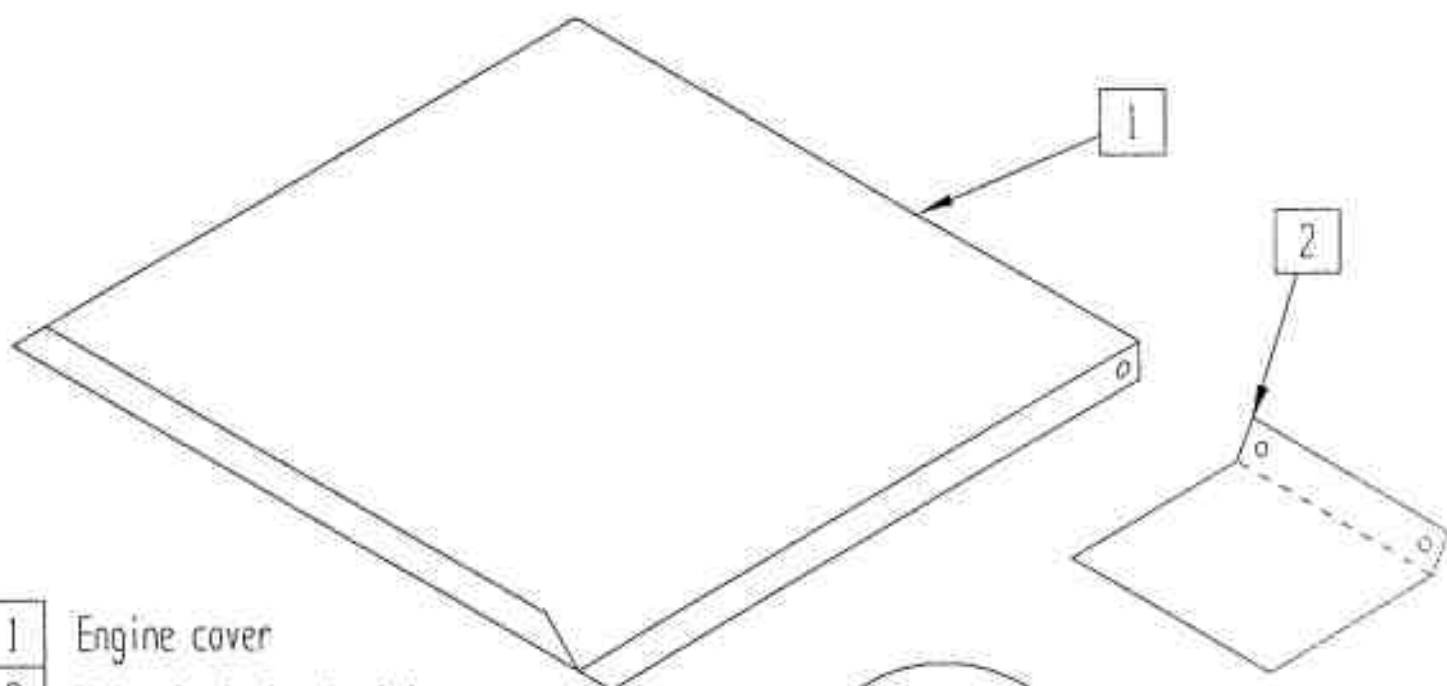

- | | |
|---|------------------------------------|
| 1 | Engine cover |
| 2 | Valve bank decal plate |
| 3 | Selector valve decal plate |
| 4 | Selector valve decal plate bracket |

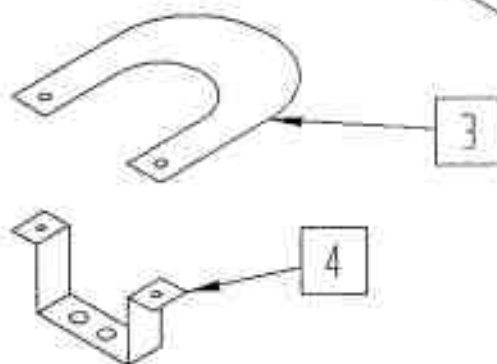

Tube-Line 500
Normal valve bank

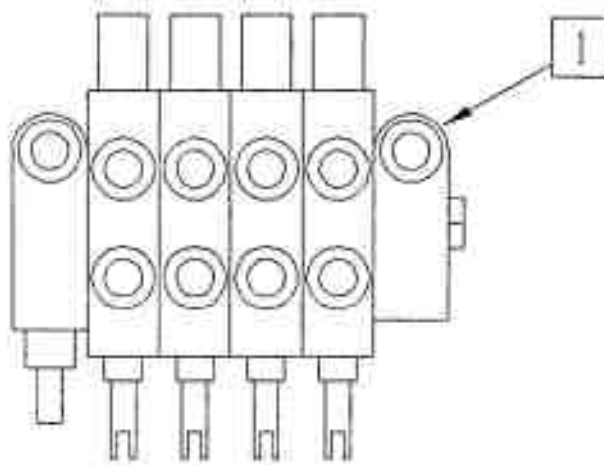
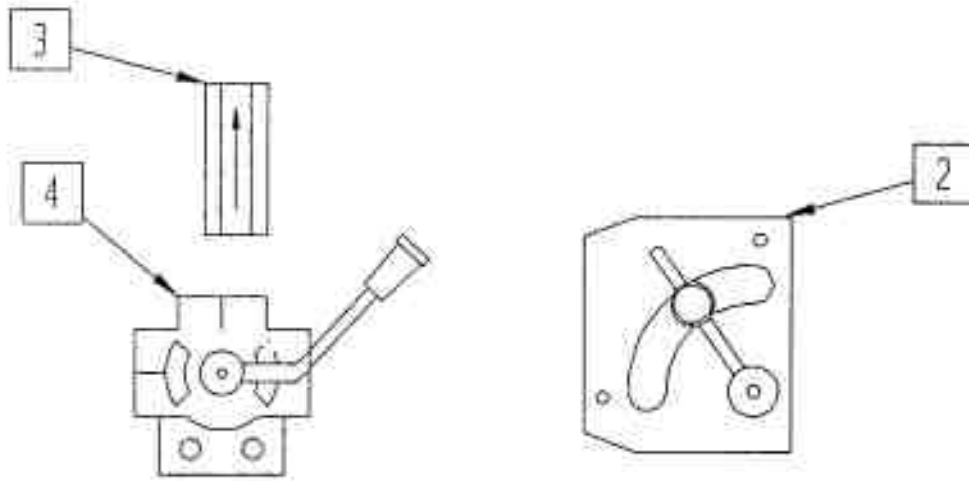

- | | |
|---|----------------------------|
| 1 | CPV0014 Valve stack |
| 2 | RD - 150 - 08 Flow control |
| 3 | 1/2 Check valve |
| 4 | Selector Valve |

Tube-Line 550
Electric Solenoid Valve

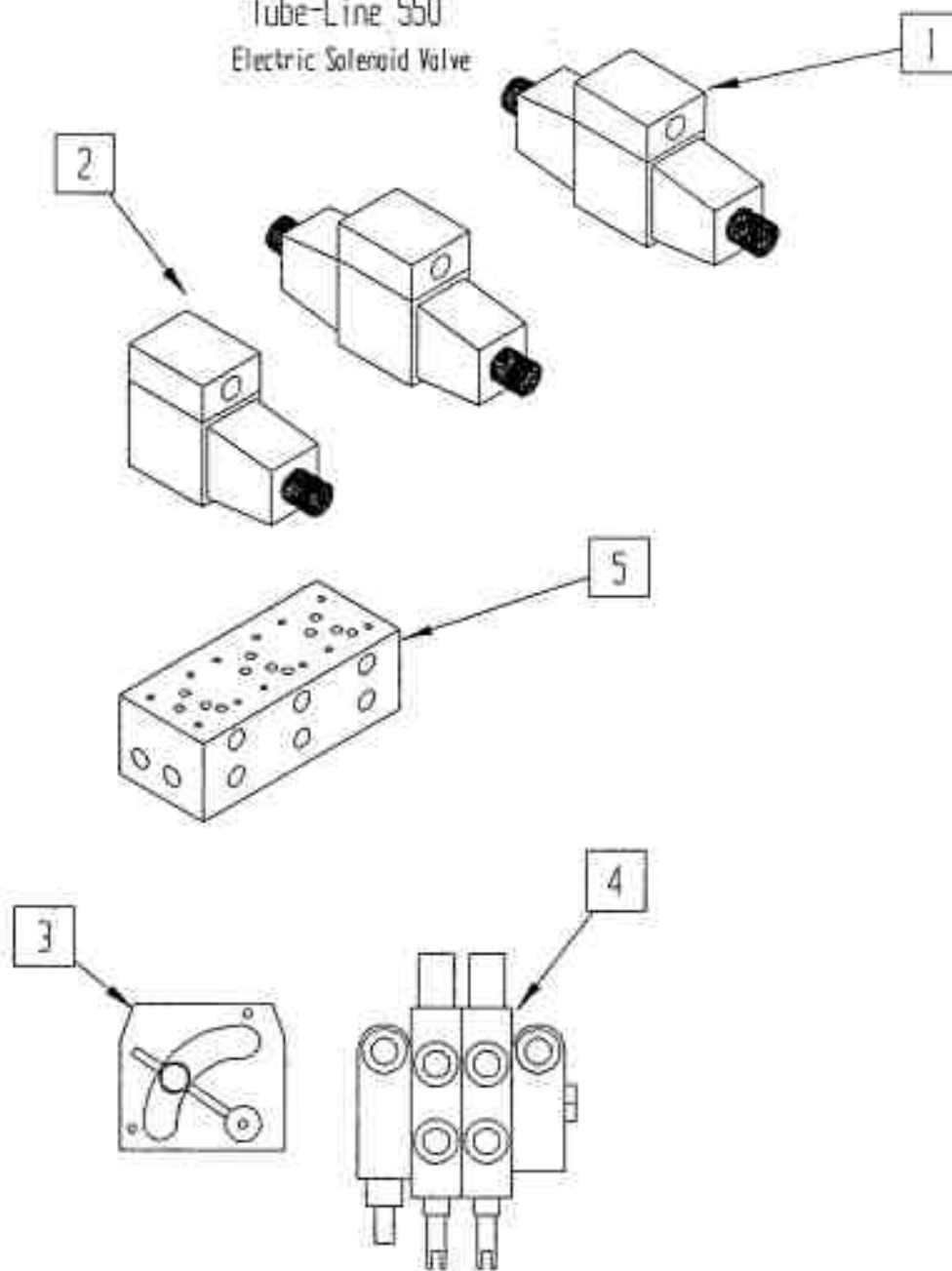

- | | |
|---|--|
| 1 | 2 pc VS12M3LGB75L tandem center 12 vdc |
| 2 | VS12M1AGB75L single sol 12 vdc |
| 3 | RD - 150 - 08 Flow control |
| 4 | 2 spool nonblock valve |
| 5 | Triple nonifold |

Tube-Line 550

Limit Switch

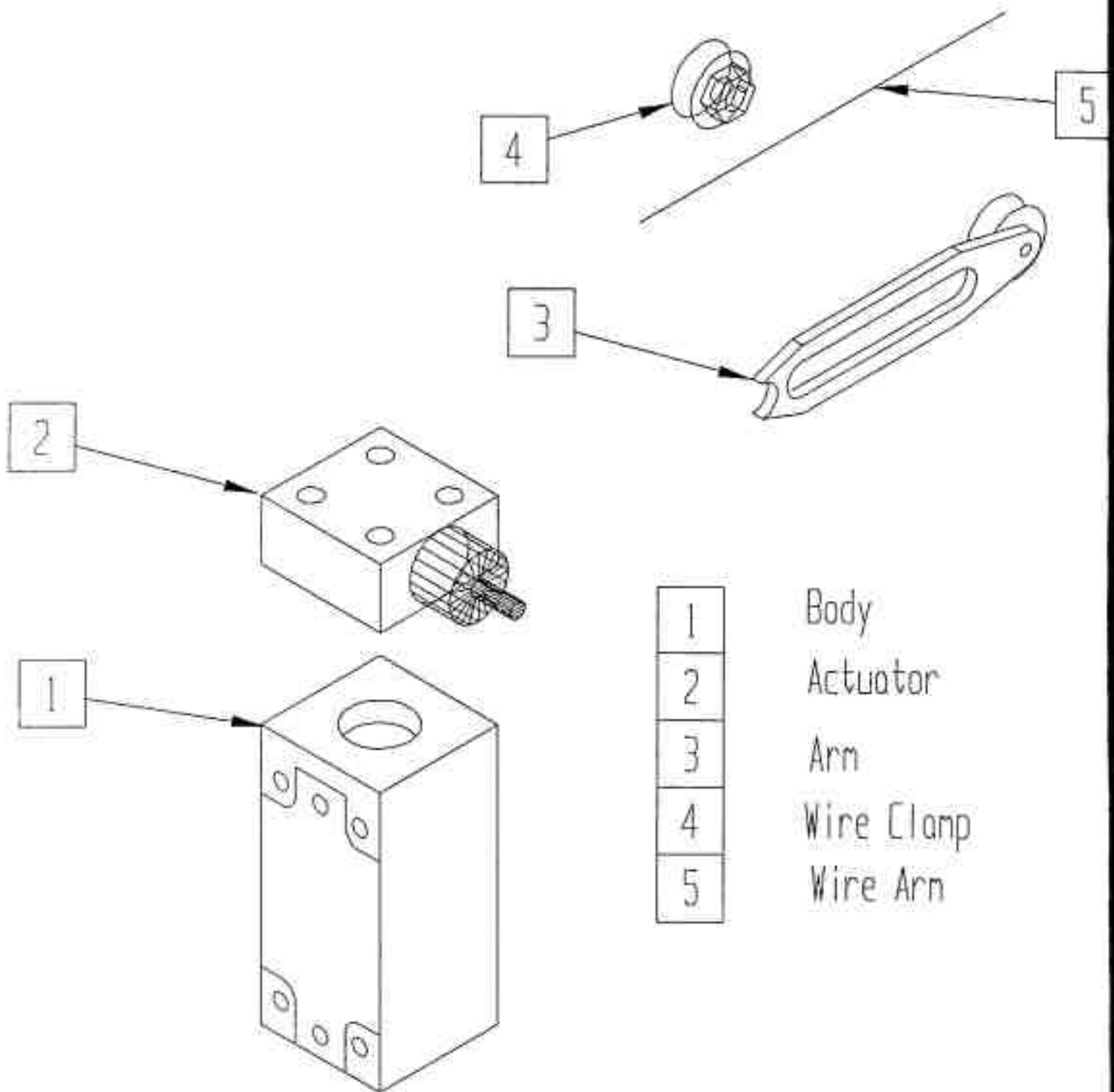

Tube-Line 599 Control Panel

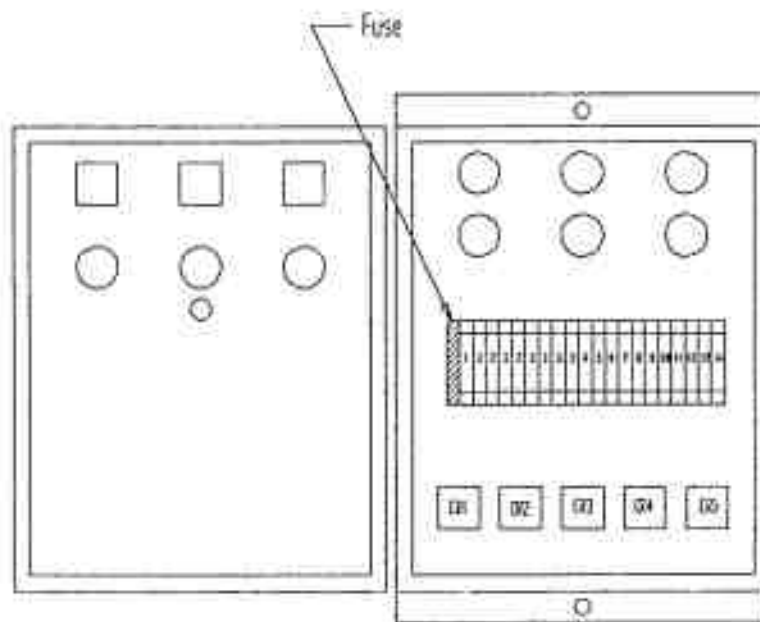
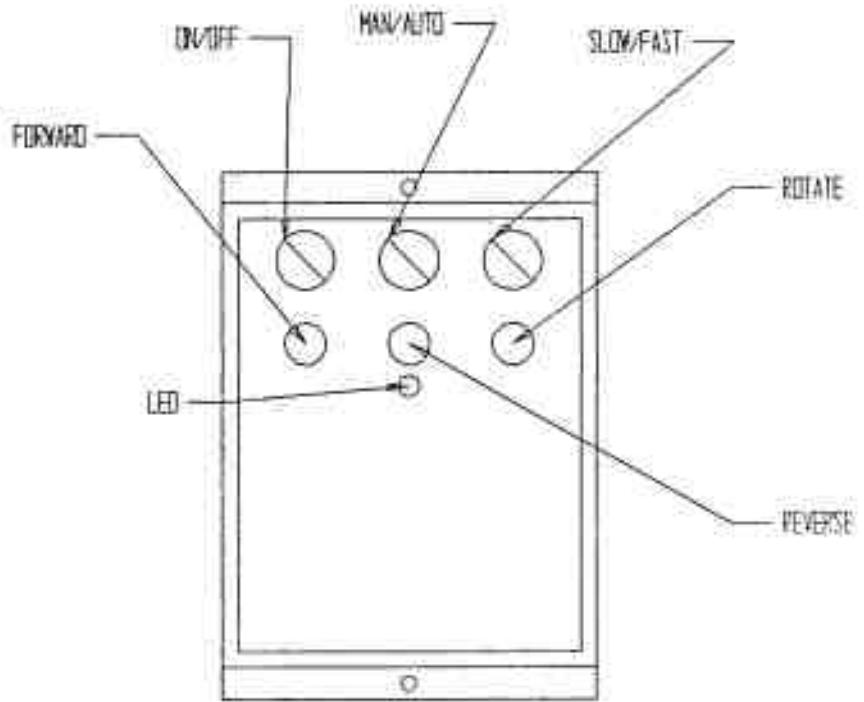

Tube-Line 550

Trigger & Battery hold down

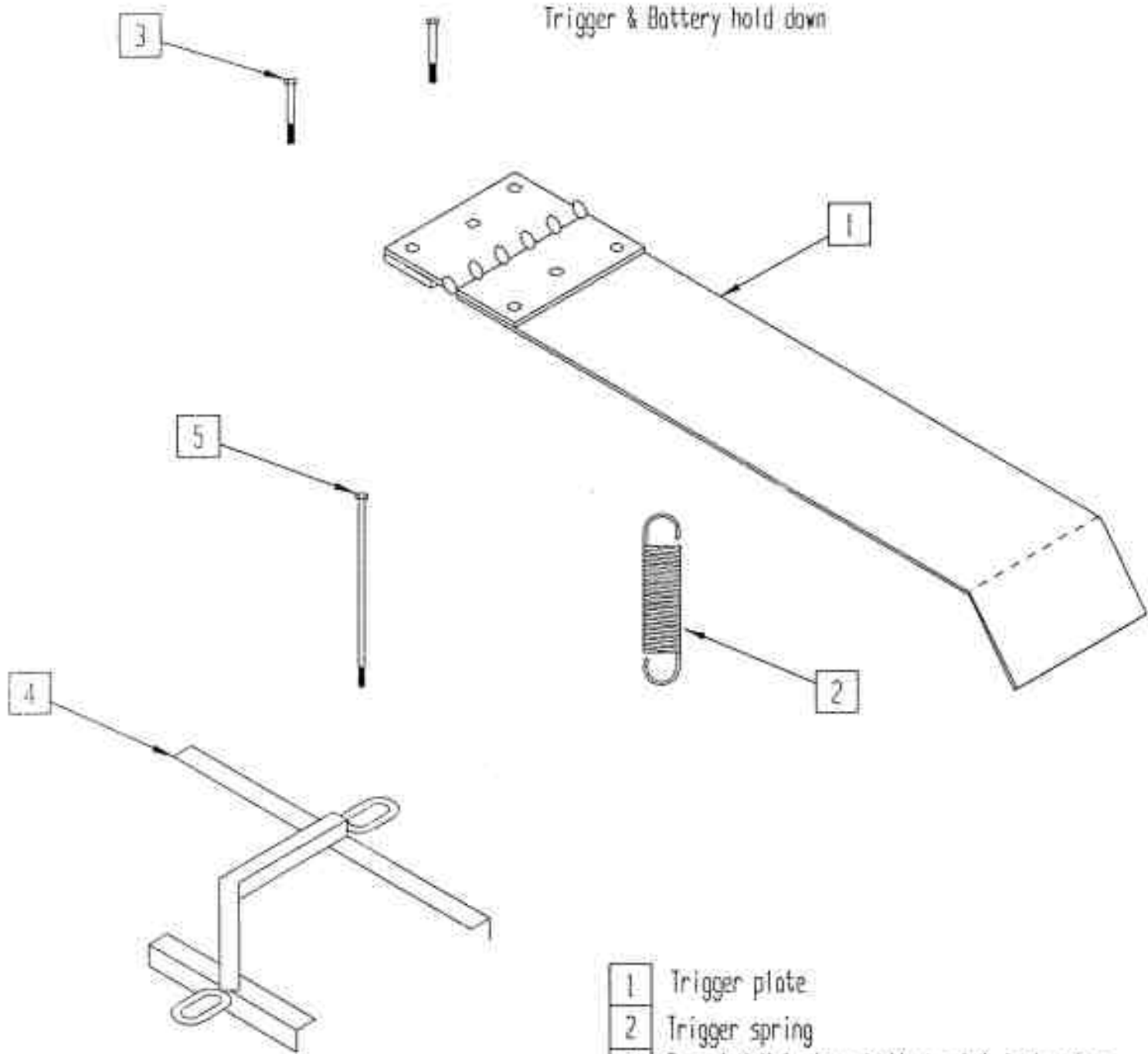

- | | |
|---|--|
| 1 | Trigger plate |
| 2 | Trigger spring |
| 3 | 2 pc 1/4 X 1 stove bolt / nut & lockwasher |
| 4 | Battery hold down |
| 5 | 2 pc 5/16 X 7 carriage bolt / nut / lockwasher |

TubeLine 599
Throttle Bracket

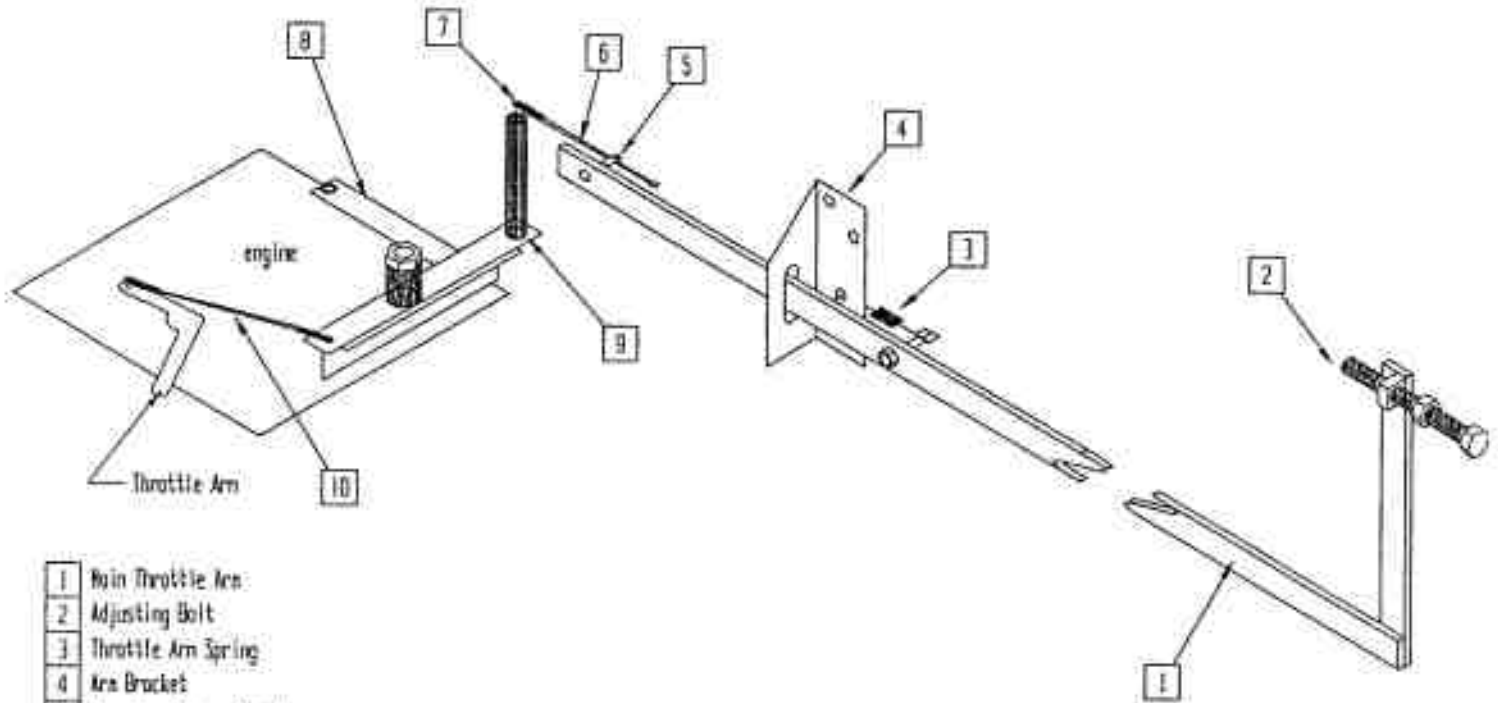

- | | |
|----|--------------------------|
| 1 | Main Throttle Arm |
| 2 | Adjusting Bolt |
| 3 | Throttle Arm Spring |
| 4 | Arm Bracket |
| 5 | Throttle Linkage Pivot |
| 6 | 1/4 x 5 INF Bolt |
| 7 | Throttle Ball Joint |
| 8 | Engine Bracket |
| 9 | Rocker Bar |
| 10 | 1/4 x 4 INF Threaded Rod |

Tube-Line 550

Manual Hydraulic Schematic

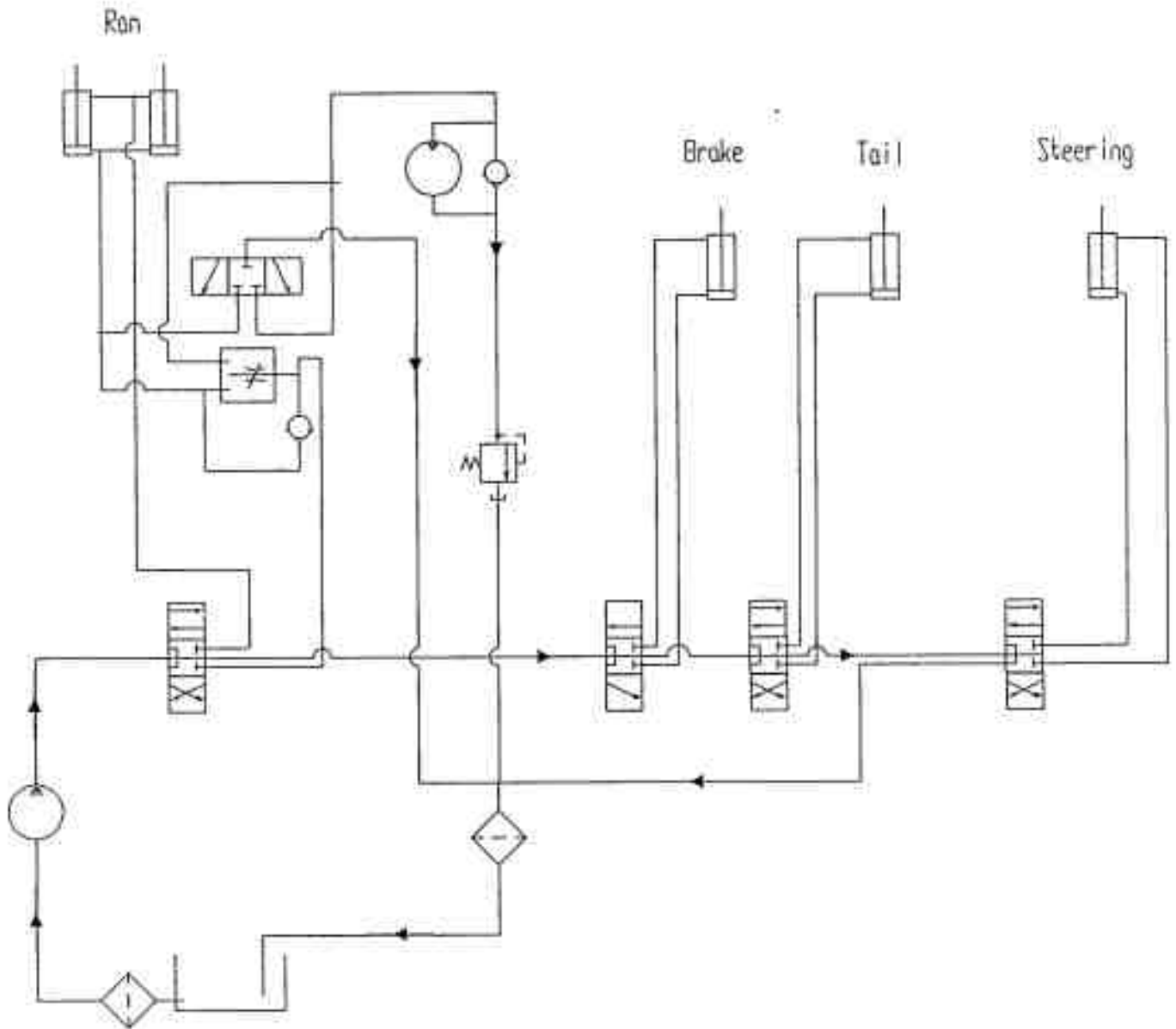

· TubeLine 550
Electric Hydraulic Schematic

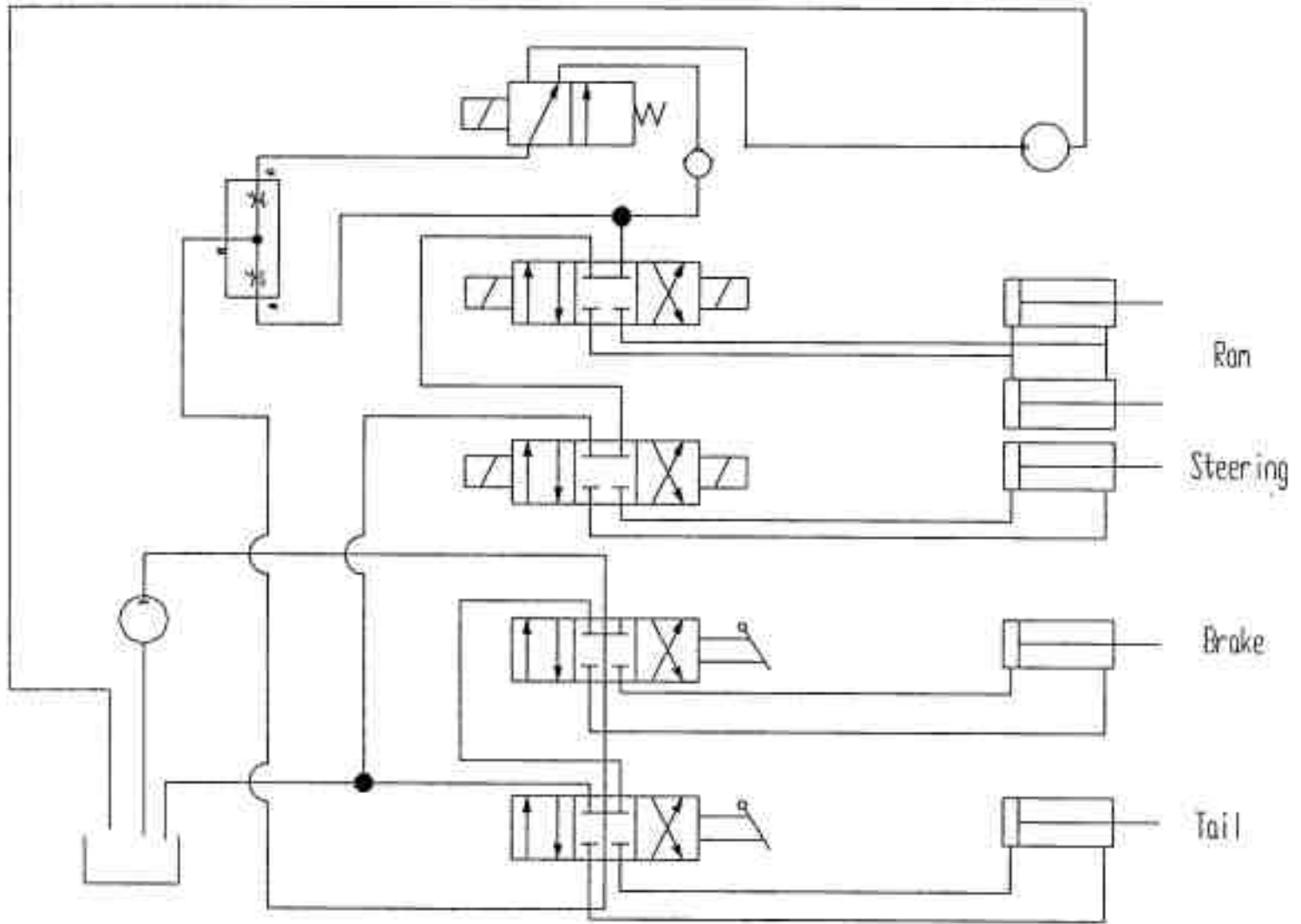

Tubeline 599 Electric Wiring Diagram

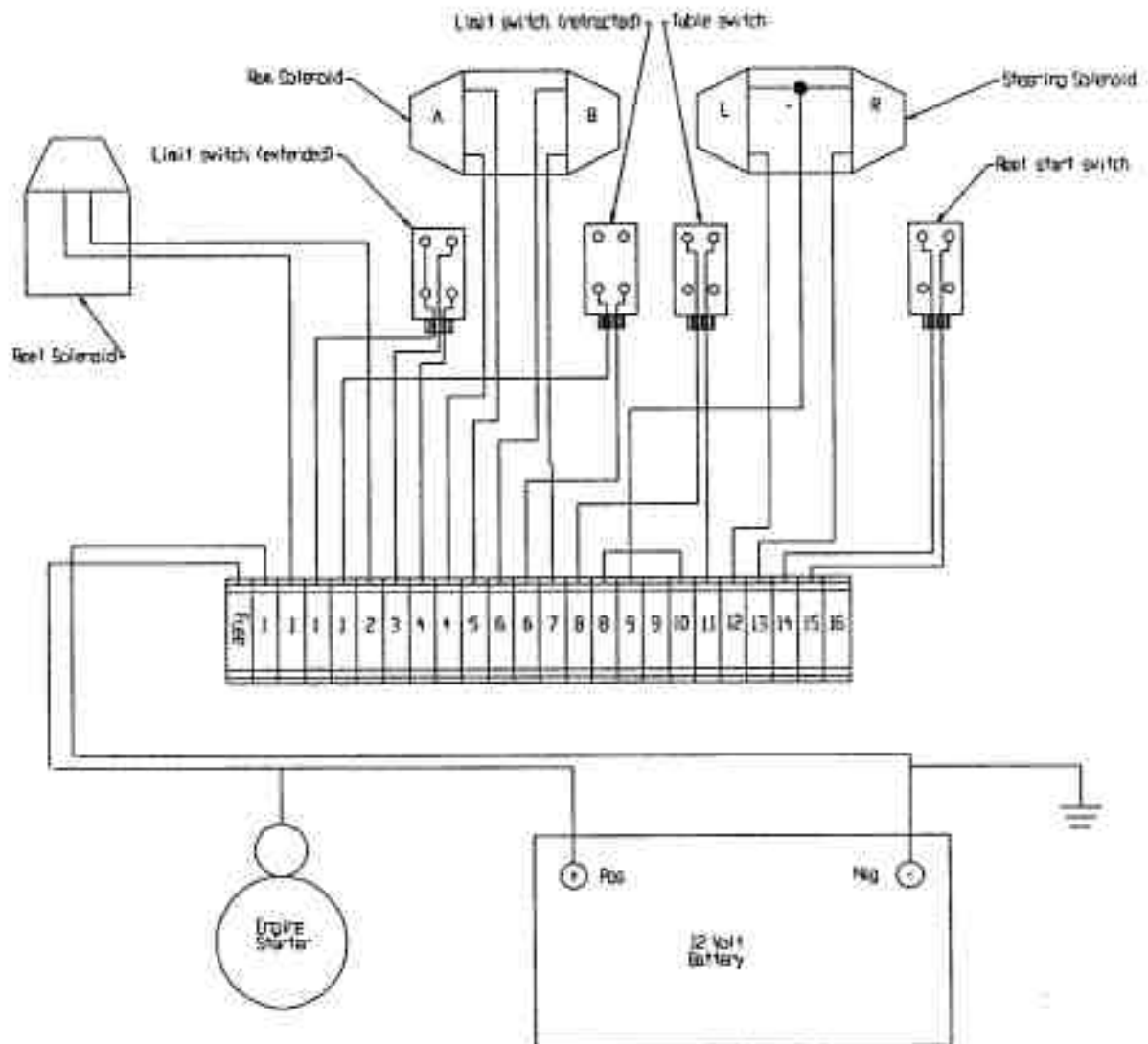

Tube-Line 589
Electric Control Panel Schematic

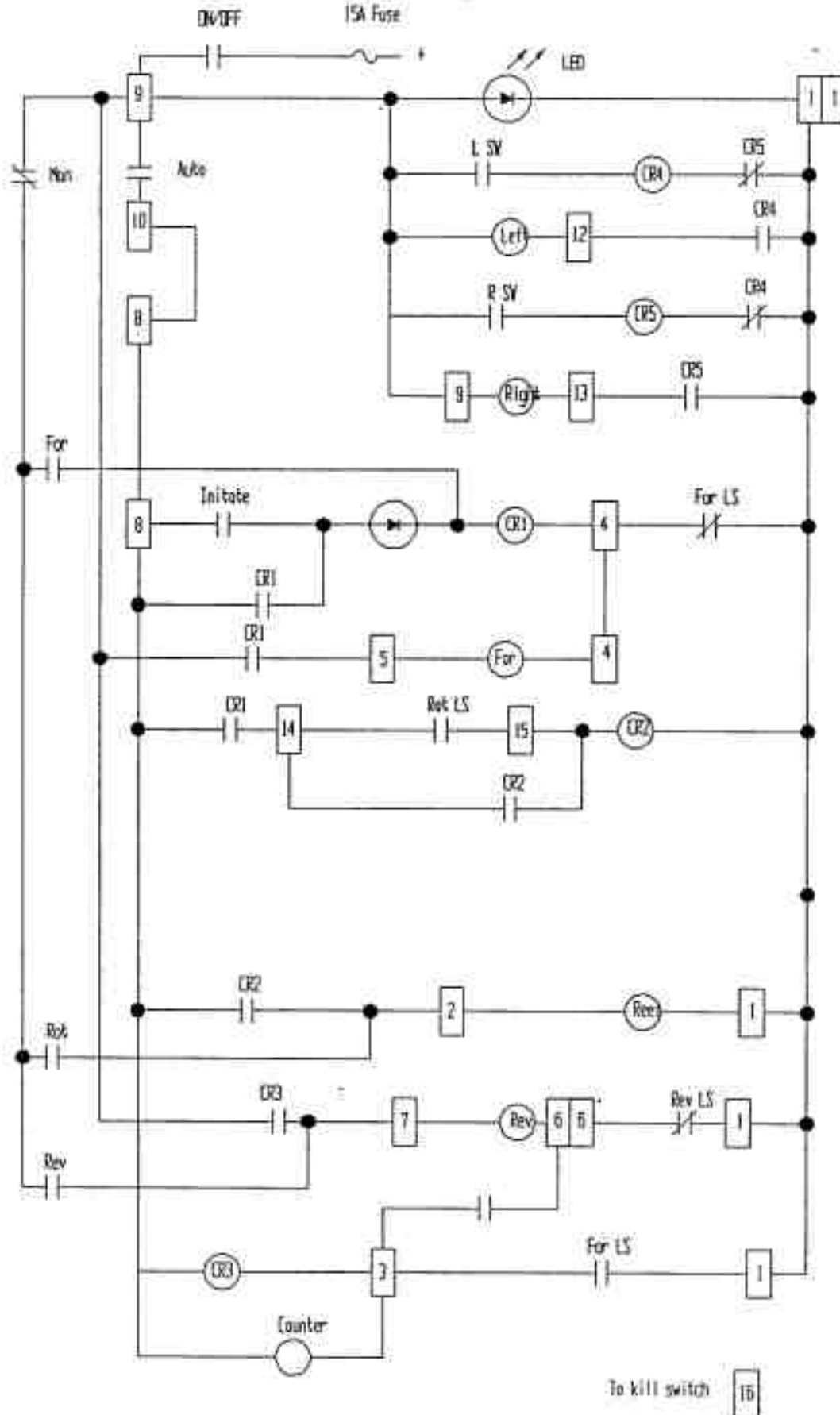

- Fuse block pos. -12 VDC
 #1 Neg 12VDC
 #1 reel solenoid
 #2 reel solenoid
 #1 Forward L/S Con.
 #3 Forward L/S NO
 #4 Forward L/S NC
 #4 Forward Solenoid
 #5 Forward solenoid
 #1 Reverse L/S NC
 #6 Reverse L/S NO
 #6 Reverse solenoid
 #7 Reverse solenoid
 #8 Film sensor L/S
 #10 Film sensor L/S
 #8 Start (trigger) L/S
 #11 Start (trigger) L/S
 #9 Steering Solenoid Con.
 #12 Steering solenoid Left
 #13 Steering solenoid Right
 #14 Rotation L/S NO
 #15 Rotation L/S
 #16 Kill switch

Tube-Line 5500

Manual Hydraulic Sequence of Operation

- 1 With valves in neutral position, engine running hydraulic fluid is pumped through valve stack and returned to reservoir.
- 2 Brakes, tail and steering are standard hydraulic cylinder operation.
- 3 Wrap cycle – push wrap valve in, detent will hold valve in position, fluid flows from valve through flowcontrol and is split into 2 circuits, one circuit will go to ram cylinders and the other will go to hydraulic motor. These circuits are proportioned with the lever on flowcontrol valve. With the selector valve handle in "Both" position flow will go to cylinder and motor. By changing flowcontrol handle, the cylinders will speed up or slow down accordingly. At the same time motor will change speed inversely to cylinder ie. when cylinder slows down motor will speed up.
- 4 Selector valve is used to bleed either cylinder or motor flow back to tank, or block both circuits causing both cylinder and motor to operate. ie. With handle in wrap only position the fluid that would normally go to the cylinder will flow back to tank. With handle in ram only position motor fluid will go to tank.
- 5 Wrap cycle – pull wrap valve out, detent will hold valve in position, fluid will flow from valve port causing cylinder to retract. Fluid from other end of cylinder will return through check valve, at flowcontrol back through valve stack and to tank.
- 6 Check valve at motor lets motor freewheel in one direction without cavitating. Relief valve at motor return acts as a restrictor valve to keep motor from turning when ram cylinder is retracting.

Tube-Line 5500

Electric Hydraulic

Sequence of operation

- 1 With valves in neutral position, control panel on/off switch in off position, engine running fluid is pumped through valve stack and returned to reservoir.
- 2 Brakes and tail are standard hydraulic cylinder operation.
- 3 Wrap cycle fluid flows from power beyond port on 2 spool valve to flowcontrol, and is split into 2 circuits one circuit goes to double solenoid valve for ram cylinder, the other circuit goes to single solenoid valve for hydraulic motor. By moving flowcontrol handle more or less fluid will flow to cylinder or motor ie. as more fluid flows to cylinder less fluid will flow to motor and vice-versa.
- 4 Electric control panel- "Man-Auto" switch turned to "Man". Turn "On/Off" switch to On, then red LED will light up indicating 12V power is at control circuits, with engine running. Push Forward button in to energize solenoid A on double solenoid valve. Ram cylinder will extend. Push Reverse button to energize solenoid B on same valve. Ram cylinder will retract. Push Rotate button in and hydraulic motor will turn. Push buttons have to be held in to operate, by releasing them action will stop. Engine throttle has linkage to slow engine down when ram is all the way to the front. Spring on linkage will speed engine up as soon as Ram cylinder starts to extend.
- 5 When "Man/Auto" switch is turned to Auto, Push-button switches no longer function. Depress trigger switch located on bale table, Ram hydraulic valve is energized. The ram cylinder will extend and engine will speed up. When ram extends to front slider switch, the switch will energize the single solenoid valve and turning the wrap motor. When ram is extended to the limit switch at the end of stroke, single solenoid valve and double solenoid valve A will turn off. Solenoid B will energize causing ram cylinder to retract until it trips limit switch at the front end of bale table, solenoid B will turn off, the ram cylinder will stop and engine will idle down.
- 6 Steering is done by steering switch, right/left activating steering double solenoid valve A or B. This valve will work in either manual or automatic mode.

TUBE-LINE 5500

PART NUMBERS

Page #	Ref #	Part #	Qty	Description
1	1	550-100-001	1	Hoop Outer Ring
1	2	550-100-002	1	Hoop Inner Ring
1	3	550-100-003	2	Mounting Bolt 1/2 x 2
1	4	550-100-076	2	1/2 Nut
1	5	550-100-075	2	1/2 Lockwasher
1	3	599-100-003	2	Mounting Bolt 5/8 x 3 1/2
1	4	599-100-004	2	5/8 Nut
1	5	599-100-005	2	5/8 Lockwasher
2	1	500-100-014	8	4" Wheel
2	2	500-100-015	8	Axle Bolt
2	3	500-100-016	16	Bearing Seal
2	4	500-100-017	8	Outer Race
2	5	500-100-018	8	Roller Bearing
2	6	500-100-019	8	Inner Race
2	7	500-100-020	8	Locknut
3	1	550-100-004	2	Main Wrap Bracket
3	2	550-100-005	4	1-14 UNF Castellated nut
3	3	550-100-006	4	Tensioner Roller
3	4	500-100-007	8	3/4 Flange Bearing
3	5	550-100-008	2	Small Gear
3	6	550-100-009	2	Large Gear
3	7	550-100-010	2	Gear Cover
3	8	550-100-011	2	Spool Holder
3	9	550-100-012	4	Wrap Spool
3	10	550-100-013	8	Washer
3	11	550-100-014	4	Locknut
3	12	550-100-015	4	Oilite Bushing
3	13	500-100-022	2	Plastic Pipe
3	14	500-100-021	4	Plastic Bearing
3	15	550-100-016	4	Bracket
3	16	550-100-017	4	Spacer
3	17	500-100-135	4	Spring
3	18	550-100-018	2	Axle Plastic Roller
3	19	550-100-003	2	1/2 x 2 Bolt c/w Locknut
3	20	550-100-019	16	5/16 Carriage Bolt
3	21	550-100-020	4	3/16 Keystock
3	22	550-100-021	2	Grease Fitting
3	23	599-100-006	4	10-24 x 3/4 Machine Bolt

4	1 599-100-100	1 Right Hoop Brace
4	2 599-100-101	1 Left Hoop Brace
4	3 599-100-102	1 Right Hoop Post
4	4 599-100-103	1 Left Hoop Post
4	5 599-100-104	2 Switch Adjuster Screw
4	6 599-100-105	1 Automatic Control Panel Mount
4	7 599-100-106	1 Manual Control Mount
5	1 599-100-022 R	1 Right Side Safety Door Bracket
5	1 599-100-023 L	1 Left Side Safety Door Bracket
5	2 599-100-024 R	1 Right Safety Door
5	2 599-100-025 L	1 Left Safety Door
5	3 500-100-041	2 Rubber Latch
5	4 500-100-040	2 Pin
5	5 500-100-042	2 Cotter Pin
5	6 500-100-119	6 3/8 x 1 1/4 Bolt
5	7 550-100-026	6 3/8 Locknut
5	8 550-100-027	2 Door Stay
6	1 500-100-049	1 Drive Wheel Base
6	2 500-100-050	1 Hydraulic Motor EATON Char-Lynn 101-1004
6	3 500-100-051	1 Motor Hub
6	4 500-100-052	1 Drive Wheel
6	5 500-100-053	4 1/2 x 3 UNF Bolt
6	6 500-100-054	4 1/2 Wheel Nut
6	7 500-100-055	2 5/8 x 1 1/2 Bolt
6	8 500-100-056	2 5/8 Locknut
6	9 500-100-057	4 3/8 x 3/4 Bolt
6	10 500-100-038	4 3/8 Lockwasher
6	11 500-100-059	1 Check Valve (manual model only)
6	12 500-100-060	1 Washer
6	13 500-100-061	1 1/4 x 1 Bolt & Lockwasher
6	14 500-101-222	1 Relief Valve (manual model only)
6	15 500-101-231	1 Wheel Tensioner Spring
6	16 500-101-232	1 Spring Tensioner Bolt
7	1 500-100-063	2 Inner Seal
7	2 500-100-064	2 Inner Bearing
7	3 500-100-065	2 Inner Bearing Race
7	4 500-100-066	2 Hub
7	5 500-100-067	2 Outer Bearing Race
7	6 500-100-068	2 Outer Bearing
7	7 500-100-069	2 Flatwasher
7	8 500-100-070	2 Castellated Nut
7	9 500-100-071	2 Cotter Pin
7	10 500-100-072	10 Wheel Stud
7	11 500-100-073	2 Dust Cap

